

UNIVERSITY OF EDUCATION, WINNEBA

**EFFECTS OF THE TEACHING MODEL FOR HOT CONCEPTUAL CHANGE
ON THE ACADEMIC PERFORMANCE OF STUDENTS IN THE CONCEPT
CURRENT ELECTRICITY**



MASTER OF PHILOSOPHY

2023

UNIVERSITY OF EDUCATION, WINNEBA

**EFFECTS OF THE TEACHING MODEL FOR HOT CONCEPTUAL CHANGE
ON THE ACADEMIC PERFORMANCE OF STUDENTS IN THE CONCEPT
CURRENT ELECTRICITY**

SAMUEL AIDOO

(202113580)

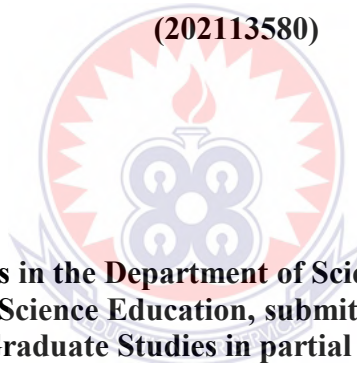

**A thesis in the Department of Science Education,
Faculty of Science Education, submitted to the School of
Graduate Studies in partial fulfilment**

**of the requirements for the award of the degree of
Master of Philosophy
(Science Education)
in the University of Education, Winneba**

SEPTEMBER, 2023

DECLARATION

Student's Declaration

I, SAMUEL AIDOO, declare that this thesis, with the exception of quotations and references contained in published works which have all been identified and acknowledged, is entirely my own original work, and that it has not been submitted, either in part or whole, for another degree elsewhere or in this University.

SIGNATURE:

DATE:



Supervisors' Declaration

I hereby declare that the preparation and presentation of this work was supervised in accordance with the guidelines for supervision of thesis as laid down by the University of Education, Winneba.

NAME OF SUPERVISOR: PROFESSOR MAWUADEM KOKU AMEDEKER

SIGNATURE:

DATE:

DEDICATION

I dedicate this work to my wife, Jennifer Dawuso, my children Nana Kofi Aidoo and Abena Ewuraduwa Aidoo, and my lovely parents Mr. and Mrs. Aidoo.



ACKNOWLEDGEMENTS

I want to express my gratitude to my supervisor, Prof. Mawuadem Koku Amedeker for his meticulous scrutiny, valuable comments and insightful suggestions, given me throughout the period of working with him. I deeply appreciate Mrs. Adeline B. Kallon's assistance, inspiration, and insightful discussions that helped shape the thesis.

I am extremely thankful to my MPhil colleagues, especially Iddrisu Mohammed for his timely advice, suggestions and motivation that kept me going in challenging times. Finally, and most significantly, I offer God the glory and honour due Him for guiding me through this study.



TABLE OF CONTENTS

Content	Page
DECLARATION	iii
DEDICATION	iv
ACKNOWLEDGEMENTS	v
TABLE OF CONTENTS	vi
LIST OF TABLES	x
LIST OF FIGURES	xi
ABSTRACT	xii
CHAPTER ONE: INTRODUCTION	1
1.0 Overview	1
1.1. Background of the Study	1
1.2 Statement of the Problem	2
1.3 Purpose of the Study	3
1.4 Objectives of the Study	3
1.5 Research Questions	4
1.6 Significance of the Study	4
1.7 Delimitations	5
1.8 Limitations	6
CHAPTER TWO: LITERATURE REVIEW	7
2.0 Overview	7
2.1 Conceptual Change Models	7
2.2 Constructivism	18
2.2.1 Psychological constructivism	18

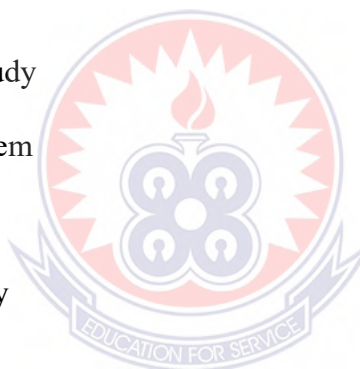

2.2.2 Social constructivism	19
2.2.3 The constructivist view of the role of the learner	21
2.2.4 The constructivist view of the role of the instructor	22
2.3 Conceptual Change and Conceptual Change Approach to Teaching	22
2.4 Relevance of the Conceptual Change Approach to Teaching	24
2.5 Performance of Students in Physics	24
2.6 Studies on Students' Misconception about Electricity	26
2.6 Conceptual framework	30
2.7 Chapter Summary	34
CHAPTER THREE: METHODOLOGY	36
3.0 Overview	36
3.1 Research Design	36
3.1.1 Action Research Design	36
3.2 Population	39
3.3 Sample and Sampling Procedure	40
3.4 Research Instruments	40
3.5 Validity and Reliability of Research Instruments	42
3.6 Data Collection Procedure	43
3.6.1 Report on teaching intervention using TMHCC	44
3.6.1.1 Report on teaching intervention Lesson 1	44
3.6.1.2 Report on teaching intervention Lesson 2	46
3.6.1.3 Report on teaching intervention Lesson 3	48
3.6.1.4 Report on teaching intervention Lesson 4	50



3.6.1.5 Report on teaching intervention Lesson 5	52
3.6.1.6 Report on teaching intervention Lesson 6	54
3.7 Data analysis	56
3.8 Ethical Consideration	57
3.9 Summary	58
CHAPTER FOUR: RESULTS AND DISCUSSION	59
4.0 Overview	59
4.1 Analysis of Data from the Three Research Instruments	59
4.1.1 Analysis with respect to research question one	59
4.1.1.1 Presentation of test data	59
4.1.1.2 Presentation of semi-structured interview data	68
4.1.1.3 Presentation of field notes data	69
4.1.2. Analysis with Respect to Research Question Two	71
4.1.2.1 Presentation of test data	71
4.1.2.2 Presentation of semi-structured interview data	85
4.1.3 Analysis with Respect to Research Question Three	87
4.1.3.1 Presentation of test data	87
4.1.3.2 Presentation of semi-structured interview data	88
4.1.3.3 Presentation of fieldnotes data	90
4.2 Summary	92
CHAPTER FIVE: SUMMARY, CONCLUSION AND RECOMMENDATIONS	93
5.0 Overview	93
5.1 Summary of Findings	93

5.2 Conclusion	94
5.3 Recommendations	95
5.4 Suggestions for Further Research	96
REFERENCES	97
Appendix A: Electricity Concepts Test (ECT) for Lesson 1	104
Appendix B Electricity Concepts Test (ECT) for Lesson 2	106
Appendix C: Electricity Concepts Test (ECT) for Lesson 3	107
Appendix D: Electricity Concepts Test (ECT) for Lesson 4	108
Appendix E: Electricity Concepts Test (ECT) for Lesson 5	109
Appendix F: Electricity Concepts Test (Ect) for Lesson 6	111
Appendix G: Students Activity Sheet	113
Appendix H: Semi-Structured Face-to-Face Guide	127
Appendix I: Rubrics For Electricity Concepts Test (ECT) for Lesson 1:	
Appendix J: Rubrics Electricity Concepts Test (ECT) for Lesson 2	129
Appendix K: Electricity Concepts Test (ECT) for Lesson 3	142
Appendix L: Rubrics Electricity Concepts Test (ECT) for Lesson 4	147
Appendix M: Rubrics For Electricity Concepts Test (ECT) for Lesson 5	152
Appendix N: Rubrics For Electricity Concepts Test (ECT) for Lesson 6	158

LIST OF TABLES

Table	Page
1: Data Analysis plan	57
2: Results of Wilcoxon Signed Rank Test and Effect Size for the Pretest and Posttest in Lesson 1	60
3: Results of Wilcoxon Signed Rank Test and Effect Size for the Pretest and Posttest in Lesson 2	61
4: Results of Wilcoxon Signed Rank Test and Effect Size for the Pretest and Posttest in Lesson 3	63
5: Results of Wilcoxon Signed Rank Test and Effect Size for the Pretest and Posttest in Lesson 4	64
6: Results of Wilcoxon Signed Rank Test and Effect Size for the Pretest and Posttest in Lesson 5	65
7: Results of Wilcoxon Signed Rank Test and Effect Size for the Pretest and Posttest in Lesson	67
8: Performance of students in Electrical Current	72
9: Performance in Electromotive force and Potential difference	75
10: Performance in Electrical Resistance	77
11: Performance in Ohm's law concept	79
12: Performance in Series Connection of Electrical Components	81
13: Performance in Parallel Connection of Electrical Components	83

LIST OF FIGURES

Figure	Page
1: Cognitive Affective Model of Conceptual Change.	15
2: Adapted Conceptual Framework for Implementing the Teaching Model for Hot Conceptual Change (TMHCC) to improve students' conceptions	32
3: Cyclical procedure for Action Research according to Cohen et al. (2018)	37
4: Data Collection Procedure	44
5: Rate of occurrence of students' misconceptions before and after the intervention with the TMHCC	88



ABSTRACT

The conceptual change models have been continually developed over the years and are used to improve students' conceptual understanding through the remedying of students' misconceptions. Among these models, the Teaching Model for Hot Conceptual Change (TMHCC) propounded by Kural and Kocakulah was used as a teaching intervention to improve students' academic performance in some selected topics in direct current electricity. This conceptual change model lends itself to the identification and remedying of students' misconceptions through the active engagement of students' metacognition, creation of cognitive conflict, and utilisation of motivational constructs. An action research design was adopted in this study to gather data. One intact Form Two class with a class size of 40 in a public school in Effutu Municipality was used for the study. The research instrument used were the Electricity concept test, focused group interview and field observation. The Wilcoxon signed rank test, effect size, frequencies and percentages were used in analysing the data. The results of the study showed that the TMHCC positively affect students conceptual understanding of current electricity through improved students' critical thinking, critique, collaboration, communication, circuit connection, measurement skills, and positive attitudes towards learning physics as evidenced by punctuality, attentiveness, and enthusiasm. It was evident that TMHCC significantly impacts students' academic performance. Consequently, it was recommended among others that teachers should place more importance on teaching effectively such concepts in electricity so that students are able to grasp and overcome their inability to understand them. Students must be provided with some more opportunities for making them understand it.

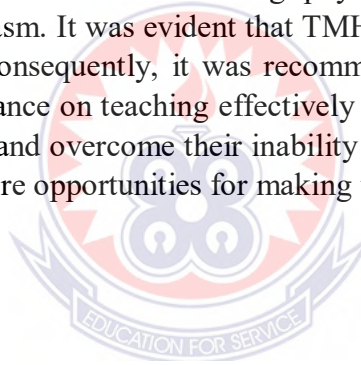

CHAPTER ONE

INTRODUCTION

1.0 Overview

This chapter discusses the background to the study, statement of the problem, purpose of the study, research objectives and questions, significance of the study, delimitations, and limitations of the thesis.

1.1. Background of the Study

Students come to class with a variety of preconceptions which develop through their everyday experiences before being exposed to formal instruction, (Baser, 2006). Therefore, students' preconceptions play a crucial role in teaching and learning science (Duit & Treagust, 2003). When students' preconception contradicts the new experience they are being presented with, an obstacle in the learning process is created. The student's preconception in this case is known as a misconception. Students interpret the new experience through their erroneous understandings, thereby interfering with their ability to correctly grasp the new knowledge. Over the years, physics students' performance in Ghana has typically and regularly been poor (Anamuah-Mensah, 2007). Misconceptions among students have been identified as a significant contributor to the poor performance in physics (Assem, Nartey, Appiah, & Aidoo, 2023). In most cases, students are not even aware that the knowledge they have is erroneous and inconsistent with scientific views. Students' misconceptions are entrenched so much in their thinking and tend to make students very resistant to instruction. In order to reduce students' misconceptions and promote meaningful learning, they must undergo a conceptual change. Teachers need to direct their instruction in a way that brings about this conceptual change in the students (Duit & Treagust, 2003). The implementation of the conceptual change approach to teaching results in deeper conceptual understanding

which leads to meaningful learning, instils confidence in the students, and ultimately results in higher academic performance (Asgari, Ahmadi, & Ahmadi, 2018).

The conceptual change approach to teaching encompasses the utilisation of a conceptual change model as a pedagogical framework. Its central aim is to adeptly identify and rectify students' misconceptions, thereby nurturing a comprehensive understanding and assimilation of scientific concepts. This method is characterised by active student involvement, ongoing assessment, reflective practices, and motivational feedback mechanisms (Phromsena, Promratana, & Panchompoo, 2019). One such model that exemplifies this approach is the Kural and Kocakulah (2016) Model for Hot Conceptual Change. This model addresses students' cognitive and affective dimensions while incorporating metacognition and motivational feedbacks which are pivotal aspects influencing the conceptual change process (Kural & Kocakulah, 2016).

The desire to remedy misconceptions among students and improve students' performance in physics was what prompted the study. The study was designed to implement the teaching model for hot conceptual change propounded by Kural and Kocakulah (2016) to teach some selected topics in current electricity in Winneba Secondary School to remedy students' misconceptions and improve performance in physics.

1.2 Statement of the Problem

Misconceptions in current electricity among Form Two Agric1 students studying physics at Winneba Secondary School impede their comprehension and application of this new concept, resulting in subpar performance in the subject (Chi, 2005). These misconceptions not only undermine students' confidence and motivation in learning physics but also lead to disengagement and frustration (Adams & Wieman, 2011;

Meltzer & Thornton, 2012), exacerbating their academic challenges. If students' misconceptions are not addressed at the right time, they appear in the students' conceptual framework even in subsequent educational levels (Baser, 2006). Therefore, there is the need to implement the conceptual change approach to teaching which has been proven to be a strategy that is particularly effective in remedying students' misconceptions, resulting in deeper conceptual understanding and ultimately higher academic performance (Kural & Kocakulah, 2016; Phromsena et al., 2019; Davis, 2001). Hence, this study utilised the Teaching Model for Hot Conceptual Change, a conceptual change model, as a teaching strategy to instruct Form 2 students on selected topics in current electricity at Winneba Secondary School in the Effutu Municipality, aiming to remedy their misconceptions and enhance their academic performance.

1.3 Purpose of the Study

The study was designed to determine the effects of implementing the Teaching Model for Hot Conceptual change on students' academic performance in some selected topics in current electricity.

1.4 Objectives of the Study

The following objectives were formulated to guide the study:

- i. To determine the effect of the Teaching Model for Hot Conceptual change on students' conceptual understanding of selected topics in current electricity.
- ii. To determine the performance of students in the selected topics in current electricity using the Teaching Model for Hot Conceptual change.
- iii. To determine the conceptual changes that occurred during the use of the Teaching Model for Hot Conceptual change.

1.5 Research Questions

In pursuance of the research objectives, the following research questions were formulated to guide the study:

- i. What is the effect of the Teaching Model for Hot Conceptual change on students' conceptual understanding of selected topics in current electricity?
- ii. What is the performance of students in the selected topics in current electricity taught using the Teaching Model for Hot Conceptual change?
- iii. What conceptual changes occurred during the use of the Teaching Model for Hot Conceptual change in teaching the selected topics in current electricity?

1.6 Significance of the Study

Firstly, the study would help colleague teachers to be well informed about what is expected of them when they want to implement the conceptual change approach to teaching, specifically the teaching model for hot conceptual change in a lesson. This in turn would deepen the understanding of teachers on the conceptual change approach to teaching thereby increasing their confidence and the rate of usage in class.

Embracing a conceptual change approach aligns with contemporary educational paradigms that prioritise critical thinking, problem-solving, and lifelong learning skills. The findings from this study would not only enriches classroom instruction but also cultivates a culture of inquiry and intellectual curiosity among students, equipping them with the necessary tools to navigate an ever-evolving world.

Finally, the findings of this study could form the basis for the organisation of workshops, seminars, and in-service training for teachers to be trained on how to use the conceptual change approach teaching strategies like the teaching model for hot conceptual change effectively in class to improve students learning.

1.7 Delimitations

There are several conceptual change models a physics teacher could use when implementing the conceptual change approach to teaching. For this study, the Teaching Model for Hot Conceptual Change was used as a teaching strategy by the researcher to improve students' conceptions of physics thereby resulting in higher academic performance in physics. The teaching model for hot conceptual change was chosen because it is recent and to the best of the knowledge of the researcher, has not been tested in the context of Ghana.

The study was conducted using a single Form Two science class in Winneba Secondary School in the Effutu Municipality. The Form two class was taught by a teacher who happens to be the researcher. The Form three classes were not chosen because the students were busily preparing for their West Africa Senior School Certificate Examination and they had a lot to do within a limited time. Form one class was also not chosen because they were recently enlisted into the school and therefore did not possess the characteristics the researcher was interested in. On the other hand, the Form 2 class was chosen because it was a class the researcher taught and hence the implementation of the conceptual change approach to teaching could be done with ease.

Given the inherent time demands of the conceptual change approach, implementing it effectively across a broader cohort of teachers would necessitate extensive training and ongoing assessment. Thus, the researcher undertook the implementation of the Teaching Model for Hot Conceptual Change independently. This decision was made to ensure a focused and thorough execution of the approach, allowing for a comprehensive examination of its efficacy without the added complexity of coordinating multiple educators. By singularly executing the implementation, the researcher could closely

monitor and evaluate the outcomes, providing valuable insights into the practical application of the conceptual change approach in the educational context under study.

The study focused on only some selected concepts in current electricity. The current electricity was chosen because it was a topic students had challenges understanding it due to the many misconceptions they held (Senar & Erylimaz, 2004; Küçüközer, & Kocakulah, 2007; Aboagye, 2009;). Furthermore, current electricity was the topic to be covered according to the scheme of work of the researcher (a teacher in Winneba Secondary School) for the semester. The study narrowed its focus to specific concepts within the expansive domain of electricity, recognising the impracticality of comprehensively covering all its facets within a single study. Specifically, it delved into fundamental concepts such as electric current, voltage, electromotive force, and electric resistance, exploring their interrelationships. Additionally, the study examined the parallel and series connections of resistors (bulbs) to provide a more targeted investigation into the application and understanding of these concepts. By strategically selecting these key components, the study aimed to provide a thorough examination of foundational principles while acknowledging the breadth of the broader topic of electricity.

1.8 Limitations

The study could not control extraneous variables such as age, ability, maturation, experience and previous learning which may influence students' understanding of the concepts and so might lack internal validity.

CHAPTER TWO

LITERATURE REVIEW

2.0 Overview

This section reviews existing literature on the topic and highlights the theories that underpin this study. The objective was to explore what major authors and writers have written on the topic.

2.1 Conceptual Change Models

In an attempt to correct students' misconceptions, several scholars have proposed conceptual change theories or models that could rectify students' misconceptions and promote meaningful learning (Alsop & Watts, 2000; Kural & Kocakulah, 2016). These conceptual change theories were developed taking on at least one of the following perspectives: epistemological, ontological and affective (Duit & Treagust, 2003). According to Treagust and Duit (2008), conceptual change viewed as epistemology is when the researcher examines students' learning of science concepts exhibited by different representations of knowledge. They also added that conceptual change viewed as ontology has to do with how students view the nature of the concept being investigated, or how students considered scientific conceptions in terms of their views of reality. An affective perspective of conceptual change takes into account students' interests and motivation.

Kural and Kocakulah (2016) outline the conceptual change theories/models found in literature as Posner et al.'s (1982) conceptual change theory, Chi et al.'s (1994) theory of conceptual change, Tyson et al.'s (1997) three dimensional model of conceptual change, Alsop & Watts's (1997) four-dimensional model of conceptual change, Yıldız's (2008) metacognition based four-dimensional conceptual change model, Dole and

Sinatra's (1998) cognitive reconstruction of knowledge model (CRKM), and Gregoire's (2003) cognitive-affective model of conceptual change (CAMCC). According to Phromsena et al. (2019), Kural and Kocakulah's Teaching Model for Hot Conceptual Change (TMHCC) is a recent Conceptual change model.

According to Duit, Treagust, and Widodo (2013), the earliest model of conceptual change termed the classical conceptual change model was postulated by Posner, Strike, Hewson, and Gertzog in 1982. The classical conceptual change model was modelled from the epistemological perspective (Duit et al., 2013) and paralleled Kuhn's scientific revolution theory and Piaget's notions of assimilation and accommodation (Özdemir, & Clark, 2007). Posner et al. (1982) posit that scientists might occasionally fail to describe new facts with their current viewpoints, according to Kuhn's Theory of Scientific revolution. The authors called this stage a crisis. In such circumstances, scientists tend to look for new paradigms that can explain the new facts. They further added that when a new paradigm is able to explain a new reality, scientists begin to use it instead of the old one. Conceptual change theory devised by Posner et al. (1982) used a crisis and transition continuum from an existing or old paradigm to a new paradigm. To explain learning, Posner and colleagues employed Piaget's concept of assimilation and accommodation (Duit et al., 2013). Kural and Kocakulah (2016) assert that assimilation is characterised as a student's inclination to explain new concepts using preconceptions when they encounter new phenomena. They argue that preconceptions can prevent students from successfully explaining new phenomena. When students realise that their preconceptions are unable to solve the problem, they become dissatisfied as a result of the anomaly. Students are compelled to alter or rearrange their preconceived notions. Posner et al. (1982) called this stage is called accommodation in conceptual change theory. In furtherance, Posner et al. (1982) highlighted that if the existing conception

was found unsuccessful, it would more likely be rejected. If the new concept has the potential to solve the problem, it will be more likely to be accepted.

According to Posner et al. (1982), dissatisfaction, intelligibility, plausibility, and fruitfulness are the conditions necessary for a conceptual change. The researchers contend that students must first recognise that there are some flaws in their reasoning and that their approach does not address the problem. They added that students will accommodate a new conception if they find it intelligible. The concept should not only make sense, but the students should also be able to regurgitate the argument and ideally be able to explain that concept to other classmates. Furthermore, the new conception must be plausible for it to be accommodated. The new concept must make more sense than the old concept and must have the capacity to solve the problem. The students should be able to decide on their own how this new concept fits into their ways of thinking and recall incidences where this concept could be applied. For the new conception to be accommodated, the learners need to find it fruitful in the sense that this concept should have the potential to be extended to other incidences, and open up new areas of inquiry. In other words, the new concept should do more than merely solve the problem at hand and open up new areas of inquiry.

Kural and Kocakulah (2016) elucidated that the conceptual change model propounded by Posner and colleagues explains conceptual change with dissatisfaction and new concepts' features like comprehensibility, plausibility, and fruitfulness. If the new concepts are not perceived as intelligible, plausible, and fruitful, preconceptions of students will persist and conceptual change does not occur. They also added that all the conditions help students to solve challenges and correctly transfer knowledge across multiple contexts.

According to Posner et al. (1982), a teacher who uses the classical conceptual change theory to teach is required to elicit students' preconceptions by using questioning or pre-test. The teacher is required to present materials (like educational videos) to the students that will make them dissatisfied with their conception. The teacher must facilitate the exchange of views and challenge students to compare ideas, including the evidence from the scientific perspective. Opportunities for students to use the new ideas (scientific conceptions) in familiar settings should be provided for students.

According to Kural and Kocakulah (2016), Chi, Slotta, and de Leeuw(1994) propounded a conceptual change theory that elucidates how ontological perspectives on conceptions in student minds influence conceptual change. Chi, Slotta, and de Leeuw (1994, as cited in Kural & Kocakulah, 2016) believe that students' conceptions change as they move from one category to the next and that students have ontological categories that deal with the universe's assets and objects. According to Kural and Kocakulah (2016), Chi and colleagues believed that matter, processes, and mental states are the three ontological categories. Matter refers to how you classify your assets and objects, such as alive or dead, heavy or light, solid or liquid. The process category includes phenomena and relationships. The researchers further assert that preconceptions denote the category of substance, whereas scientific conceptions denote the category of processes. The conceptual change is simple if these two notions are ontologically compatible. However, if both are ontologically incompatible, conceptual change is a difficult process. The ontological category of concept remained the same during the assimilation phase but changed during the accommodation phase.

A three-dimensional conceptual change model was formulated by Tyson, Venville, Harrison, and Treagust in 1997 (Kural & Kocakulah, 2016). According to Tyson et.al

(1997), the conceptual change theory proposed by Posner and colleagues for solely considering cognitive features. The researchers believed that new components such as ontological, epistemological, and social/affective dimensions are needed in conceptual change models. They further mentioned that students will have difficulty acquiring new concepts if the concepts are categorised in the incorrect ontological category. In this regard, they can be considered to have a logic that is similar to the suggestions made by Chi and colleagues. Furthermore, the researchers strongly believed that in addition to students' cognitive elements, ontological viewpoints of knowledge, as well as affective qualities such as motivation, should be taken into account when transferring incorrectly classified concepts to the correct category.

Alsop and Watts (1997) established a conceptual model with a four-dimensional structure: cognitive, conative, affective, and self-esteem. The four-dimensional conceptual model emphasises the role of not just cognitive but also affective factors on conceptual change (Alsop & Watts, 2000; Kural & Kocakulah, 2016). Alsop and Watts (1997) in dealing with the cognitive realm, highlight qualities of the new notion such as intelligibility, plausibility, and fruitfulness, as proposed by Posner and colleagues (1982).

The conative dimension in Alsop and colleagues' four-dimensional model of conceptual change has to do with the degree to which knowledge and understanding can be practically useful and made applicable. The conative dimension is concerned, with questions like: How can I put that knowledge to use? Is it giving me the courage to act? Is it assisting me in resolving a problem? Is that knowledge secure enough for me to apply it right away? From these questions, the researchers proposed a conative subgroup that included control, action, and trust in their conceptual change model.

The three subcategories, according to the researchers, fundamentally examine the amount to which learners can trust their understandings, the level of control they have over knowledge application, and the degree of applicability. The conative component includes students' knowledge of new idea features and activities for cognition. The conative component is an affective variable, not a cognitive one. Kural and Kocakulah (2016), argue that motivation which is seemly tied to conative is directly not addressed in Alsop and Watts's four-dimensional conceptual change model. The researchers further added that metacognition was also left out of the cognitive domain. The control subgroup in the conative dimension, on the other hand, is concerned with students' ability to recognise the properties of new concepts. For this reason, it can be said that metacognition is indirectly involved in this model. As a result, metacognition can be said to be incorporated into the model indirectly.

Alsop and Watts (1997) indicated that self-esteem comprises of subscale factors like image, confidence, and autonomy which also impact the conceptual change process significantly. They further assert that the factors include the students' statements on how much they trust themselves when learning science. They defined images as students' perceptions of their ability to connect observable facts to scientific knowledge. Confidence is defined as a student's determination to learn despite obstacles, while autonomy is defined as a student's willingness to solve problems or complete academic objectives.

Yildiz (2008) researched the effects of metacognition during instruction based on conceptual change in students learning. The researcher integrated motivation and metacognition in Alsop and Watts's Four-Dimensional model of conceptual change

into the study. Yıldız (2008) concluded that there is a positive effect of a metacognitive classroom atmosphere on students' learning, thus added metacognition to the factors influencing conceptual change. The metacognition in Yıldız's Metacognition Based Four-Dimensional Conceptual Change model is seen not only as a concept that is at the level of cognition but also as a concept that is about motivation (Pintrich, 2003). The metacognition having an affective dimension increased the temperature of the model.

The Cognitive Reconstruction of Knowledge Model (CRKM) as propounded by Dole and Sinatra (1998) is a model that elaborates on how the characteristics of the student (including motivation) interact with the characteristics of the new concept (message) during the conceptual change process. The Cognitive Reconstruction of Knowledge Model (CRKM) suggests a framework whereby characteristics of the learner's background knowledge, the learner's motivations for learning, and characteristics of the content students are learning interact to produce a degree of engagement with the new conception, and a likelihood of conceptual change (Sinatra & Pintrich, 2003; Taasobshirazi & Sinatra, 2011). In the Cognitive Reconstruction of Knowledge Model, motivation is viewed as a supplementary aspect of conceptual change in the model. Students will not be able to address the relationship between scientific concepts and their own if they are not motivated, according to Sinatra and Pintrich (2003). The CRKM claims that the power, stability, and consistency of students' assumptions influence conceptual change (Sinatra, 2005). Conceptual change is more likely to occur if the students' concepts are weakly linked and inconsistent with the conceptual framework. In CRKM, potential motivators include not only unhappiness but also the social situation. According to Kural and Kocakulah (2016), the new concept to be learnt is referred to as a message in CRKM. The message's properties have been recognised as comprehensibility, plausibility, coherence, and compelling. A message with a high

degree of these traits has a higher chance of being accepted by the learner (Lombardi & Sinatra, 2010). According to Dole and Sinatra (1998), the message and the affective traits of individuals interact in a manner that triggers an engagement along a continuum. The researchers further added that the engagement continuum is a necessary but not sufficient requirement for conceptual change. If there is no engagement continuum, however, conceptual change does not occur or only occurs weakly. If there is no conceptual ecology and the message is not clear or believable, it is required to check for the presence of a peripheral cue. Weak conceptual change can occur if a peripheral cue is available, but there is no conceptual change if there is none present (Dole & Sinatra, 1998; Kural & Kocakulah, 2016).

The Cognitive Affective Model of Conceptual Change (CAMCC) is a conceptual change model propounded by Gregoire (2003). According to Gregoire (2003), emotional responses to messages direct the level of engagement. The researcher argues that emotional responses occur before processing the message and “as part of the appraisal process, serve as additional information for individuals as they interact with a complex, stressful message” (Gregoire, 2003, p. 168). The researcher further indicated that positive and neutral emotions can lead to shallow, heuristic processing of the message. In contrast, negative emotions, such as fear and anxiety, promote deeper, systematic processing of the message. Similarly, Gregoire (2003) hypothesized that negative emotions would foster carefully weighing of the conflicting information. When the reform message is communicated in such a way as to initiate stress appraisal, it leads to conceptual change. On the other hand, the researcher mentioned that if the reform message did not initiate stress appraisal, the listener rejects the message and develops heuristic responses as shown in Figure 1.

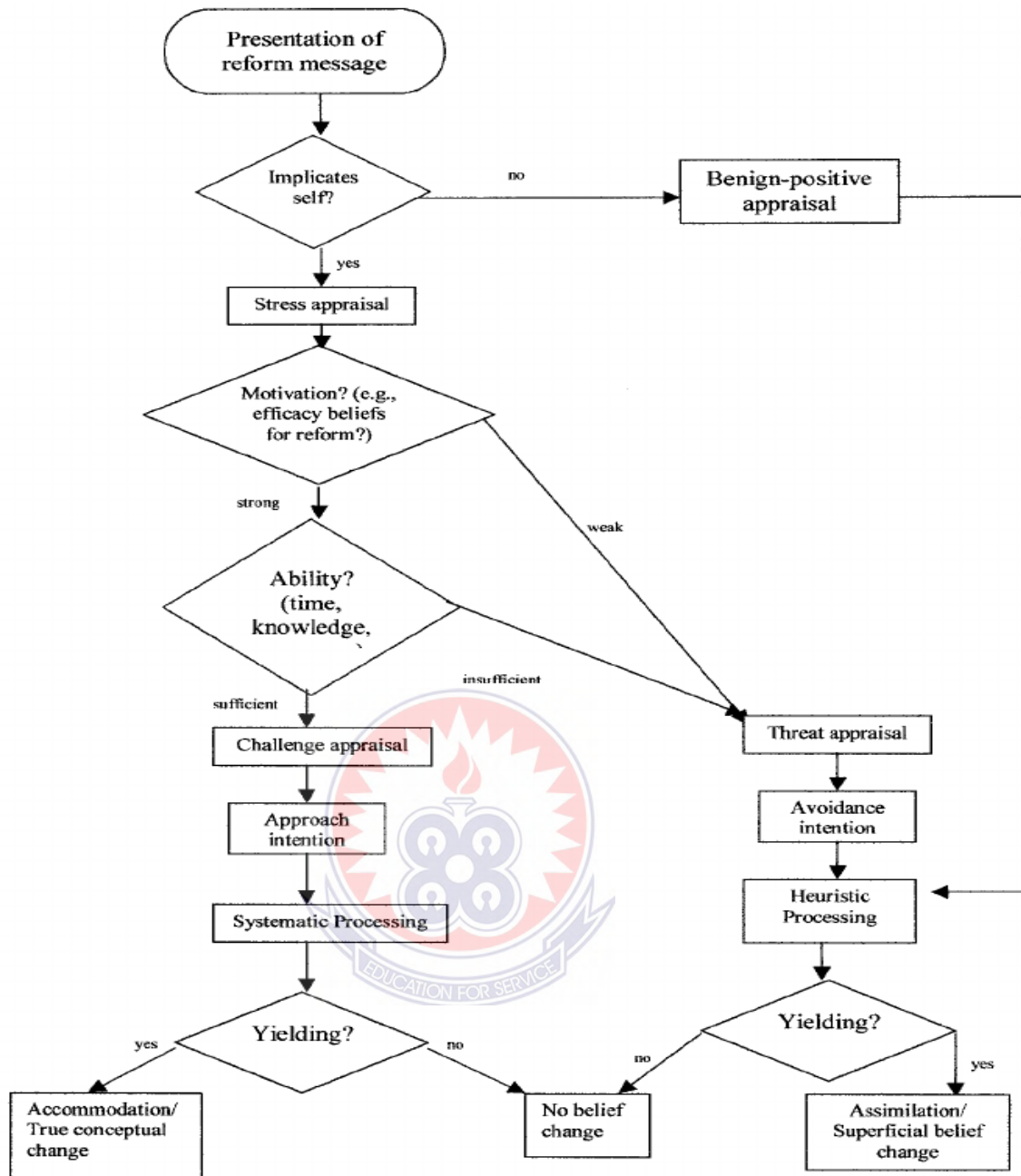

Figure 1: Cognitive Affective Model of Conceptual Change.

Source: Gregoire, 2003

Kural and Kocakulah (2016) after studying the earlier conceptual change models were of the view that most of the conceptual change models were seen at a theoretical level, with little to no indication of how they would be implemented in a regular lesson. The researchers further added that most of the models had a shortfall either in the affective

domain or in the area of metacognition. Kural and Kocakulah (2016) presented a novel conceptual change paradigm called Teaching Model for Hot Conceptual Change, which uses the conceptual change model by Posner et al (1982) backed by motivational and metacognitive strategies.

Motivation, one of the most essential affective factors, must be taken into consideration during conceptual change (Palmer, 2005). The Teaching Model for Hot Conceptual Change is supported by several motivational strategies. A right teaching atmosphere, argumentation/ group work, provision of clear accurate and realistic academic feedback and discussions are some of the motivational strategies adopted in the TMHCC that help raise students' motivation (She, 2002; Pintrich, 2003; Zhou, 2010).

According to Flavell (1979), as cited in Jaleel (2016), metacognition is the knowledge about and regulation of one's own cognitive activities in learning processes. Metacognition is commonly referred to as thinking about thinking according to Jaleel (2016). Metacognition, according to the researcher, is a regulatory mechanism that lets a person comprehend and manage their own cognitive performance. People can use metacognition to take control of their own learning. Going meta while talking about metacognition, according to Jaleel (2016), is the process of taking a step back to view what you are doing as if you were someone else watching it. Metacognition is divided into two areas as metacognitive knowledge (awareness of one's thinking) and metacognitive regulation (the ability to manage one's own thinking processes) according to Flavell (1979), as cited in Jaleel (2016). "How do I study best?" or "What types of instruments assist me to learn?" are examples of questions that clearly utilise metacognitive knowledge. This might include anything from information that helps students evaluate their own skills and intelligences to reflections on specific learning

processes that students employ in various settings. Metacognitive regulation refers to the ability to think strategically, solve issues, define objectives, arrange thoughts, and assess what is known and unknown. It also entails the capacity to instruct others and make one's own thought process evident (Jaleel, 2016).

According to Phromsena et al. (2019), any teacher who wishes to implement the Teaching Model for Hot Conceptual Change in a class must first motivate students in the learning context. Students must be engaged in the content and aware of the subject's fascinating aspects in order to engage in meaningful cognitive conflict (Limón, 2001; Sinatra, 2005). Secondly, the teacher must elicit students' ideas and preconceptions by asking questions that arouse their metacognition and help students become more conscious of their biases and prepare them for significant cognitive confrontation (Phromsena et al., 2019). The researchers further indicated that the teacher must overview students' conceptions/knowledge and categorises those in conflict with the scientific knowledge. Again, teachers must create cognitive conflict in the student's mind. At this point, teachers are supposed to incorporate the students' deviations from existing notions into the instructional environment. Students will be driven to replace their assumptions with scientific ones and to observe the characteristics of new concepts if they are taught in this manner. Furthermore, teachers must employ group work/argumentation. In the group work or argumentation section, students are provided academic and motivational feedback. Students are asked questions such as why is your expression intelligible/believable or did you truly comprehend the offered content throughout group work and argumentation stages, which will test their metacognition. The next stage in the TMHCC is the introduction of the scientific concept (Kural & Kocakulah, 2016; Phromsena et al., 2019). According to the researchers, at this stage, the outcomes of group work and debate are utilised to introduce scientific concepts to

students. Students use this step to challenge their ideas and replace them with new, scientific ones. Following the introduction of the scientific concept, the teacher must provide opportunities for students to transfer the new concepts to different problems. Lastly, the teacher evaluates the learning outcome (Kural & Kocakulah, 2016). According to the researchers, at this stage, students are given series of questions to determine what their pre-and post-instruction conceptions are if their concepts have changed, and if so, which aspects of the teaching caused the change. As a way of motivation, the teacher should strive to elicit beneficial and engaging aspects of activities, as well as the value of knowledge taught.

2.2 Constructivism

Constructivism is a learning theory in which learning is both an active process and a personal representation of the world (Christie, 2005, as cited in Aina, 2017). Similarly, Mascolo and Fischer (2005) opine that constructivism is a learning theory that avows that the best way to acquire knowledge is by active mental creation and reflection. Robottom (2004) describes knowledge as the creation of concepts in the learner's mind. The student gains knowledge by reflecting on what is being taught and constructing an interpretation based on past experiences, personal beliefs, and cultural background. Psychological constructivism and social constructivism are the two main forms of constructivism (Kanselaar, 2002).

2.2.1 Psychological constructivism

Psychological constructivism's central tenet is that people learn through cognitively structuring and rearranging new knowledge and experiences (Mogashoa, 2014). The cognitive theory of Jean Piaget is an example of psychological constructivism (Piaget, 2001). Assimilation (interpretation of new information in terms of pre-existing

concepts, information, or ideas) and accommodation (revision or modification of pre-existing conceptions in terms of new information or experience) are the two mental acts that Piaget (2001) defines as learning. According to Mogashoa (2014), psychological or Piagetian constructivists consider the objective of education as educating the individual kid in a way that supports the child's interests and needs; as a result, the child is the topic of research, and individual cognitive development is the focus. Constructivism, according to Wales (2010), is an epistemological foundation based on the belief that the human mind actively provides meaning and order to the world to which it is responding in the act of knowing. Learning is seen as essentially a personal endeavour. This method posits that students enter the classroom with pre-existing ideas, beliefs, and views that must be influenced by a teacher, who aids this modification by designing activities and questions that provide learners with challenges (Mogashoa, 2014). As a result of overcoming these hurdles, knowledge is constructed.

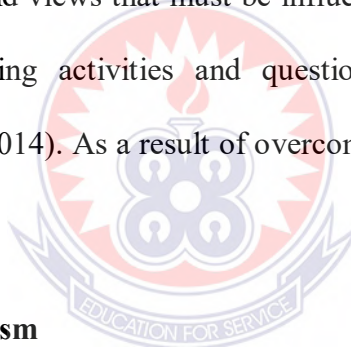

2.2.2 Social constructivism

Social constructivism, according to Kim (2001), emphasizes the relevance of culture and context in comprehending what happens in society and developing knowledge based on this understanding. According to Au (2005), the goal of instruction, the role of the home language, instructional materials, classroom management and interaction with students, relationships with the community, instructional methods, and assessment will all improve school literacy learning for students of diverse backgrounds in social constructivism. The researcher indicated that humans create or generate knowledge. Language and writing systems are cultural tools that people in various civilizations have developed and made available to them. Learners from all backgrounds should be encouraged to use their native languages as a foundation for

literacy development in schools. The researcher further suggest that teachers in a social constructivist learning environment are not to leave students to their own devices, but rather to assess what is necessary for actual knowledge of the topic and to move among students to help them improve their conceptions. The teacher must assist students in making the concepts to be learnt meaningful at their own levels.

According to Au (2005), school literacy learning for kids from all backgrounds can increase if instructors recognize the relevance of students' native languages and come to consider biliteracy as a feasible and desirable goal. Schools are socio-cultural spaces in which teaching and learning take place, as well as the application of cultural skills such as reading, writing, mathematics, and particular kinds of speech (Mogashoa, 2014). This idea suggests that theory and practice are shaped by dominant cultural beliefs rather than developing in a vacuum. Teachers should employ assessment methods that minimize sources of error and accurately represent students' reading abilities. Learning, according to social constructivists, is a social activity, and knowledge is a human product. Interaction with adults can help young toddlers improve their cognitive abilities.

Five causes for the reading success gap emerge from a social constructivist perspective: language disparities, cultural differences, discrimination, inadequate education, and educational logic (Au, 2005). The collective social accomplishments of educational systems, communities, instructors, students, and families determine both success and failure in literacy learning. Communication or discourse processes are compared to construction processes in constructivism. The emphasis is on generative acts, such as those of interpreting or composing texts. Themes in constructivist work include active engagement in processes of meaning-making, text comprehension as a window on these

processes and the varied nature of knowledge, especially knowledge developed as a consequence of membership in a given social group (Au, 2005). Social constructivism holds the idea that there is no objective basis for knowledge claims because knowledge is always a human construction.

The emphasis is on the social group's process of knowledge building and the intersubjectivity produced through group interaction. The role of instructors, classmates, and family members in mediating learning, the dynamics of classroom teaching, and the organization of systems within which children learn or fail to learn are all explored in social constructivist literacy research (Au, 2005).

2.2.3 The constructivist view of the role of the learner

According to Hein (2007), in a constructivist class, students are required to think about the content being taught and build an interpretation during the learning process. The author added that student does the interpretation based on previous experiences, personal perspectives, and cultural background. Furthermore, the student is asked to reflect on his or her new information after the interpretation. The student is expected to engage and interact with the environment, their peers, authorities, and instructional resources. In a constructivist class, the researcher argues that the learner develops knowledge and meaning by actively engaging in the activity, seeing how things and ideas interact and developing a cognitive framework to make sense of it all. The student is typically allowed to follow their interests if they constantly challenge themselves and generate new ideas. There is no rivalry among students in a constructivist class. Students are expected and encouraged to collaborate and share information and ideas (Hein, 2007). Students frequently assume the role of a teacher in areas where they have special expertise, aiding their classmates while also reinforcing their knowledge.

2.2.4 The constructivist view of the role of the instructor

According to Alzahrani and Woollard (2016), due to constructivism's nature, the educator must adopt a more hands-on approach rather than the typical lecture technique. The classroom setting should be supportive of each learner's thinking while yet providing an ongoing challenge. Instructors, not teachers, must adapt to the position of facilitators, according to the social constructivist approach (Alzahrani & Woollard, 2016). Instead of merely describing a principle, a facilitator assists the student in arriving at his or her comprehension of the material. The facilitator must behave differently than a teacher as the emphasis shifts to a more active teaching process (Brownstein, 2001). A facilitator, according to Amineh and Asl (2015), asks questions, offers support from the back, provides guidance, and creates an atmosphere in which the learner may come to his or her conclusions, and finally, the facilitator is in constant communication with the students. In a constructivist classroom, according to Tam (2000), information is exchanged between instructors and students. The instructor serves as a facilitator or guide for the students and shares authority with them. Tam (2000) described a constructivist class to consist of learning groups that are made up of small groups of students with various qualities. This implies that teachers are obliged to put students in smaller groups while ensuring an even distribution of qualities across the groups.

2.3 Conceptual Change and Conceptual Change Approach to Teaching

Learning in scientific classrooms can take place under at least three different prior knowledge circumstances (Gafoor & Akhilesh, 2010). Gafoor and Akhilesh (2010) posit that students may have no prior knowledge or information about the concepts to be learnt in the first condition, yet they may have some related knowledge. In this scenario, prior knowledge is lacking, and learning entails the acquisition of new

information. In the second scenario, a student may have some right prior knowledge of the ideas to be learned, but this information is insufficient. Learning can be thought of as gap-filling in this scenario. This implies that knowledge acquisition is enriching in both missing and incomplete knowledge situations. In a third scenario, a student may have developed views that are incompatible with concepts to be learned, either at school or through everyday experience (Vosniadou, 2004). According to Gafoor and Akhilesh (2010), the third type of knowledge acquisition is conceptual change. They posit that existing knowledge is presumed to be inaccurate or erroneous and that the material to be learned is correct. As a result, learning in this third situation does neither contribute new knowledge nor fill up gaps in existing knowledge. Learning, on the other hand, is the transformation of previously incorrect knowledge into correct scientific knowledge. This is referred to as the conceptual change process. Conceptual change is often associated with the introduction of new concepts, elimination of old concepts, introduction of new subordinate classifications, and sometimes even alteration of the whole method of classification (Thagard, 2014). In general, conceptual change is defined as learning that changes an existing conception (Davis, 2001). Gleaning from above, conceptual change learning is distinguished from other forms of learning by the shift or restructuring of knowledge and beliefs. The change creates a conceptual framework that may be used by students to solve problems in the future. The conceptual change approach to teaching is a way of teaching which primarily involves uncovering students' misconceptions about a particular topic or phenomenon and using various techniques to help students change their conceptual framework to scientifically acceptable one.

According to Denis, Williams, Dunnamah, and Tumba (2015), a teacher who wants to teach using a conceptual change approach should know the methods, concepts, principles, and theories that constitute the science they are teaching. Again, the teacher

should know what conceptions their students hold about the units to be taught, and the extent to which they are scientifically acceptable. The teacher must be aware of the role played by students' existing knowledge in understanding new material. One should be convinced of the need to use conceptual change teaching strategies particularly when students' existing conceptions conflict with those being taught, and lastly must be able to plan and perform teaching actions that give effect to these strategies. When planning for conceptual change teaching, a teacher needs to foster a learning environment that will support conceptual change learning. This can be via providing opportunities for discussion, and consideration of alternative viewpoints and arguments. The teacher must consider the selection of specific learning activities, as well as the fact that the learning activity must satisfy the science domain's requirement (Denis et al., 2015).

2.4 Relevance of the Conceptual Change Approach to Teaching

Consistent evaluation and clarification of conceptions during the conceptual change process help students develop metaconceptual awareness; that is, they come to understand how they develop their beliefs (Vosniadou, 2007). Conceptual change learning results in better conceptual understanding by the students (Davis, 2001). These help to instil confidence in the students and ultimately improve students' academic achievement in physics.

2.5 Performance of Students in Physics

Over the years, physics students' performance in Ghana has typically and regularly been poor (Anamuah-Mensah, 2007). One of the reasons for low performance in physics is a lack of conceptual understanding (Hake, 1998). Students may struggle to grasp fundamental concepts, leading to difficulties in applying them to problem-solving tasks (McDermott & Shaffer, 1992). Misconceptions, or alternative conceptions, are

prevalent among students and can hinder their ability to understand and apply physics principles accurately (Chi, 2005). These misconceptions may arise from students' prior knowledge or everyday experiences (Duit & Treagust, 2003). These misconceptions may persist despite traditional instruction, making it essential to address them explicitly in teaching. Various instructional strategies have been proposed to identify and address misconceptions effectively. Some of those strategies are conceptual change approaches and active learning techniques like interactive demonstrations, concept mapping, and problem-based learning (Prince, 2004; Chi, 2008). These approaches emphasize the importance of providing opportunities for cognitive conflict, reflection, and conceptual restructuring (Chi, 2008).

Another notable cause of low performers in physics stem from the ineffective teaching strategies used by teachers. Traditional teaching methods that rely heavily on lectures and rote memorization may not effectively engage students or promote deep learning in physics (Duncan, Breslow, & Elby, 2018). Passive learning environments can lead to disinterest and disengagement among students (Freeman, Eddy, McDonough, Smith, Okoroafor, Jordt, & Wenderoth, 2014). Research has shown that active learning approaches, such as interactive engagement and hands-on activities, are more effective in promoting conceptual understanding and improving student performance in physics (Hestenes, 2006; Wieman & Gilbert, 2014).

Similarly, physics often involves complex mathematical concepts and calculations, which can pose challenges for students with weaker mathematical skills (Adams & Wieman, 2011). Difficulties in understanding and applying mathematical principles may impede students' progress in physics courses (Redish & Steinberg, 1999). Addressing mathematical prerequisites and providing additional support for mathematical skills development can help improve student performance in physics.

More so, low motivation and confidence are key factors that to also contribute to low performance in physics (Glynn, Taasoobshirazi, & Brickman, 2011). Students who perceive physics as difficult or irrelevant may be less motivated to engage with course materials and assignments (Meltzer & Manivannan, 2002). Similarly, misconceptions can also affect students' confidence and motivation in learning physics (Adams & Wieman, 2011). Students who struggle with misconceptions may become disengaged or frustrated, further exacerbating their performance issues (Meltzer & Thornton, 2012). The motivation and confidence in learning physics by students are enhanced when teachers provide opportunities for hands-on experimentation, real-world applications, and collaborative problem-solving, (Ainley & Ainley, 2011; Hulleman et al., 2008).

In addition, socioeconomic status and cultural background can influence students' access to educational resources and opportunities, affecting their performance in physics (Buchwald, 2017). Students from marginalized or underrepresented groups may face additional barriers to success in physics education. Addressing equity issues and promoting diversity in physics education are essential for fostering inclusive learning environments and improving student outcomes (Seymour & Hewitt, 1997).

Low performance among students in physics can stem from a combination of factors, including conceptual difficulties, ineffective teaching methods, mathematical challenges, lack of motivation, and socioeconomic disparities. Addressing these factors requires a multifaceted approach that integrates active learning strategies, mathematical support, motivational interventions, and equity-focused initiatives to promote success for all students in physics education.

2.6 Studies on Students' Misconception about Electricity

Electricity is viewed as a crucial topic in physics yet difficult a one due to its abstract

nature (Mboniyirivuze, Yadav, & Amadalo, 2022). Therefore, students tend up having a variety of misconceptions about it. The presence of misconceptions about electricity among students hinders learning it. As a result, researchers have conducted a plethora of studies on students' misconceptions about electricity, particularly simple direct current circuits (Sencar & Eryilmaz, 2004; Küçüközer, & Kocakulah, 2007; Aboagye 2009; Gunstone, Mulhall, & McKittrick, 2009; Mboniyirivuze et al., 2022). Misconceptions can exist regardless of society, religion, or language.

Sencar and Eryilmaz (2004), list nine models of misconceptions commonly found in literature as the sink model, clashing current model, weakening current model, empirical rule model, empirical rule model, local and sequential reasoning model, short circuit preconception model, power supply as a constant current source model and parallel circuit misconception model. According to Sencar and Eryilmaz (2004), in the sink model students tend to believe that a single wire connection allows the electricity to sink from the acting power supply to the component, providing power to the applicable. The researchers further argue that students who believe in the clashing current model think that positive electricity flows from the positive terminal of the power supply and negative electricity flows from the negative terminal of the same power supply, resulting in the positive and negative currents colliding. The component is said to be powered by the energy generated by this collision. Students who believe in the weakening current model think that the current weakens as it goes through the circuit's components, with each component using a percentage of the available current as it passes through it. Again, students tend to assume that all components in the circuit receive the same amount of current and that less current returns to the appropriate power source than is left at the start of the circuit when using the shared current model. Students that believe in the empirical rule mode think that the further a bulb is from the

power source, the dimmer it is. Sencar and Eryilmaz (2004) further posit that, pupils who believe in the local and sequential reasoning model believe that any changes in the circuit influence only that local region and have no effect on the circuit as a whole. With the short circuit misconception model, students tend to believe that the wire connections without components can just be ignored as they are seen to be irrelevant to the circuit as a whole. When students tend to believe that the power supply releases a fixed quantity of current to every possible circuit then they have power supply as a constant current source model misconception. Similarly, when students tend to believe that adding resistance in parallel to a circuit increases the total resistance, then they have the parallel circuit misconception model

In analysing circuits, students use either the reasoning, sequential, local or superposition (Ates, 2005). According to Closset (1983), students using sequential reasoning believe that current is influenced by each circuit element as it is encountered and a change made at a particular point does not affect the current until it reaches that point. Similarly, Rhöneck and Grob (1987) posits that students who uses local reasoning believes that current divides into two equal parts at every junction regardless of what is happening elsewhere. Students using superposition reasoning would infer that if one battery makes a bulb shine with a certain brightness, then two batteries would make the bulb shine twice as bright regardless of the arrangement (Sebastia,1993).

Students' comprehension of direct current resistive electrical circuits was investigated by Engelhardt and Beichner (2004). They discovered that the thinking processes of both high school and university students in regards to direct current resistive electric circuits frequently diverge from the commonly accepted answers. They claimed that even after education, students had various misunderstandings. The assumption that the battery

provides a steady source of current was most frequently mentioned during interviews. In addressing the issues, students tended to focus on current and to conflate concepts, often attributing current attributes to voltage and/or resistance. The basic mechanics of electrical circuit phenomena are not well understood by students. Students, on the other hand, were able to effortlessly transfer a realistic portrayal of a circuit to the schematic design that accompanied it.

Küçüközer and Kocakulah (2007) aimed at revealing secondary school students' misconceptions about simple electric circuits. Seventy-six (76) students in the three grade 9 classes in the city of Balikesir in Turkey participated in the study. The results revealed the following misconceptions specific to Turkish students. Firstly, none of the bulbs will light when the circuit is closed, bulbs in parallel are always brighter than those in series, batteries are constant current sources and current is consumed by circuit components. The sources of such misconceptions were found to emerge from everyday use of language and misconceptions acquired during teaching.

Aboagye (2009) investigated the effects of some teaching approaches on students understanding of selected concepts in electricity using 101 physics students as participants. The participants were chosen from one intact form 3 class from two different schools in the New Juaben Municipality. The results of the study showed that students are as follows the following misconception. Firstly, the brightness of a bulb connected in series to dry cells connected in parallel will increase because the voltage of the cells will increase; the brightness of bulbs connected in series will decrease because the current will be shared among the bulbs; current is consumed or used up by circuit elements or resistors; voltage is constant in a series circuit, the brightness of bulbs connected in parallel to a dry cell will decrease because the source voltage is

shared among the bulbs in the circuit. The voltage is shared equally among resistors connected in parallel in a circuit; and resistance decreases the voltage in a circuit.

Aligo, Branzuela, Faraon, Gardon and Orleans (2021) conducted a study aimed at determining the most common misconceptions about electricity among students and science teachers and to shed light on this problem. The study utilised a written test to survey the students and teachers' misconceptions about electricity, and a semi-structured interview of students to confirm the results of this test. The results from the test and interviews indicated that students and science teachers share some common models of misconceptions about electricity like the clashing current, shared current, current flow as water flow, short circuit, and local reasoning models. The researchers recommend using different strategies to improve the students' and teachers' conceptual understanding of electricity to address these misconceptions and lack of knowledge.

However this study will only focus on the misconceptions held by students on current electricity and how they could be dealt with using the teaching model for hot conceptual change (TMHCC).

2.6 Conceptual framework

In this study, the Teaching Model for Hot Conceptual Change (TMHCC) was selected as the conceptual change model to be utilised as a teaching strategy aimed at enhancing students' understanding of physics, particularly in current electricity. The choice of TMHCC was based on its contemporary relevance and its recognition as an advancement over previous conceptual change models. Given the importance of adapting educational strategies to diverse contexts, the researcher sought to explore how the TMHCC could be implemented in Ghanaian classroom and assess its effectiveness within that specific cultural and educational context. This would provide

valuable insights into the applicability and effectiveness of the TMHCC in settings outside its original context, contributing to the global understanding of effective teaching methodologies. Figure 2 depicts the application of the Teaching Model for Hot Conceptual Change (TMHCC), as proposed by Kural and Kocakulah (2016), in teaching the concept of current electricity with the objective of enhancing students' conceptual understanding and consequently improving academic performance. The conceptual framework presented here is adapted from the model proposed by Kural and Kocakulah (2016).



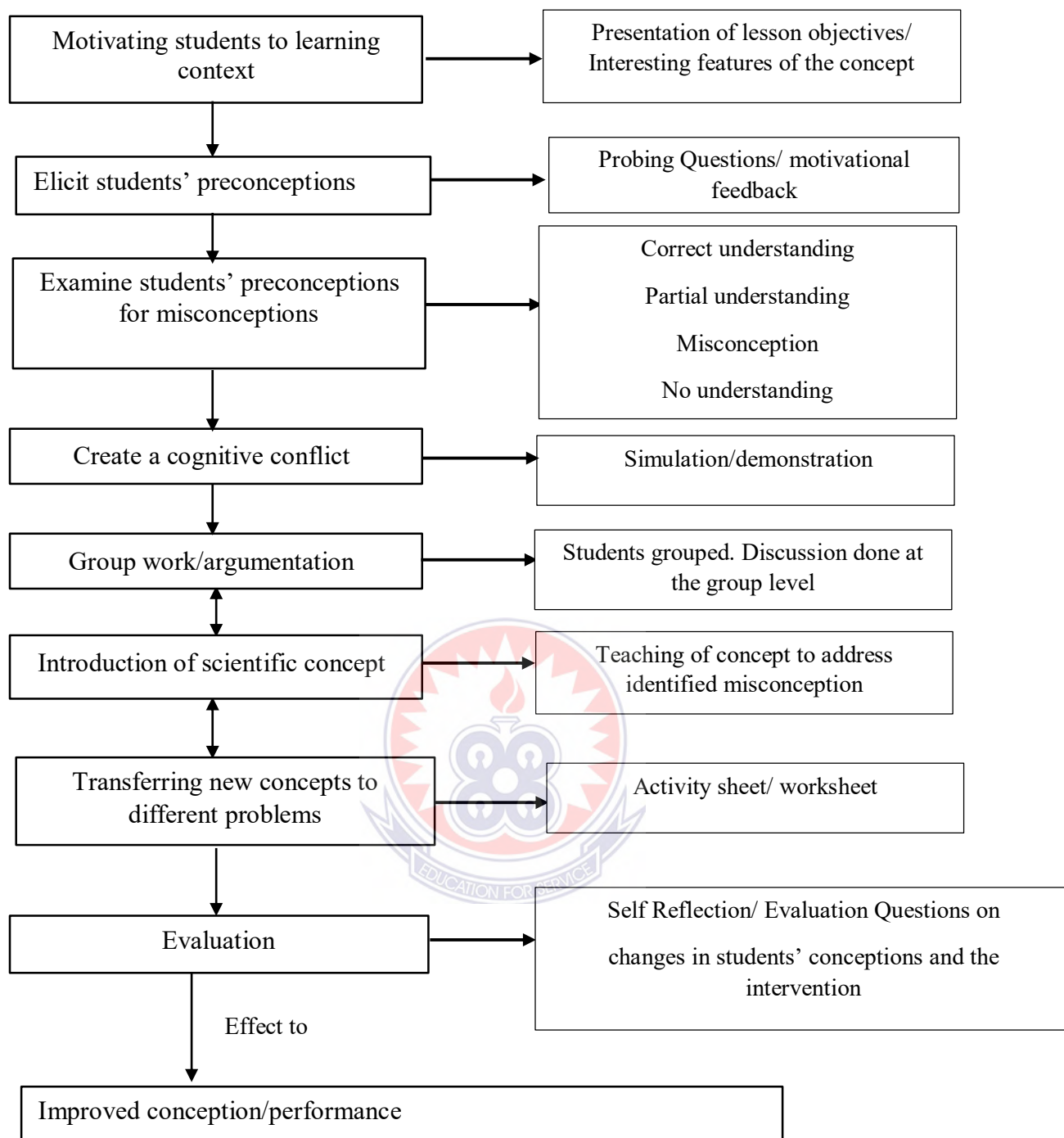

Figure 2: Adapted Conceptual Framework for Implementing the Teaching Model for Hot Conceptual Change (TMHCC) to improve students' conceptions

Source: Kural and Kocakulah (2016)

From Figure 2, the teaching model for hot conceptual change starts with the teacher motivating the students to the learning context. This is done by presenting the lesson objectives to the students or drawing awareness to the fascinating aspects of the

concept. Secondly, the teacher elicits students' preconceptions by asking probing questions. The teacher applauds student for their responses but does not comment on them. Thirdly, the teacher examines students' preconceptions stated earlier, categorises them and identifies those in conflict with the scientific knowledge. The teacher then creates cognitive conflict in the student's mind by making students watch a predict-watch -explain animation on the concept. Afterwards, the teacher groups the students so that the discussion of the animation could be done at the group level. Group leaders take turns presenting their findings. The next stage in the TMHCC is the introduction of the scientific concept. At this stage, the outcomes of group work and discussion are utilised to introduce scientific concepts to students. Students use this step to challenge their ideas and replace them with new, scientific ones. Following the introduction of the scientific concept, the teacher provides opportunities for students to transfer the new concepts to different problems through the usage of activity sheets/worksheet. Lastly, the teacher evaluates the learning outcome with the students. Students are asked to reflect on the whole teaching and learning process and examine their pre and post-intervention conceptions for possible changes. Students are given opportunities to evaluate the strengths and weaknesses of the instruction and give some recommendations to the teacher for the next lesson.

Phromena et al. (2019) examined the effects of the teaching model for hot conceptual change on students' chemistry conceptions. The study was a one-group pretest-posttest design that aimed to study the percentage of students who developed chemistry conception after having learned chemistry through TMHCC. Participants were 42 eleventh-grade students who were studying in the science program of a public secondary school in Phrae Thailand. The study concluded that 52.58% of the students had a change in their chemistry conception after the implementation of TMHCC.

Similarly, Kural, and Kocakülah (2016) investigated the influences of the TMHCC on the student's conceptual understanding, motivations, and attitudes toward physics. The study consisted of 40 students from two grade 11 science classes in Anatolian Teacher-High School of a district in Manisa in Turkey. The study concluded that TMHCC helped students to change their prior knowledge toward acceptable scientific conceptions.

Gleaning from above the implementation of the teaching model for hot conceptual change positively affects the conceptions students bring to class and increases students' academic performance.

2.7 Chapter Summary

Conceptual change models are models that elucidate how students' misconceptions could be addressed if followed. Posner et al.'s (1982) conceptual change theory, Chi et al.'s (1994) theory of conceptual change, Tyson et al.'s (1997) three dimensional model of conceptual change, Alsop & Watts's (1997) four-dimensional model of conceptual change, Yıldız's (2008) metacognition based four-dimensional conceptual change model, Dole and Sinatra's (1998) cognitive reconstruction of knowledge model (CRKM), and Gregoire's (2003) cognitive-affective model of conceptual change (CAMCC) and Kural and Kocakülah's (2016) Teaching Model for Hot Conceptual Change (TMHCC) are some of the conceptual change models found in the literature (Kural & Kocakülah, 2016, Phromsena et al., 2019). The Kural and Kocakülah's Teaching Model for Hot Conceptual Change (TMHCC) is current and takes into consideration the cognitive and affective characteristics of the students as well as metacognition. The cognitive and affective characteristics of the students as well as metacognition are key factors in the conceptual change process .

Constructivism is a learning theory which is learner-centred and students acquire knowledge through active mental creation and reflection. Psychological constructivism and social constructivism are the two main forms of constructivism. Psychological constructivism and social constructivism are the two main forms of constructivism (Kanselaar, 2002). The primary role of the teacher in constructivism is to create a collaborative problem-solving environment where students become active participants in their own learning. On the other hand, students are expected to consider the information being taught and construct an interpretation based on past experiences, personal views, and cultural background and then reflect on the new knowledge.

Conceptual Change Approach to Teaching is teaching using any of the conceptual change models as a teaching strategy to change students' misconceptions to conform with scientific knowledge. The conceptual change approach to teaching helps students to develop meta-conceptual awareness, results in better conceptual understanding by the students (Davis, 2001), instils confidence and ultimately improves students' academic performance in physics.

Students have a variety of misconceptions about electricity due to its abstract nature. The sink model, clashing current model, weakening current model, empirical rule model, empirical rule model, local and sequential reasoning model, short circuit preconception model, power supply as a constant current source model and parallel circuit misconception model are some of the misconceptions students have about electricity (Sencar & Eryilmaz, 2004; Küçüközer & Kocakulah, 2007; Aboagye, 2009; Aligo et al., 2021). Furthermore, students tend to use either the reasoning, sequential, local or superposition when analysing circuits (Ates, 2005).

CHAPTER THREE

METHODOLOGY

3.0 Overview

This chapter outlines the research methodology used for the study. The chapter describes the research design and research instruments used in the study. It also justifies the selection of the samples and research instruments and also indicates how issues of validity and reliability were addressed.

3.1 Research Design

Cohen, Manion, and Morrison (2018) define research design as the structural framework of a study that specifies the theory and methodology to be used, the types of data required, the instrumentation, from whom (the population and sample), how the data will be analysed, interpreted, and reported, the warrants to be adduced to support the conclusions drawn, and the degree of trust that can be placed in the findings. This study followed an action research design.

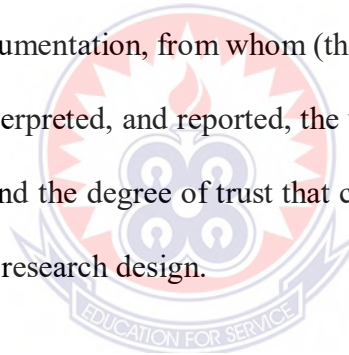

3.1.1 Action Research Design

Action research is a small-scale intervention in the functioning of the real world to address practitioners' own issues and a close examination of the effects of such an intervention (Cohen et al., 2018). Cohen et al. (2018) outline an eight-step process to follow when using action research. The eight steps are problem identification, possible interventions to address the problem, a decision on a particular intervention, planning the intervention with success criteria, implementing the intervention, monitoring and record implementation /effects, reviewing and evaluating the intervention, and how well intervention solved the problem. Figure 3 shows the cyclical procedure for action research.

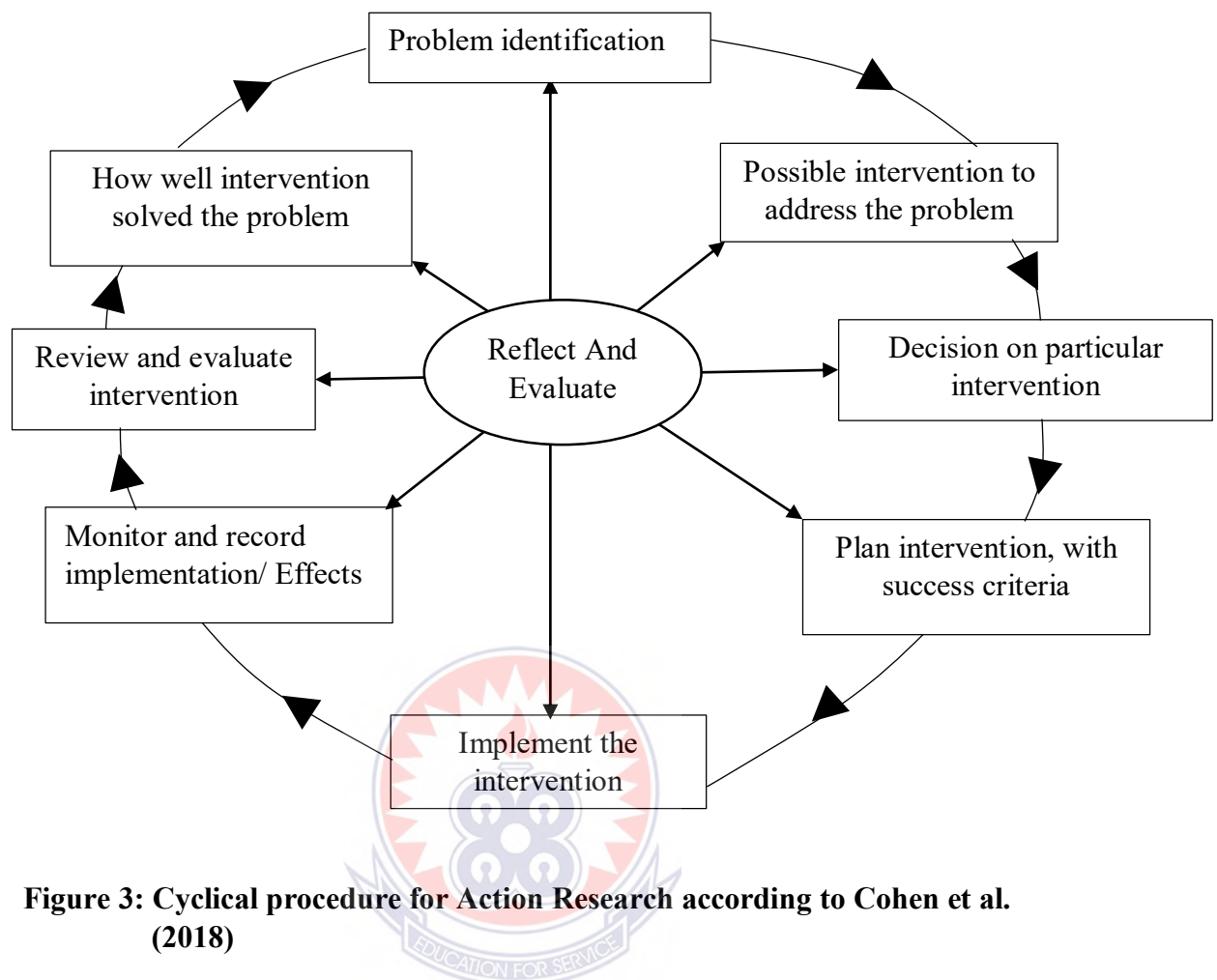

Figure 3: Cyclical procedure for Action Research according to Cohen et al. (2018)

The first step involves problem identification. The researcher focused on a single issue which was on seeking a solution to problems of instructional strategies to improve students' performance. The researcher identified the problem as the low performance of students in physics owing to the rich and robust misconceptions students come to class with. These misconceptions are at variance with scientific knowledge and students rely on them to interpret and make sense of the new concepts being taught. Students end up having gaps in their understanding which ultimately affects their performance. A possible intervention to address this problem is through a conceptual change approach to teaching physics. This choice was informed by literature on the conceptual change approach to teaching. According to Davis (2001), the conceptual

change approach to teaching is a strategy that is particularly effective in remedying students' misconceptions, resulting in deeper conceptual understanding and ultimately higher academic performance. The teaching model for hot conceptual change propounded by Kural and Kocakulah (2016) was used as the intervention for this study. The Teaching Model for Hot Conceptual Change (TMHCC) is current and takes into consideration the cognitive and affective characteristics of the students as well as metacognition. The cognitive and affective characteristics of the students, as well as metacognition, are key factors that influence the conceptual change process and therefore determine to a great extent the success of the conceptual change. The teaching invention using TMHCC was planned and implemented over a course of two weeks to teach direct current electricity. The change in students' misconception to acceptable scientific knowledge as well as an increase in performance are the criteria adduced to the success of the intervention. All the students in Form Two Agric One (2Ag1) were used for the study and the researcher was their physics teacher. The group took a pre-test, followed by an intervention, and then finally a post-test. Within the course of the intervention, qualitative data were also taken using field observation and activity sheets. The study employed mixed methods, where both quantitative and qualitative approaches were followed. According to Cohen et al. (2018), mixed method research is a study conducted by one or more researchers that include diverse components of both quantitative and qualitative research methodologies, as well as the type of conclusions drawn from the research. According to the researchers, the purpose of the mixed method is to give a richer, and more reliable understanding of a phenomenon than a single approach would yield. According to Creswell and Plano Clark (2011), mixed method research can provide explanations of the mechanisms behind phenomena as well as diverse perspectives on them, enhancing the relevance

and credibility of the findings and enabling the discovery of unanticipated findings. In situations when data is acquired using many approaches to examine how the findings converge, the utilisation of mixed method research acts as a source of triangulation. Quantitative methods focus on testing explanations, capturing standardised data and statistical analysis (Johnson and Onwuegbuzie, 2004). The strength of quantitative research lies in its reliability that the same measurements should yield the same results time after time. Quantitative data was gathered in the study using the pre-test and post-test scores.

The method of naturalistic inquiry that aims to get a thorough knowledge of social phenomena in their natural settings is known as qualitative research. In qualitative research, non-numerical data is gathered and analysed to better comprehend ideas, viewpoints, or experiences. It might be utilised to uncover intricate details about an issue or come up with fresh study concepts. Qualitative data was gathered in the study using field notes during the teaching intervention, and the focused group interview. Thus, in implementing a the Teaching Model for Hot Conceptual Change and determining its effect on the students' conception of some selected topics in current electricity, both quantitative and qualitative data were utilised.

3.2 Population

The population of a study comprises individuals, groups, organisations, or other things that the research is focused on and to whom the study's findings may be applied or generalised (Casteel & Bridier, 2021). The target population for the study consists of all the science students offering physics at Winneba Secondary School in the Effutu Municipality. The accessible population for this study was all Form 2 physics students in Winneba Senior High School in the Effutu Municipality.

3.3 Sample and Sampling Procedure

One intact class (Form 2 Agric1) with a class size of 40 students was purposively selected for the study. Purposive sampling is a sample method where researchers handpick the cases to be included in the sample on the basis of their judgment of their typicality or possession of the particular characteristic being sought (Cohen et al., 2018). The Form 2 Agric1 class was purposively selected because they had a lower performance in physics on average as compared with other science classes (Field survey, 2022). The low performance may be attributed to the many misconceptions they battled with. These misconceptions became more evident especially when students were asked to give reasons or explain a particular concept. Therefore, the Form 2 Agric1 possesses the characteristics the researcher was interested in. Therefore, the researcher sought to implement the teaching model for hot conceptual change to improve students' conceptions in current electricity leading to higher academic performance. The whole population of the class participated in the pre-test. The same sample took part in the intervention where the teaching model for hot conceptual change was implemented. After the intervention, a post-test was administered which measured the students' performances on the concept taught.

3.4 Research Instruments

Research instruments are measurement tools designed to obtain data on a topic of interest from research subjects. The research instruments used in the study were pre-intervention and post-intervention tests, focused group interviews and field observations.

The study used a test item developed by the researcher. In developing the test items, the topic “direct current electricity” in the senior secondary school syllabus and

textbooks were consulted. This helped the researcher in developing the test items. The test covered the following concepts: current, voltage, Ohm's law, resistance, series, and parallel connection of electrical components (cells, resistors and bulbs) respectively. The tests were given to students to assess their conceptual understanding and consequently their academic performance in the selected topics in current electricity. In all, twelve (12) tests comprising six pre-intervention tests and six post-intervention tests were administered to students. The test consisted of short answer questions. Researchers have suggested that short answer test items can effectively assess students' higher-order thinking skills and promote deeper learning. Studies by Popham (2011) and Wiggins (1998) have found that short answer questions encourage students to engage in critical thinking and demonstrate their understanding in meaningful ways. Furthermore, short answer questions can provide valuable insights into students' thought processes and misconceptions, informing instructional decisions and curriculum revisions (Sadler, 2005). The posttest was designed to mirror the pretest. The use of pretest short answer questions that mirror posttest questions offer valuable insights into students' learning progression and retention of knowledge over time (Guskey, 2010; Pellegrino, Chudowsky, & Glaser, 2001). This approach ensures a direct comparison between students' initial understanding, as measured by the pretest, and their subsequent comprehension, as assessed by the posttest (Brookhart & Nitko, 2015). Rubrics was developed and used for scoring. The scores recorded from the pretest and posttest were analysed with the aim of finding out the effects of teaching intervention using TMHCC on students' conceptions of direct current electricity.

Qualitative data were collected through a focused group interview to obtain a comprehensive understanding of the intervention's impact. Focused group interviews allow researchers to identify unanticipated effects or unintended consequences of the

intervention (Miles, Huberman, & Saldaña, 2014). Participants may reveal insights into aspects of the intervention that were particularly effective or challenging, as well as any unexpected outcomes that emerged during the implementation process. An interview guide was developed and used for the interview. The interview was carried out after the end of the last lesson. The responses from the interviews were analysed and compared with the test data in order to draw more accurate inferences about the students under study. The four groups (focused group) created during the intervention were interviewed with each group comprising ten students. Effort was made to ensure group members had mixed abilities and also balance gender representation. Students were interviewed for ten to fifteen minutes. All the interviews were recorded with the consent of students and transcribed.

Field observations was done from which field notes were made during and after the classes. Notes on what students were saying or doing during the class were recorded. The researcher highlighted what he thought was important, such as individual and group activities, responses, feedback on the status of students' conception, and feedback on the effectiveness of the instruction as a whole. Any theories that might have developed while observing a student or a group of students were recorded.

3.5 Validity and Reliability of Research Instruments

According to Cohen et al. (2018), validity is the degree to which a research instrument measures what it was intended to measure. The face validity and content validity of tests were established by having their format and appropriateness critiqued by two experienced physics teachers. Instructional objectives following the physics syllabus were considered in designing the tests in order to improve the content validity of the instrument. Great care was taken to ensure that all the aspects were represented. The

tests were field tested after it was modified from expert advice. The test was administered to Form 2 Agric 2 students to determine its reliability. Forty-two (42) Form two students took part in the test and it took them approximately 15 minutes to complete each test. The test-retest reliability was used to determine the reliability. After conducting a test-retest analysis, a Pearson correlation coefficient of $r = 0.85$ was obtained. This indicates a strong positive correlation between the measurements obtained at the two time points, suggesting high stability and consistency of the test scores over time.

3.6 Data Collection Procedure

Permission was sought from the Headmistress of Winneba Senior High School to undertake the study. The researcher administered a twenty minutes pre-test to the students to assess their knowledge before the intervention. This was followed by intervention using the Teaching Model for Hot Conceptual Change which took an hour. Afterwards, a twenty minutes post-test was administered immediately after the intervention to students to determine students' performance after the intervention. For every lesson, the data collection order indicated in Figure 4 was followed. The intervention took place within a period of two weeks.

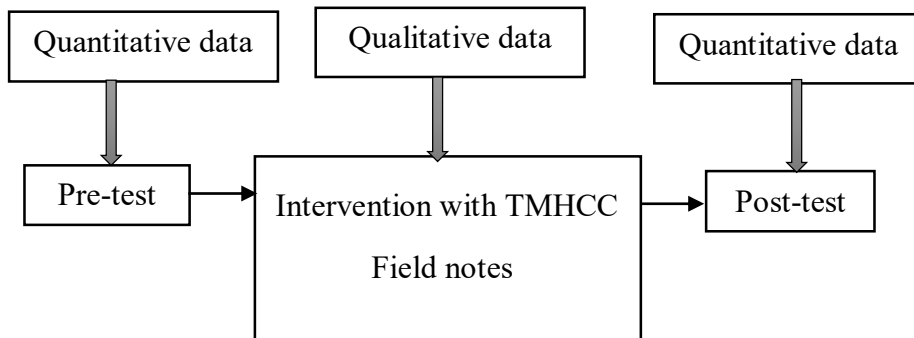

Figure 4: Data Collection Procedure

3.6.1 Report on teaching intervention using TMHCC

This part is dedicated to reporting how the TMHCC was implemented in the six lessons.

3.6.1.1 Report on teaching intervention Lesson 1

Topic: Electrical current

Duration: 2 hours

Specific Objectives:



By the end of the lesson students will be able to:

1. state the definition of current in their own words.
2. explain the terms conventional current and electron flow.
3. explain the term short circuit.
4. recall and use the relationship, $\text{charge} = \text{current} \times \text{time}$ to solve related problems
5. use the ammeter to measure the current in an electric circuit.

The researcher started the lesson by sharing the lesson objectives with students. The researcher informed the students that by the end of the lesson, they would be able to use the ammeter to measure current in a circuit, as a way to motivate students to learn

the concept of current. The researcher then elicited preconceptions by asking students to answer the probing questions which double as the pre-intervention test (refer to Appendix A). The researcher took the answer sheets after the allocated time had elapsed and called a few students to share their responses to the questions. The researcher praised students for their effort, examined students' responses and noted those in conflict with the scientific knowledge. The researcher put students into groups and then created a cognitive conflict in the student's minds by making students watch and manipulate a Phet DC circuit simulation on the concept. Students discussed the simulation in their respective groups after which the group leaders presented their findings. The researcher joined the discussions by wandering around the groups and sometimes asked questions to make things clearer to other students. In order to challenge metacognition, groups tried to defend their answer on the point of comprehensibility and plausibility while they were making explanations. Afterwards, the researcher discussed the concept of current with the students. The researcher explained that when a cell is connected to a circuit the electromotive force drives electrons from the cell which enter the wire and push nearby electrons. Similarly, the nearby electrons also push neighbouring electrons at the same time toward the other end of the wire. The entry of one electron pushes out one electron at the opposite end of the wire. This is because electrons are free to move between points of different electric potential. Electric current is produced as a result of the movement of the electrons. Electric current (I) is defined as the rate at which charge flows through a surface. Its unit is amperes (A). In an electrical circuit, the ammeter is connected in series to measure the current. Mathematically, $I = \frac{Q}{t}$ where Q is the charge, and t is time. **Conventional Current** assumes that current flows out of the positive terminal, through the circuit and into the negative terminal of the source. **Electron flow** describes

the actual flow of electrons in a circuit. In a circuit, electrons flow out of the negative terminal, through the circuit and into the positive terminal of the source. Similarly, charges are not used up in a circuit. The charges carry electrical energy from the cell to the other components in the circuit. The electrical energy is used by an electrical component such as the bulb to light up. Additionally, when current is made to traverse a path with negligible resistance, a large amount of current flows as a result which can be very dangerous. The circuit in this case is described as a short circuit.

The researcher asked students to perform the activity outlined in Section C of the Lesson 1 activity sheet and answered the questions that followed, by way of transferring the concept learnt to new situations. Afterwards, the researcher evaluated the lesson in two parts. Firstly, the researcher evaluated the learning outcome by making students answer the post-intervention test similar to the pre-intervention test found in Appendix 1. Afterwards, the researcher evaluated the instruction by asking students to verbally respond to the Part II questions at section D of the students' activity sheet. The researcher noted students' responses in the field notes and considered them when planning for the next lesson.

3.6.1.2 Report on teaching intervention Lesson 2

Topic: Potential difference (P.d) and Electromotive force (E.M.F)

Duration: 2 hours

Specific Objectives:

By the end of the lesson students will be able to:

1. define potential difference and E.M.F. in their own words

2. use the formula potential difference = energy/ charge to solve problems
3. use the voltmeter to measure the voltage across a component in a simple circuit.

The researcher commenced the lesson by sharing the lesson objectives with students. The researcher informed students that by the end of the lesson, they would be able to use the voltmeter to measure the potential difference across a component in a circuit as a way of motivating students to learn the concept.

The researcher elicited students' preconceptions on Potential difference and E.M.F. by asking students to answer pre-interventional test (refer to Appendix B) which acted as the probing questions. The researcher called a few students to share their responses to the questions. The researcher applauded students for their responses, identified the misconception students possess and also took cognisance of the fact that students have limited knowledge of this concept.

The researcher created cognitive conflict in the student's minds by making students to watch a video on the difference between E.M.F and P.d . Students were put into groups to discuss the video after which group leaders took turns to present their findings. Afterwards, the teacher discussed the concept of P.d. and E.M.F with the students. The opportunity was given for one group to critique or defend the response of the other based on comprehensibility and plausibility. The re is the electric current. At this point, one student asked, "But Sir, if $V=IR$, then that means that V and R are proportional thus would an increase not affect V ?". The researcher responded by indicating that this is a misconception many students possess. The magnitude of resistance is not affected by voltage and current but by the length of the conductor and cross-sectional area ($R = \rho l/A$). The researcher guided the students to transfer the new concept to different problems by asking students to perform the activity in Section C of the Lesson 4

Activity sheet. Afterwards, the researcher evaluated the learning outcome by making students answer the post-intervention test found in Appendix 4. After the time allocated for the test had elapsed, the researcher took students' answer sheets and then did a focused group interview with the students on the effectiveness of the instruction. Students' responses were audiotaped. The researcher considered students' responses when planning for the next lesson. The researcher made some notes in the field notes on some observations made during the course of the lesson.

3.6.1.3 Report on teaching intervention Lesson 3

Topic: Resistance

Duration: 2 hours

Specific Objectives:

By the end of the lesson students will be able to:

1. define electrical resistance in their own words.
2. apply the formulae for the effective resistance of several resistors in series and in parallel to solve related problems.
3. apply the relationship of the proportionality between resistance and the length and cross-sectional area of a wire to solve related problems.

The researcher shared the lesson objectives with students and told students that by the end of the lesson, they will be able to measure the resistance of a copper wire by using a multimeter. The researcher elicited students' preconceptions by asking students to answer the pre-intervention test found in Appendix C which acted as the probing questions. The researcher asked some students to share their responses.

The researcher applauded students for their response and then examined students' responses, and identified those in conflict with the scientific knowledge. The researcher then created a cognitive conflict in the student's mind by making students perform an activity in Section B of the Lesson 3 Activity sheet. The activity was carried out in groups and group leaders took turns and presented their findings.

The researcher then introduced the concept of resistance to the students. The researcher informed students that electrical resistance is the opposition to the flow of current (charges) in a material. The resistance of a piece of cylindrical wire R is related to its length l , cross sectional area A and its resistivity, ρ (each type of material has its own resistivity).

Mathematically,

$$R = \frac{\rho l}{A}$$

$$\text{Also, } A = \pi r^2 = \pi \left(\frac{d}{2}\right)^2 = \frac{\pi d^2}{4}$$

where r is the radius of the cylindrical wire, d is the diameter of the cylindrical wire.

The factors that affect the resistance of a conductor are the length l of the conductor, cross-sectional area A of the conductor, resistivity, ρ of the conductor, and temperature.

The researcher made students to answer the questions in Section C of Lesson 3 Activity sheet as a way of transferring the concept to solve different problems. Afterwards, the researcher evaluated the lesson. Firstly, the researcher evaluated the learning outcome by making students answer the post-intervention test similar to the pre-intervention test found in Appendix 3. Afterwards, the researcher evaluated the instruction by asking students to verbally respond to the Part II questions at section D of the students' activity sheet. The researcher noted students' responses in the field notes and considered them when planning for the next lesson.

3.6.1.4 Report on teaching intervention Lesson 4

Topic: Ohm's Law

Duration: 2 hours

Specific Objectives:

By the end of the lesson students will be able to;

1. state Ohm's law in their own words.
2. perform an experiment to verify Ohm's law.
3. use the formula $V=IR$ to solve problems.

The researcher started the lesson by sharing the lesson objectives with students. The researcher informed the students that by the end of the lesson, they would be able to determine the relationship between voltage, current and resistance as well as perform a simple experiment to verify Ohm's law as a way of motivating students to the learning context. The researcher elicited students' ideas and preconceptions by asking students to answer the pre-intervention test found in Appendix E which acted as the probing questions. After a while, the researcher called some students to share their responses with the class. Students started to critique others' statements. The researcher summarised responses on the board and took cognisance of those in conflict with scientific.

The researcher commended students for their effort in creating an effective discussion atmosphere. The teacher then created a cognitive conflict in the student's minds by making students manipulate the Phet Interactive simulation on Ohm's law and then discuss their observations in their respective groups. Afterwards, group leaders took turns and presented their findings. Group 5 leader started by saying that increasing the voltage of the power source saw an increase in the current and not the resistance. Again,

when only the resistance knob was moved up, the current decreased but the voltage of the battery remained the same. The other group's leaders also gave a similar response. At this point, the researcher introduced the scientific concept by discussing the concept of Ohm's law with the students. The researcher guided the students to define ohms in their own words by saying that, Ohm's law states that at constant temperature the current passing through a wire is directly proportional to the potential difference between the ends of the wire. Mathematically, the law is given as $V \propto I$, $V=IR$ where R is the constant of proportionality and is called electrical resistance, V is the potential difference across the conductor, and I is the electric current. At this point, one student asked, "But Sir, if $V=IR$, then that means that V and R are proportional thus would an increase not affect V ?". The researcher responded by indicating that this is a misconception many students possess. The magnitude of resistance is not affected by voltage and current but by the length of the conductor and cross-sectional area ($R = \rho l/A$). The researcher guided the students to transfer the new concept to different problems by asking students to perform the activity in Section C of the Lesson 4 Activity sheet. Afterwards, the researcher evaluated the learning outcome by making students answer the post-intervention test found in Appendix 4. After the time allocated for the test had elapsed, the researcher took students' answer sheets and then did a focused group interview with the students on the effectiveness of the instruction. Students' responses were audiotaped. The researcher considered students' responses when planning for the next lesson. The researcher made some notes in the field notes on some observations made during the course of the lesson.

3.6.1.5 Report on teaching intervention Lesson 5

Topic: Series connection of electrical components

Duration: 2 hours

Previous Knowledge: Students can connect electrical components in series.

Specific Objectives:

By the end of the lesson students will be able to:

1. explain that two or more identical bulbs connected in series to a dry cell produce a dimmer light than one of them connected to the same.
2. state that the current at every point in a series circuit is the same and apply the principle to new situations or to solve related problems.
3. state that the sum of the potential differences in a series circuit is equal to the potential difference across the whole circuit and apply the principle to new situations or to solve related problems.
4. recall and apply the relevant relationships, including $V = IR$ and those for current, potential differences and resistors in series, in calculations involving a whole circuit.

The researcher shared the lesson objectives with students as a way to motivate them to the learning context. The researcher elicited students' ideas and preconceptions using the pre-intervention test found in Appendix E as the probing questions. Afterwards, the researcher asked some students to share their responses with the class.

The researcher applauded students for their responses, summarised students' responses on board and took cognisance of those in conflict with the scientific knowledge. The researcher put students into groups and asked the groups to perform an activity as outlined in Section B of the Lesson 5 Activity sheet and answer the questions that

follow as a way of creating a cognitive conflict. Afterwards, group leaders took turns and presented their findings from the activity. Students were given the opportunity to critique the responses of others. After a while, the researcher introduced the concept of current in a series connection with the students. The researcher guided students to understand that in a series circuit, there is only one path for current flow. The current is the same at all points in a series circuit, $I = I_1 = I_2$. Again, the potential difference across each resistor in a series circuit is different and based on their individual resistances. The sum of the potential differences across the resistors gives the E.M.F. of the cell. $V = V_1 + V_2$. The overall E.M.F. (E) of the battery is the algebraic sum of all individual cells connected in series. Mathematically, $E = E_1 + E_2$. In a series of three cells with one cell wrongly connected, the effective E.M.F. is expressed as

$E = E_1 - E_2 + E_3$, where E_2 is the cell wrongly connected (wrong order). Furthermore, in a simple series circuit, the effective resistance is given by, $R = R_1 + R_2$. When two or more identical bulbs connected in series to a dry cell produce a dimmer light than one of them connected to the same source because the source voltage will be shared among the bulbs. When one of the bulbs is unscrewed, all other bulbs will go off because the circuit will be opened.

The researcher asked students to answer the question outlined in Section C of the Lesson 5 Activity sheet as a way of helping the students to transfer the concept learnt to other situations.

Afterwards, the researcher evaluated the lesson. Firstly, the researcher evaluated the learning outcome by making students answer the post-intervention test found in Appendix 5. Then the researcher evaluated the instruction by asking students to verbally respond to the Part II questions at section D of the students' activity sheet. The

researcher noted students' responses in the field notes and considered them when planning for the next lesson.

3.6.1.6 Report on teaching intervention Lesson 6

Topic: Parallel connection of electrical components

Duration: 2 hours

Specific Objectives:

By the end of the lesson students will be able to:

1. state that the current from the source is the sum of the currents in the separate branches of a parallel circuit and apply the principle to new situations or to solve related problems.
2. state that the potential difference across the separate branches of a parallel circuit is the same and apply the principle to new situations or to solve related problems.
3. explain why similar bulbs connected in parallel to a cell produce the same brightness but dissimilar bulbs produce varying brightness depending on their resistances.
4. state the advantages of connecting electrical components in parallel.

The researcher commenced the lesson by motivating students to the learning context. The researcher shared the lesson objectives with the students and informed them that by the end of the lesson, they will be able to explain why one bulb in a Christmas tree light die, while the other lights continue to shine.

The researcher continued the lesson by eliciting students' ideas and preconceptions by using the pre-intervention test in Appendix F as the probing questions. The researcher called some students to share their responses. The researcher applauded students for their responses, summarised students' responses on the board and paid attention to those that were at odds with the body of scientific knowledge. The researcher put students into groups and asked them to perform the activity outlined in Section B of the Lesson 6 Activity Sheet as a way of creating a cognitive conflict in the student's minds. After the activity, group leaders took turns presenting their findings to the hearing of the whole class. An opportunity was given to students to defend and critique others' responses. The researcher guided students to understand that for a simple parallel circuit, the potential difference across each resistor is the same and is equal to the E.M.F. of the cell. That is, $V = V_1 = V_2$. In a parallel circuit, there is more than one loop or pathway so charge flow gets split up or recombined at junction points. Therefore, the current is not the same at every point in the circuit, $I = I_1 + I_2$. The effective resistance in a parallel circuit is given by $\frac{1}{R} = \frac{1}{R_1} + \frac{1}{R_2}$ where R is effective resistance. Similar bulbs connected in parallel to a cell produce the same brightness but dissimilar bulbs produce varying brightness depending on their resistances. When one of the bulbs is disconnected in a sub-circuit, others in the other sub-circuits continue to glow.

Afterwards, the researcher asked students to solve the questions in Section C of the Lesson 6 Activity sheet as a way to help students to transfer new the concept to different situations. Then the researcher evaluated the lesson. Firstly, the researcher evaluated the learning outcome by making students answer the post-intervention test found in Appendix 6. Afterwards, the researcher evaluated the instruction by asking students to

verbally respond to the Part II questions in section D of the students' activity sheet. The researcher noted students' responses in the field notes.

3.7 Data analysis

Quantitative and qualitative data were presented and analysed using quantitative and qualitative data analysis approaches respectively. Students' responses for the pre-intervention test and post-intervention test were rated using a three-point scale (1 – incorrect, 2- partially correct, 3- correct) and entered in SPSS version 20. Students' responses that were difficult to understand or responses that had no relation to the questions or no responses at all were rated incorrect. Students' responses that belong to this category were full of misconceptions. Again, responses that were correct but incomplete or with key items or steps missing were rated as partially correct. Lastly, scientifically acceptable responses, with all key items or steps present were ascribed correct. The Wilcoxon signed-rank test was performed to determine if there was a significant effect of the teaching intervention on students' conceptual understanding of some selected topics in current electricity. To quantify the effect that took place after the intervention, the effect size was calculated. The effect size was computed using Rosenthal (1991) formula, $r = \frac{Z}{\sqrt{N}}$, as cited in Field (2018). The researcher indicated that Z is the Wilcoxon signed rank test statistics and N is the total number of observations ($40 \times 2 = 80$). Similarly, Cohen (1988) as cited in Field (2018) was used for interpreting effect size. According to Cohen, an effect size of 0.10 - 0.20 is small, 0.30 - 0.40 is medium, and 0.50 and above is large.

Frequencies and percentages of students' responses were presented. The qualitative data were analysed using thematic content analysis.

These additional sources of evidence provided were used for triangulation, not only confirming the validity of the data obtained from the tests but also to reveal possible factors contributing to the observed differences. Table 1 shows how the analysis was done.

Table 1: Data Analysis plan

Research Question	Instrument	Analysis
1. What is the effect of the Teaching Model for Hot Conceptual change on students' conceptual understanding of selected topics in current electricity?	Electricity Concept Test (Pre-test and Post-test), Field notes, Interview	Wilcoxon signed rank test, Effect Size, Thematic analysis
2. What is the performance of students in the selected topics taught through the conceptual change approach?	Electricity Concept Test (Pre-test and Post-test), Field notes, Interview, Activity	Frequency, Percentage, Thematic analysis
3. What conceptual changes occurred during the use of the conceptual change approach to teach selected topics in physics?	Electricity Concept Test (Pre-test and Post-test), Field notes, Interview, Activity sheet	Frequency, Thematic analysis

3.8 Ethical Consideration

The research addressed all ethical concerns which include informed consent, anonymity, and confidentiality. Permission was obtained from the Head of the school to do the study. The researcher obtained informed verbal consent from the students before commencement. In the study, the respondents' right to anonymity was also heavily considered. For identifying reasons in this study, fictional names that could not

be linked to the participants were utilised. The ethical requirement of anonymity was upheld by not collecting respondents' names or any other personally identifying information. On the issue of confidentiality, participants were told that their responses would be kept confidential and that no one known to them would have access to the information provided and none of the respondents' names was recorded in the study.

3.9 Summary

One intact Form 2 class (2Ag. 1) considered a low-performing science class was used as the sample group for this study. The researcher used TMHCC as an intervention to improve students' performance. This study followed a mixed methodology which required both quantitative and qualitative data. Data were taken using the pre-test and post-test, semi-structured interview, field observation, and activity sheets.



CHAPTER FOUR

RESULTS AND DISCUSSION

4.0 Overview

This chapter deals with the presentation and analysis of data gathered from the test (pretest and posttest), the focused group interview conducted and field notes taken. The data gathered were analysed and discussed according to the research questions. In the second part, the data was analysed and presented according to the research questions. Following this is the discussion of the results and finally the chapter summary.

4.1 Analysis of Data from the Three Research Instruments

In this section, the data generated from the three instruments were analysed. Discussions of the findings were conducted based on the research questions, and relevant literature was used to support the findings.

4.1.1 Analysis with respect to research question one

RQ1: What is the effect of the Teaching Model for Hot Conceptual Change on students' conceptual understanding of selected topics in current electricity?

4.1.1.1 Presentation of test data

Table 2 shows the results of the Wilcoxon signed rank test for the pre-intervention test and post-intervention test in lesson 1 and the corresponding effect sizes.

Table 2: Results of Wilcoxon Signed Rank Test and Effect Size for the Pretest and Posttest in Lesson 1

Item	Pretest/ Posttest	N	Mdn	Z	r
1. Definition of electric current	Pretest	40	1.0	-5.62	0.63
	Posttest	40	3.0		
2. Difference between conventional current and electron flow	Pretest	40	1.0	-5.50	0.61
	Posttest	40	3.0		
3. Solving problems using $Q = It$	Pretest	40	1.0	-5.56	0.62
	Posttest	40	3.0		
4. Explanation of the non-consummation of electric charges in the bulb.	Pretest	40	1.0	-5.72	0.64
	Posttest	40	3.0		
5. Description of the connection of an ammeter	Pretest	40	1.0	-5.74	0.64
	Posttest	40	3.0		
6. Explanation of the term short circuit	Pretest	40	1.0	-5.73	0.64
	Posttest	40	3.0		

Note. $p < 0.05$, N= number of respondents, Mdn = Median, r = effect size,

Z = Wilcoxon signed rank test statistics

Source: *Field Survey, 2022*

From Table 2, Wilcoxon signed rank test indicated that students' performance the definition of electric current in the posttest was higher ($Mdn = 3.0$) than the pretest ($Mdn = 1.0$), $z = -5.622$, $p < .001$, with a large effect size ($r = .63$). Similarly, students' were able to differentiate between conventional current and electron flow in the posttest ($Mdn = 3.0$) than in the pretested ($Mdn = 1.0$), $z = -5.500$, $p < .001$, with a large effect size ($r = 0.61$). Furthermore, the Wilcoxon Signed rank test revealed that students' conceptual understanding in the application of the current formula $I = Q/t$ to solve problems in the posttest was higher ($Mdn = 3.0$) than the pretest ($Mdn = 1.0$), $z = -5.56$, $p < .001$, with a large effect size ($r = .62$). For the explanation of the non-

consummation of electric charges in a bulb, students were better in the explanation in the posttest ($Mdn = 3.0$) than the pretest ($Mdn = 1.0$), $z = -5.72$, $p < .001$, with a large effect size ($r = .64$). Also, the performance of students in the description of the connection of an ammeter with aid of a diagram was better in the posttest ($Mdn = 3.0$) than in the pretest ($Mdn = 1.0$), $z = -5.74$, $p < .001$, with a large effect size ($r = .64$). Similarly, students' explanation of short circuits was better in the explanation in posttest ($Mdn = 3.0$) than in the pretest ($Mdn = 1.0$), $z = -5.73$, $p < .001$, with a large effect size ($r = .64$).

Table 3 shows the results of the Wilcoxon signed rank test for the pre-intervention test and post-intervention test in lesson 2 and the corresponding effect sizes.

Table 3: Results of Wilcoxon Signed Rank Test and Effect Size for the Pretest and Posttest in Lesson 2

Concept	Pretest/ Post-test	N	Mdn	Z	r
1. Explanation of Potential difference and E.M.F	Pretest	40	1	-5.55	0.62
	Posttest	40	3		
2. Explanation of the origin of the charges that flow in the circuit	Pretest	40	1	-5.75	0.64
	Posttest	40	3		
3. Solving problems with the formula $V = \text{Energy}/ \text{charge}$	Pretest	40	1	-5.81	0.65
	Posttest	40	3		
4. Description of how to connect a voltmeter in a circuit to measure the voltage	Pretest	40	1	-5.84	0.65
	Posttest	40	3		

Note. $p < 0.05$, N= number of respondents, Mdn = Median, r = effect size,

Z = Wilcoxon signed rank test statistics

Source: *Field Survey, 2022*

From Table 3, Wilcoxon Signed rank test indicated that students' ability in the differentiating between Potential difference and E.M.F in the posttest were better ($Mdn = 3.0$) than the pretest ($Mdn = 1.0$), $z = -5.55$, $p < .001$, with a large effect size ($r = .62$). Similarly, the explanation of the origin of the charges that flow in the circuit by students was better in the posttest ($Mdn = 3.0$) than in the pretested ($Mdn = 1.0$), $z = -5.75$, $p < .001$, with a large effect size ($r = .64$). Furthermore, the Wilcoxon Signed rank test also indicated that students' performance in solving problems with the formula $V = \text{Energy} / \text{charge}$ in the posttest was higher ($Mdn = 3.0$) than in the pretest ($Mdn = 1.0$), $z = -5.81$, $p < .001$, with a large effect size ($r = .65$). For the description of how to connect a voltmeter in a circuit to measure the voltage, students were better in the description in the posttest ($Mdn = 3.0$) than in the pretest ($Mdn = 1.0$), $z = -5.84$, $p < .001$, with a large effect size ($r = .65$).

Table 4 shows the results of the Wilcoxon signed rank test for the pre-intervention test and post-intervention test in lesson 3 and the corresponding effect sizes.

Table 4: Results of Wilcoxon Signed Rank Test and Effect Size for the Pretest and Posttest in Lesson 3

Concept	Pretest/ Post-test	N	Mdn	Z	r
1. Definition of electrical resistance	Pretest	40	1	-5.42	0.61
	Posttest	40	3		
2. Explanation of the effect of length on the resistance of the metallic conductor	Pretest	40	1	-5.58	0.62
	Posttest	40	3		
3. Explanation of the effect of cross-sectional area on the resistance of the metallic conductor	Pretest	40	1	-5.73	0.64
	Posttest	40	3		
4. Explanation of the effect of temperature on the resistance of a metallic conductor	Pretest	40	1	-5.57	0.62
	Posttest	40	3		

Note. $P < 0.05$, N= number of respondents, Mdn = Median, r = effect size,

Z = Wilcoxon signed rank test statistics

Source: *Field Survey, 2022*

From Table 4, Wilcoxon Signed rank test indicated that students' performances in the definition of electrical resistance in the posttest were better ($Mdn = 3.0$) than the pretest ($Mdn = 1.0$), $z = -5.55$, $p < .001$, with a large effect size ($r = .62$). In the same way, the explanation of the effect of length on the resistance of the metallic conductor by students was better in the posttest ($Mdn = 3.0$) than in the pretested ($Mdn = 1.0$, $z = -5.75$, $p < .001$), with a large effect size ($r = .64$). Additionally, the Wilcoxon Signed rank test also indicated that students' performance in the explanation of the effect of cross-sectional area on the resistance of the metallic conductor in the posttest was higher ($Mdn = 3.0$) than the pretest ($Mdn = 1.0$), $z = -5.84$, $p < .001$, with a large effect size ($r = .65$). Again, students' performances in the explanation of the effect of temperature on the resistance of a metallic conductor were better in the description in the posttest ($Mdn = 3.0$) than in the pretest ($Mdn = 1.0$), $z = -5.57$, $p < .001$, with a large effect ($r = .62$).

Table 5 shows the results of the Wilcoxon signed rank test for the pretest and posttest in lesson 4 and the corresponding effect sizes.

Table 5: Results of Wilcoxon Signed Rank Test and Effect Size for the Pretest and Posttest in Lesson 4

Concept	Pretest/ Post-test	N	Mdn	Z	r
1. Stating Ohm's Law	Pretest	40	1	-5.54	0.62
	Posttest	40	3		
2. Explanation of the effect of changing (increasing) voltage across the resistor on the resistance of the resistor	Pretest	40	1	-6.25	0.70
	Posttest	40	3		
3. Explanation of the effect of changing the resistance in a circuit on the voltage from the power source	Pretest	40	1	-5.81	0.64
	Posttest	40	3		
4. Explanation of the effect of increasing the E.M.F in a circuit on the current	Pretest	40	2	-5.49	0.61
	Posttest	40	3		

Note. $p < 0.05$, N= number of respondents, Mdn = Median, r = effect size,

Z = Wilcoxon signed rank test statistics

Source: *Field Survey, 2022*

From Table 5, Wilcoxon signed rank test indicated that students' performance stating Ohm's Law in the posttest was higher ($Mdn = 3.0$) than in the pretest ($Mdn = 1.0$, $z = -5.54$, $p < .001$), with a large effect size ($r = .62$). Similarly, the explanation of the effect of changing the voltage across the resistor on the resistance of the resistor by students was better in the posttest ($Mdn = 3.0$) than in the pretested ($Mdn = 1.0$, $z = -6.25$, $p < .001$), with a large effect size ($r = .70$). Furthermore, the Wilcoxon Signed rank test also

indicated that students' performance in the explanation of the effect of changing the resistance in a circuit on the voltage from the power source in the posttest was higher ($Mdn = 3.0$) than the pretest ($Mdn = 1.0, z = -5.81, p < .001$), with a large effect size ($r = .65$). Again, students' performances in explaining the effect of increasing the E.M.F in a circuit on the current were higher in the posttest ($Mdn = 3.0$) than in the pretest ($Mdn = 2.0, z = -5.49, p < .001$), with a large effect size ($r = .61$).

Table 6 shows the results of the Wilcoxon signed rank test for the pretest and posttest in lesson 5 and the corresponding effect sizes.

Table 6: Results of Wilcoxon Signed Rank Test and Effect Size for the Pretest and Posttest in Lesson 5

Concept	Pretest/ Post-test	N	Mdn	Z	r
1. Calculating total E.M.F. in a series circuit	Pretest	40	1	-5.40	0.60
	Posttest	40	3		
2. Calculating the effective resistance in a series circuit	Pretest	40	1	-5.44	0.61
	Posttest	40	3		
3. Finding the current in a series circuit	Pretest	40	1	-5.25	0.59
	Posttest	40	3		
4. Description of the brightness of bulbs in a series circuit	Pretest	40	1	-5.67	0.63
	Posttest	40	3		

Note. $p < 0.05$, N= number of respondents, Mdn = Median, r = effect size,

Z = Wilcoxon signed rank test statistics

Source: *Field Survey, 2022*

From Table 6, Wilcoxon Signed rank test revealed that students' performances in calculating total E.M.F. in a series circuit in the posttest were better ($Mdn = 3.0$) than the pretest ($Mdn = 1.0, z = -5.40, p < .001$), with a large effect size ($r = .60$). Again, in the calculation of the effective resistance in a series circuit, students' performance was

better in the posttest ($Mdn = 3.0$) than in the pretested ($Mdn = 1.0$), $z = -5.44$, $p < .001$, with a large effect size ($r = .61$). Furthermore, the Wilcoxon signed rank test also indicated that students' performance in finding the current in a series circuit in the posttest was higher ($Mdn = 3.0$) than the pretest ($Mdn = 1.0$), $z = -5.25$, $p < .001$, with a large effect size ($r = .59$). Additionally, students' performances in the description of the brightness of bulbs in a series circuit were better in the description in the posttest ($Mdn = 3.0$) than in the pretest ($Mdn = 1.0$), $z = -5.67$, $p < .001$, with a large effect size ($r = .63$).

Table 7 shows the results of the Wilcoxon signed rank test for the pretest and posttest in lesson 6 and the corresponding effect sizes.



Table 7: Results of Wilcoxon Signed Rank Test and Effect Size for the Pretest and Posttest in Lesson 6

Concept	Pretest/ Post-test	N	Mdn	Z	r
1. Finding the potential difference in across electrical components in a parallel circuit	Pretest	40	1	-5.36	0.60
	Posttest	40	3		
2. Calculating the effective resistance in a parallel circuit	Pretest	40	1	-5.41	0.60
	Posttest	40	3		
3. Finding the current in all branches of a parallel circuit	Pretest	40	1	-5.98	0.67
	Posttest	40	3		
4. Explanation to why similar bulbs produce similar brightness but dissimilar bulbs produce varying brightness in parallel circuit	Pretest	40	1	-5.50	0.61
	Posttest	40	3		

Note. $p < 0.05$, N= number of respondents, Mdn = Median, r = effect size,

Z = Wilcoxon signed rank test statistics

Source: *Field Survey, 2022*

From Table 7, the Wilcoxon Signed rank test indicated that students' performances in finding the potential difference across electrical components in a parallel circuit in the posttest were higher ($Mdn = 3.0$) than the pretest ($Mdn = 1.0$), $z = -5.36$, $p < .001$, with a large effect size ($r = .60$). Again, students' performances in calculating the effective resistance in a parallel circuit was higher in the posttest ($Mdn = 3.0$) than in the pretested ($Mdn = 1.0$), $z = -5.41$, $p < .001$, with a large effect size ($r = .60$). Furthermore, the Wilcoxon Signed rank test also indicated that students' performance in calculating the current all branches of a parallel circuit in the posttest was higher ($Mdn = 3.0$) than the pretest ($Mdn = 1.0$), $z = -5.98$, $p < .001$, with a large effect size ($r = .67$). Similarly, students' performances in the explanation to why similar bulbs

produce similar brightness but dissimilar bulbs produce varying brightness in parallel circuit were better in the posttest ($Mdn = 3.0$) than in the pretest ($Mdn = 1.0$), $z = -5.50$, $p < .001$, with a large effect size ($r = .61$).

4.1.1.2 Presentation of semi-structured interview data

When students were asked to indicate their general feelings on the teaching strategy (TMHCC) used in teaching the electricity concept, the following are some of the responses that emerged:

G1S1: *The group work helped me to better understand the topic. The critiquing and defending part really forced me to think and also showed me areas where I had issues.*

G2S3: *Very nice. The use of the simulations as well as the electricity kits made the lesson very practical. There was a lot of encouragement from my group members to learn the manipulation of the simulation and make electrical connections with electricity kits.*

G3S8: *Asking students about the strengths and weaknesses of the instruction at the end of every lesson and making the necessary changes in the one that follows was something I really liked.*

G4S5: *It has helped me to change my mentality that physics is very difficult. I have seen that if you understand, things look quite simpler. It has increased my confidence level in problem-solving.*

From the responses, it is evident that most students mentioned key features of the TMHCC that have influenced their conceptual understanding of the electricity concept taught. Students mentioned group work or argumentation, metacognition, use of

multiple representations (simulation and electricity kit), motivation and evaluation of the instruction with students. Similarly, the students revealed that they enjoyed the lessons and the lessons have improved understanding and increased their confidence in problem-solving.

4.1.1.3 Presentation of field notes data

Evidence from the field notes showed that students were highly actively engaged, motivated, enjoyed working in groups and gradually showed improvements in their response to questions and their skills in general. At the start of the lesson, few students volunteered to manipulate the Phet simulation on the laptop assigned to the group. Similarly, students showed little confidence when working with the electricity kits. Students' lack of voluntarism and self-confidence in working with the Phet simulation and the electricity kit respectively was attributed to the fact students had little to no experience working with them. It was observed that the situation changed as the lesson progressed. This might be attributed to the statement the researcher made. That is, group membership will be maintained in all the lessons, however, the group leadership would be rotated on a daily basis with all students having equal opportunity to be selected. After this statement, students were more zealous to learn to work with the materials available and prepare themselves against their possible call-ups for group leadership. Students enjoyed working in groups, sharing ideas and critiquing other groups' responses during the instruction. Students' critiquing skills improved as the lessons progressed. From the students' activity sheet, it was observed that majority of the students were able to transfer the concept learnt to new problems.

Discussion of Results for Research Question 1

The Wilcoxon signed rank test indicated that there was a statistically significant difference in students' performance in the pre-intervention test and post-intervention test for all six lessons (Table 2, Table 3, Table 4, Table 5, Table 6 and Table 7). For the six lessons, the effect size was found to be large. The large effect sizes obtained for each lesson signify not only the statistical significance but also the practical significance of the TMHCC in fostering meaningful learning outcomes in the selected topics in current electricity. The finding supports the conclusions of several studies (Baser & Geban, 2007; Ozkan & Selçuk, 2012; Phromsena et al., 2019). The researchers posited that the conceptual change teaching strategy is effective in raising students' performance by addressing their misconceptions. It was clear from the focused group interview responses, that majority of students cited important TMHCC features that were fascinating to them and helpful in reshaping their thinking. The use of numerous representations (such as simulations and electrical kits), group work or argumentation, metacognition, motivation, and evaluation of the lesson with students all cited by the students to have helped in improving students' comprehension and boosted their confidence in problem-solving. The findings confirmed the study by Muhammad, Bakar, Mijinyawa and Halabi (2015) who posited that motivation has a positive effect on students' academic performance. Similarly, Wang, Chen, and Yen (2021) work is in congruence with the findings of this study by revealing that students' conceptual understanding, science process skills, confidence judgment, and inquiry performance are improved as a result of metacognition. Lastly, the findings from the field notes are almost the same as the interview data and together validate the test results. This clearly indicates that the TMHCC has had an effect on students' academic performance by way of improving students' understanding, manipulation and

connection of circuit components skills, critiquing and communication skills and finally changing students' attitudes towards physics.

4.1.2. Analysis with Respect to Research Question Two

RQ2: What is the performance of students in the selected topics taught through the Teaching Model for Hot Conceptual change?

Students' responses in the pretest and posttest were analysed topic-wise to determine their performance. The performance of students was determined in terms of what students were able to do correctly, partially correct, and incorrectly in the concepts taught in all six lessons before and after the intervention. Similarly, students' response in the semi-structured interview and field notes are also presented.

4.1.2.1 Presentation of test data

Table 8 shows the performance of students in Electric current in the pre-interventional test and post-interventional test for lesson 1.

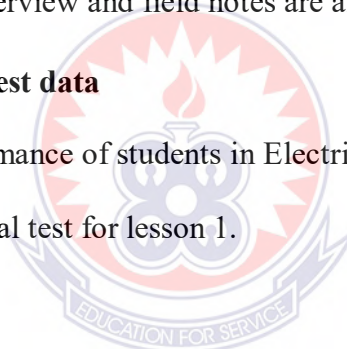

Table 8: Performance of students in Electrical Current

Item	Pretest			Posttest		
	IC	PC	C	IC	PC	C
1. Definition of electric current	25 (62.5%)	14 (35.0%)	1 (2.5%)	0 (0.0%)	3 (7.5%)	37 (92.5%)
2. Difference between conventional current and electron flow	31 (77.5%)	9 (22.5%)	0 (0.0%)	3 (7.5%)	3 (7.5%)	34 (85.0%)
3. Solving problem using $Q = It$	32 (80.0%)	6 (15.0%)	2 (5.0%)	1 (2.5%)	5 (12.5%)	34 (85.0%)
4. Explanation of the non-consummation of electric charges in bulb	34 (85.5%)	5 (12.5%)	1 (2.5%)	0 (0.0%)	6 (15.0%)	34.0 (85.0%)
5. Connection of an ammeter in a circuit to measure the current	35 (87.5%)	3 (7.5%)	2 (5.0%)	0 (0.0%)	13 (32.5%)	27 (67.5%)
6. Explanation of a short circuit	33 (82.5%)	7 (17.5%)	0 (0.0%)	2 (5.0%)	1 (2.5%)	37 (92.5%)

Note. IC = Incorrect, PC = Partial correct, C = Correct

Source: *Field Survey, 2022*

The analysis of students' responses in the pre-intervention and post-intervention test taken during lesson one revealed that majority of students 37(92.5%) correctly defined current in the post-intervention test by indicating that electric current is the rate of flow of charges (electrons) in a conductor. However, 25(62.5%) of the students had the definition of electric current incorrect in the pre-intervention test by either not answering or defining current as a process by which electricity powers appliances. Similarly, a few students 14(35.0%) had an idea about the definition but replaced the movement of charges past a point in a circuit with the movement of electricity.

For the difference between conventional current and electron flow, majority of the students 34(85.0%) gave the correct response in the post-intervention test by indicating that conventional current deals with the flow of current out of the positive terminal, through the circuit and into the negative terminal of the source while electron flow describes the flow of electrons out of the negative terminal, through the circuit and into

the positive terminal of the source. In the pre-intervention test, while few students 9(22.5%) had the difference between conventional current and electron flow partially correct for failing to indicate the directions of the conventional current and electrons from the cell, majority of the students 31(77.5%) had it incorrect by mostly leaving the response blank.

When students were asked about the effect of tripling the charges in a circuit at a particular time on current, 32(80.0%) of the students had it incorrect by leaving the response blank or stating that there is no effect on the current in the pre-intervention. Similarly, few students 6(15.0%) responded that tripling the charges increases the current but made no reference to the formula $Q=It$. However, majority of the students 34(85.0%) gave the correct response in the post-intervention test mentioning that since Q is directly to I according to the formula $Q=It$, increasing the charges makes the current increase.

Furthermore, when students were asked to explain what happens to the charges in a bulb, 34(85.5%) of students stated in the pre-intervention test that charges are consumed in a bulb which was incorrect. While a few students 5(12.5%) only responded that charges are not consumed in a bulb, only 1(2.5%) of the students went ahead and explained that the bulb makes use of the electrical energy carried by the charge. In the post-intervention test, majority of the students 34(85.0%) had the correct response by mentioning that the bulb makes use of the electrical energy carried by the charge therefore the charges are not consumed in a bulb.

When students were asked to describe with the aid of a diagram how an ammeter is connected in a circuit to measure the current, majority of the students 35(87.5%) mentioned that ammeters are connected in series in a circuit and drew an appropriate

circuit diagram to support the response in the post-intervention test. In the pre-intervention test, majority of the students 35(87.5%) were not able to describe how an ammeter is connected in a circuit to measure current. Few students 3(7.5%) indicated that the ammeter is connected in series but failed to support their responses with a diagram while few students 2(5.0%) explained and supported their responses with appropriate diagrams.

On the concept of short circuit, majority of the students 37(92.5%) were able to explain that a short circuit is a circuit where very large current flows as a result of traversing a path with very small or negligible resistance in the post-intervention test. In the pre-intervention test, while majority of the students 33(82.5%) gave the incorrect response by explaining short circuit as a circuit which is short, 7(17.5%) of the students explained that a short circuit is a circuit where current moves in a short path.

Table 9 shows the performance of students in Electromotive force (E.M.F.) and the Potential difference (P.d.) in the pre-interventional test and post-interventional test for lesson 2.

Table 9: Performance in Electromotive force and Potential difference

Item	Pretest			Posttest		
	IC	PC	C	IC	PC	C
1. Differentiating between Potential difference and E.M.F	25 (62.5%)	14 (35.0%)	1 (2.5%)	1 (2.5%)	7 (17.5%)	32 (80.0%)
2. Explaining the origin of the charges that flows in the circuit	32 (80.0%)	8 (20.0%)	0 (0.0%)	1 (2.5%)	2 (5.0%)	37 (92.5%)
3. Solving problem with the formula $V = \text{Energy}/\text{charge}$	36 (90.0%)	3 (7.5%)	1 (2.5%)	0 (0.0%)	5 (12.5%)	35 (87.5%)
4. Description of the connection of the voltmeter in a circuit to measure the voltage	34 (85.0%)	4 (10.0%)	2 (5.0%)	0 (0.0%)	2 (5.0%)	38 (85.0%)

Note. IC = Incorrect, PC = Partial correct, C = Correct

Source: *Field Survey, 2022*

The analysis of students' responses in the pre-intervention and post-intervention test taken during lesson 2 revealed that majority of the students 32(80.0%) gave the correct response in the post-intervention test. Students mentioned that the E.M.F. is present even when no current is drawn through the battery whereas P.d across the conductor is zero in the absence of current. Similarly, EMF does not depend on circuit resistance whereas P.d depends on the resistance between two points of measurement. On the contrary, majority of the students 25(62.5%) indicated in pre-intervention test that P.d and E.M.F are the same which was incorrect. Few students 14(35.0%) stated that P.d and E.M.F are not the same but failed to explain why they are not.

Again, concerning the origin of the charges that flow in the circuit, majority of the students 32(80.0%) indicated in the pre-intervention test that the charges originate from the cell. Again, 8(20.0%) of the students stated that the charges did not originate from the cell but failed to explain further. However, majority of the students 37(92.5%) gave the correct response in the post-intervention test by mentioning that the charges that move in the circuit are the free electrons in the conductors (wires).

On the calculation of the voltage using $v=E/Q$, only 1(2.5%) of the students quoted the formula, did the correct substitution and had the correct answer with its unit in the pre-intervention test. Few students 3(7.5%) quoted the right formula with wrong substitution, 36(90.0%) of the students had no idea about how to go about the calculations. However, 35(87.5%) did the correct calculations and attached the appropriate unit in the post-intervention test.

On the description of the connection of the voltmeter in a circuit to measure the voltage, majority of the students 38(85.0%) gave the correct description with the required diagram in the post-intervention test. Students mentioned that the voltmeter is connected across the component (in parallel) whose voltage is to be measured and then supported the response with a simple circuit diagram. On the contrary, majority of the students 34(85.0%) were not able to describe how a voltmeter is connected in a circuit to measure voltage in the pre-intervention test. Few of the students 4(10.0%) stated that the voltmeter is connected in parallel to the component whose voltage is to be determined but failed to support their responses with a diagram. While 2(5.0%) of students explained and supported their responses with appropriate diagram.

Table 10 shows the performance of students in Electrical resistance in the pre-interventional test and post-interventional test for lesson 3.

Table 10: Performance in Electrical Resistance

Concept	Pre-test			Post test		
	IC	PC	C	IC	PC	C
1. Definition of resistance	23 (57.5%)	13 (32.5%)	4 (10.0%)	0 (0.0%)	1 (2.5%)	39 (97.5%)
2. The effect of length on the resistance of metallic conductor	31 (77.5%)	8 (20.0%)	1 (2.5%)	1 (2.5%)	4 (10.0%)	35 (87.5%)
3. The effect of cross-sectional area on the resistance of metallic conductor	36 (90.0%)	3 (7.5%)	1 (2.5%)	1 (2.5%)	5 (12.5%)	34 (85.5%)
4. Explanation of how temperature affects the resistance of a metallic conductor	33 (82.5%)	7 (17.5%)	0 (0.0%)	2 (5.0%)	6 (15.0%)	32 (80.0%)

Note. IC = Incorrect, PC = Partial correct, C = Correct

Source: *Field Survey, 2022*

The analysis of students' responses in the pre-intervention and post-intervention tests taken during lesson 3 showed that minority of students 4(10.0%) gave the correct definition of electrical resistance as the opposition to the flow of electric current in the pre-intervention test. Few students 13(32.5%) gave the definition as the force that opposes the flow of electric current in a circuit while 23(57.5%) gave incorrect responses either by mentioning that resistance is the force that hinders electricity from flowing or leaving the response blank. However, in the post- intervention test, majority

of the students 39(97.5%) gave the correct response by defining electrical resistance as the opposition to the flow of electric current

On the effect of the length on the resistance of a metallic conductor, only 1(2.5%) of the students explained in the pre-intervention test that resistance and the length of the conductor are directly proportional and that increasing length also increases the resistance of the conductor. Similarly, few students 8(20.0%) mentioned that the length of the conductor affects the resistance but made no reference to the relation $r \propto l$. Majority of the students 31(77.5%) gave the incorrect response by either mentioning that the length of the conductor has no effect on the resistance or by leaving the response blank. However, in the posttest, majority of the students 35(87.5%) gave the correct response that resistance and the length of the conductor are directly proportional and that increasing length also increases the resistance of the conductor.

Regarding the effect of the cross-sectional area on the resistance of a metallic conductor, only 1(2.5%) of the students correctly explained in the pre-intervention test that resistance and the cross-sectional area of the conductor are inversely proportional and that increasing the cross-sectional area decreases the resistance of the conductor.

Similarly, few students 3(7.5%) mentioned that the cross-sectional area of the conductor affects the resistance but made no reference to the relation $r \propto \frac{1}{A}$. Majority of the students 31(77.5%) gave the incorrect response by either mentioning that the cross-sectional area of the conductor has no effect on the resistance or by leaving the response blank. However, in the post-intervention test, majority of the students 34(85.5%) gave the correct response that the resistance and the cross-sectional area of the conductor are inversely proportional and that increasing the cross-sectional area decreases the resistance of the conductor.

When students were asked to explain how temperature affects the resistance of a metallic conductor in the pre-intervention test, majority of the students 33(82.5%) responded incorrectly by indicating that temperature causes object to expand and that does not affect the resistance of the metallic conductor. Few students 7(17.5%) mentioned that the temperature does affect the resistance of the metallic conductor but failed to explain how the resistance is affected by the temperature. However, majority of the students 32(80.0%) in the post-intervention test explained that temperature increases the resistance of the metallic conductor due to increase in the collisions and vibrations of the electrons and atoms respectively. Similarly, few students 6(15.0%) mentioned in the post-intervention test that temperature affects the resistance of the metallic conductor but failed to explain further.

Table 11 shows the performance of students in Ohm's law in the pre-interventional test and post-interventional test for lesson 4.

Table 11: Performance in Ohm's law concept

Aspects	Pre-test			Post test		
	IC	PC	C	IC	PC	C
1. Stating Ohm's Law	24 (60.0%)	14 (35.0%)	2 (5.0%)	0 (0.0%)	4 (10.0%)	36 (90.0%)
2. Effect of increasing the E.M.F on the resistance of a metallic conductor	39 (97.5%)	0 (0.0%)	1 (2.5%)	0 (0.0%)	0 (0.0%)	40 (100.0%)
3. Effect of increasing the resistance in a circuit on the E.M.F	37 (92.5%)	3 (7.5%)	0 (0.0%)	1 (2.5%)	5 (12.5%)	34 (85.0%)
4. Effect of increasing the E.M.F in a circuit on the current	15 (37.5%)	24 (60.0%)	1 (2.5%)	0 (0.0%)	2 (5.0%)	38 (95.0%)

Note. IC = Incorrect, PC = Partial correct, C = Correct

Source: *Field Survey, 2022*

Table 11 clearly shows that, in the pretest, majority of the students 24(60.0%) defined Ohm's law incorrectly by stating that the current passing through the metallic conductor is directly proportional to the resistance or by not responding. Few students 14(35.0%) defined Ohm's law by indicating that the current passing through a metallic conductor is directly proportional to the potential difference but failed to add the condition 'at a constant temperature'. In contrast, majority of the students 36(90.0%) in the post-intervention test correctly defined Ohm's law by stating that for a metallic conductor, $V \propto I$ at a constant temperature.

On the effect of changing (increasing) the E.M.F. in a simple circuit and how the change affects the resistance of a metallic conductor, majority of the students 39(97.5%) responded incorrectly in the pre-intervention test by indicating that the E.M.F. affects the resistance of the metallic conductor or by leaving the response blank. However, in the post-intervention test, all the students 40(100.0%) mentioned that the resistance of a metallic conductor is only affected by the resistivity, length, cross-sectional area and the temperature but not the E.M.F.

When students were asked to explain the effect of changing the resistance in a circuit on the E.M.F, majority of them 37(92.5%) responded incorrectly in the pre-intervention test by indicating that the changing the resistance in a circuit will also change the E.M.F. or left the response blank. Few students 3(7.5%) mentioned that the E.M.F. remains the same but failed to explain why. However, in the post-intervention test, few students 5(12.5%) mentioned that the E.M.F. remains the same but failed to explain further. Majority of the students 34(85.0%) explained correctly that the E.M.F. remains the same because it is independent of the resistance.

Again, when students were asked about the effect of increasing the E.M.F. in a circuit on the current, a number of the students 15(37.5%) explained incorrectly in the pre-intervention test by indicating that increasing the E.M.F. does not affect the current in the circuit. Majority of the students 24(60.0%) mentioned that increasing the E.M.F. increases the current but failed to make reference to the formula $V=IR$. Only one student 1(2.5%) mentioned correctly that increasing the E.M.F. causes the current to also increase according to the formula $V=IR$, as V and I are directly proportional. However, in the post-intervention test, majority of the students 38(95.0%) mentioned correctly that increasing the E.M.F. causes the current to also increase according to the formula $V=IR$. Few students (25.0%) mentioned that increasing the E.M.F. increases the current but forgot to explain further by making reference to the formula $V=IR$.

Table 12 shows the performance of students in series connection of electrical components in the pre-interventional test and post-interventional test for 5.

Table 12: Performance in Series Connection of Electrical Components

Aspects	Pre-test			Post test		
	IC	PC	C	IC	PC	C
1. Calculating effective E.M.F of three cells in series with one in the reverse order.	26 (65.0%)	14 (35.0%)	0 (0.0%)	3 (7.5%)	5 (12.5%)	32 (80.0%)
2. Calculating the effective resistance in a series circuit	25 (62.5%)	12 (30.0%)	3 (7.5%)	0 (0.0%)	3 (7.5%)	37 (92.5%)
3. Find the current in a series circuit	28 (70.0%)	8 (20.0)	4 (10.0)	2 (5.0)	7 (17.5)	31 (77.5)
4. Description of the brightness of bulbs in a series circuit	35 (87.5%)	5 (12.5%)	0 (0.0%)	2 (5.0%)	5 (12.5%)	33 (82.5%)

Note. IC = Incorrect, PC = Partial correct, C = Correct

Source: *Field Survey, 2022*

When students were asked to explain the effect of connecting a bulb to a number of identical cells in series where one cell is connected in the reverse order on the bulb, Table 12 showed that majority of the students 26(65.0%) in the pre-intervention test mentioned that the bulb will not light. Some of the students 14(35.0%) also indicated that the bulb will light but failed to link the effect to the effective E.M.F. However, in the post-intervention test, majority of the students 32(80.0%) calculated the effective E.M.F by using the formula $E = E_1 + (-E_2) + E_3$ and concluded that the bulb will light up due the effective E.M.F.

In calculating the effective resistance in a series circuit, majority of the students 25(62.5%) had their response incorrect in the pre-intervention test as they failed to apply the formula $R = R_1 + R_2$. However, in the post-intervention test, majority of the students 37(92.5%) calculated the effective resistance in a series by using the formula $R = R_1 + R_2$.

Again, in the post-intervention test, majority of the students 31(77.5%) correctly found the current in a series circuit by using the idea that the current at all points in a series circuit is the same. In the pre-intervention test, majority of the students 28(70.0%) could not find the current in a series circuit as they failed to apply the concept that current all points in a series circuit is the same.

In the pre-intervention test 35(87.5%) of students gave an incorrect response by mentioning that more bulbs lead to more brightness. Again, 5(12.5%) of the students mentioned that the two identical bulbs connected to the 6V battery brightens more than the three identical bulbs connected to the same but failed to explain why. In the post-intervention test however, 33(82.5%) of the students gave a correct description of the

brightness of bulbs in a series circuit by indicating that the 2 bulbs in circuit 1 will shine brighter than the 3 bulbs in circuit 2 even though the bulbs in the different circuits are all powered by a 6V power source respectively due to the fact that more current flows in circuit 1 than in circuit 2.

Table 13 shows the performance of students in the parallel connection of electrical components in the pre-interventional test and post-interventional test for lesson

Table 13: Performance in Parallel Connection of Electrical Components

Aspects	Pre-test			Posttest		
	IC	PC	C	IC	PC	C
1. Finding the potential difference across electrical components in a parallel circuit	26 (65.0%)	10 (25.0%)	4 (10.0%)	0 (0.0%)	5 (12.5%)	35 (87.5%)
2. Calculating the effective resistance in a parallel circuit	27 (67.5%)	11 (27.5%)	2 (5.0%)	1 (2.5%)	6 (15.0%)	33 (82.5%)
3. Finding the current of all branches of a parallel circuit	37 (92.5%)	2 (5.0%)	1 (2.5%)	0 (0.0%)	3 (7.5%)	37 (92.5%)
4. Explanation to why similar bulbs produce similar brightness but dissimilar bulbs produce varying brightness in a parallel circuit	29 (72.5%)	10 (25.0%)	1 (2.5%)	2 (5.0%)	4 (10.0%)	34 (85.0%)

Note. IC = Incorrect, PC = Partial correct, C = Correct

Source: *Field Survey, 2022*

From Table 13, it was revealed that majority of the students 26(65.0%) could not find the P.d across a component in a parallel circuit in the pre-intervention test by using the formula $V = V_1 = V_2$. A few students 10(25.0%) mentioned the correct value but failed to support the response with a reason. However, in the post-intervention test, majority of the students 35 (87.5%) found the P.d. by applying the fact that the P.d. across each

components in a parallel circuit is the same ($V = V_1 = V_2$). A few students 5(12.5%) gave the correct response but failed to support the response with a reason.

In calculating the effective resistance in a parallel circuit, few students 2(5.0%) were able to use the formula $\frac{1}{R} = \frac{1}{R_1} + \frac{1}{R_2}$. to appropriately determine the effective resistance in parallel circuit in the pre-intervention test. Similarly, majority of the students 27(67.5%) had their responses incorrect in the pre-intervention test as they failed to quote and apply the formula $\frac{1}{R} = \frac{1}{R_1} + \frac{1}{R_2}$. Again, 11(27.5%) of the students gave the correct response but failed to support their responses with the appropriate reason. However, in the post-intervention test, majority of the students 33(82.5%) calculated the effective resistance in a parallel by using the formula $\frac{1}{R} = \frac{1}{R_1} + \frac{1}{R_2}$. Whereas 6(15.0%) had the correct value of effective resistance without supporting the response with a reason, 1(2.5%) of the students could not quote and apply the formula $\frac{1}{R} = \frac{1}{R_1} + \frac{1}{R_2}$. Therefore, the responses were incorrect in the post-intervention test.

In finding the current of all branches of a parallel circuit, a few students 1(2.5%) were able to use the formula $I = I_1 + I_2$ to appropriately determine the currents in the branches of a parallel circuit and went further to rank them in the pre-intervention test. On the other hand, majority of the students 37(92.5%) had their response incorrect in the pre-intervention test as they failed to quote and apply the formula $I = I_1 + I_2$. Again, 2(5.0%) of the students gave the correct response but failed to rank the currents from the highest to the lowest. However, in the post-intervention test, majority of the students 33(82.5%) calculated the currents in all the branches of a parallel circuit by using the formula $I = I_1 + I_2$. and then ranked them accordingly from the highest to the lowest. Similarly in the post-intervention test, 6(15.0%) of the students had the correct value of currents but

failed to rank them. Again, 1(2.5%) of the students could not use the formula $I = I_1 + I_2$ to find the currents in the branches in the parallel circuit

In explanation to why similar bulbs produce similar brightness but dissimilar bulbs produce varying brightness in a parallel circuit, 29(72.5%) incorrectly indicated in the pre-intervention test that the differences in the brightness was that in one case the bulbs were the same on while in the other the bulbs were different. In the post-intervention test, 34(85.0%) of the students gave a correct description of the brightness of bulbs in a parallel circuit by indicating that the current passing through the similar bulbs is the same ($I_1 = I_2$. or $I = 2I_1$) whereas the current passing through the dissimilar bulbs were different ($I = I_1 + I_2$).

4.1.2.2 Presentation of semi-structured interview data

When students were asked how their performance had been since they were introduced to the teaching strategy (TMHC), the following are some of their responses:

G1S4: *It is better than the start. I can now solve more questions correctly than before with confidence.*

G2S2: *I can connect the voltmeter to a circuit to measure the pd across a particular component now.*

G3S5: *I can now connect the electrical components to build a circuit by looking at the circuit diagram*

G4S7: *I have had a bigger score and have become better at plotting graphs in physics.*

From the responses, it is evident that students believed that the teaching intervention with TMHCC had improved their problem-solving competencies, and improved their skills (connection of electrical components and graph plotting skills).

Discussion of Results for Research Question 2

Research question two sought to find out the performance of students in the selected topics taught through the conceptual change approach. The analysis of pre-intervention and post-intervention test results revealed a notable trend wherein majority of students exhibited higher scores on the post-intervention test compared to the pre-intervention test (Table 8, Table 9, Table 10, Table 11, Table 12, and Table 13). This observation was further substantiated by instances where students corrected previously erroneous responses, indicating a deeper understanding of the subject matter following the intervention with TMHCC. That is, students were more proficient in defining, stating reasons, drawing, describing, explaining, and performing calculations in the post-intervention test than in the pre-intervention test. The findings of this study resonate with existing literature, particularly the works of Achor and Abuh (2020) as well as Davis (2001), which underscore the positive impact of conceptual change pedagogy on students' performance in physics. By engaging students' metacognition, fostering cognitive conflict, and leveraging motivational constructs such as collaborative group work and feedback mechanisms, conceptual change approaches have been shown to facilitate significant improvements in student learning outcomes (Chi, 2008; Jonassen, Strobel, & Lee, 2006). The observed enhancements in students' performance can be attributed to several factors inherent in the TMHCC. The integration of metacognitive strategies encourages students to monitor and regulate their learning processes, leading to deeper levels of understanding (Flavell, 1979). Cognitive conflict, inherent in the TMHCC, prompts students to confront and resolve inconsistencies between their existing conceptions and scientific principles, thereby fostering conceptual restructuring (Posner et al., 1982). Additionally, motivational factors such as group work and feedback mechanisms serve to sustain student engagement and intrinsic

motivation, contributing to improved learning outcomes (Pintrich, Marx, & Boyle, 1993). Insights gleaned from focused group interviews provided qualitative evidence that corroborated the quantitative findings of the pre-intervention and post-intervention tests. Students' reported improvements in problem-solving competencies, understanding of electrical components, and graph plotting skills underscored the holistic impact of the TMHCC intervention on various facets of learning. This triangulation of data sources lends robust support to the assertion that TMHCC effectively enhances student learning outcomes in physics education.

4.1.3 Analysis with Respect to Research Question Three

RQ3: What conceptual changes occurred during the use of the Teaching Model for Hot Conceptual change to teach the selected topics in physics?

4.1.3.1 Presentation of test data

Students' incorrect responses as well as partially correct responses were further analysed to identify misconceptions. A frequency analysis of students' misconceptions in both pre-intervention and post-intervention tests was performed and a bar graph was plotted. Figure 5 shows the rate of occurrence of students' misconceptions before and after the intervention with TMHCC.

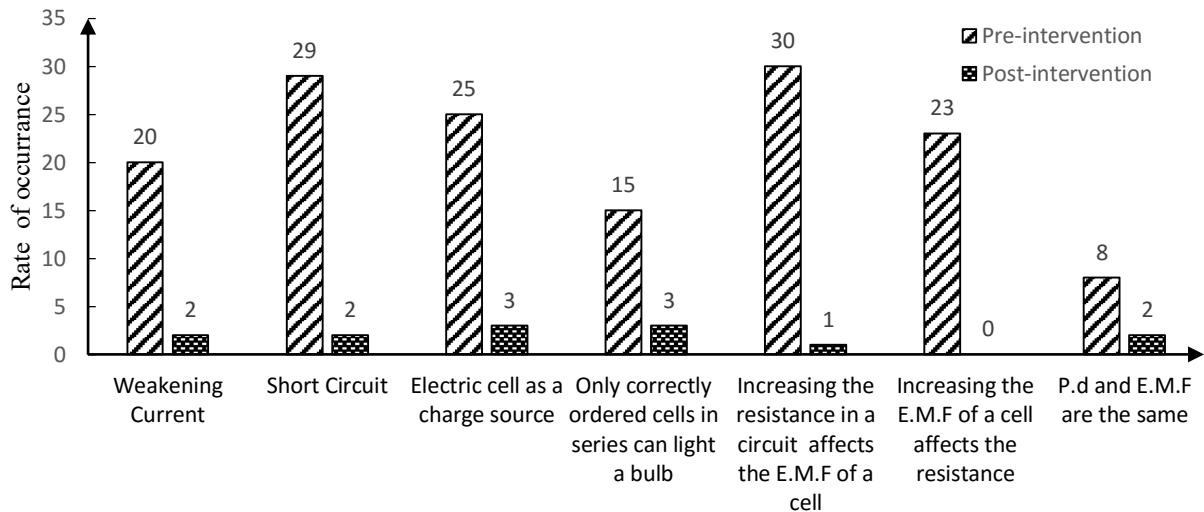

Figure 5: Rate of occurrence of students' misconceptions before and after the intervention with the TMHCC

From Figure 5, it is clear that majority of the students in the pre-intervention test adopted the increasing resistance affects the E.M.F misconception. However, there was a sharp decline in the number in the post-intervention test. Similarly, the number of students that adopted the weakening current, electric cell as a charge source, only correctly ordered cells in series can light up a bulb, P.d and E.M.F. are same, and the short circuit misconceptions respectively dropped after instruction. Instruction was effective at reducing the number of students that adopted the increasing the E.M.F. of a cell affects the resistance misconception to zero in the posttest.

4.1.3.2 Presentation of semi-structured interview data

From the focused group interview, the following are some of the responses students gave when asked if there was a point in their understanding where they had an idea (or ideas) about a particular topic that was scientifically incorrect, what those ideas or conceptions were, and whether the idea(s) had changed as a result of the teaching

strategy:

G1S3: *Yes Sir! At first, I thought E.M.F and P.d. were the same. I later realised that they are different even though they have the same unit.*

G2S1: *Yes, there was a point like that. When I heard of the term short circuit, all that came to mind was a circuit that is short. But I now know that short circuit is when an electric current flows down the wrong or unintended path with little to no electrical resistance*

G3S7: *Yes. My torchlight in the home uses two tiger head batteries. When I turn one in the wrong direction, the bulb does not light. So I didn't believe three batteries with some in the wrong direction could also light a bulb. After the lessons, I now know better.*

G4S10: *Yes! From JHS, I got to know the formula $V=IR$. Like maths, if $Z = xy$, then if I change x or y , z will change. So I thought changing R should affect V . But after the lesson, I got to know that if V is the emf, then changing R does not affect V .*

It was explicit from the above statements that most of the students had a misconception at some point in their understanding. However, the intervention helped change those misconceptions to acceptable scientific knowledge. The misconceptions revealed through the analysis are the short circuit misconceptions, the increasing resistance affects the E.M.F, only correctly ordered cells in series can light up a bulb and lastly P.d and E.M.F. are the same.

4.1.3.3 Presentation of fieldnotes data

During the elicitation of preconception stage in the teaching intervention, the following misconceptions were noted in students' responses:

1. The bulbs consume the charges. That is why the battery runs down and is recharged or replaced.
2. Short circuit refers to a circuit which is built using short wires such that the whole circuit end up being short.
3. Potential difference (P.d.) and electromotive force (E.M.F) are the same because they have the same unit.
4. The charges that move in the circuit originate from the cell. That is why we recharge a cell or replace it when there are no charges left in it.
5. Increasing resistance affects the E.M. F
6. Increasing the E.M.F. of a cell affects the resistance
7. Only correctly ordered cells in series can light up a bulb

Discussion of Results for Research Question 3

Research question three sought to find out the conceptual changes that occurred during the use of the TMHCC to teach selected topics in current electricity. Students' incorrect responses as well as partially correct responses were further analysed to identify misconceptions. The findings from the frequency analysis of students' preconceptions in both pre-intervention and post-intervention tests revealed that students have preconceptions before being introduced to a new concept and of which some of the preconceptions happen to be misconceptions (Figure 5). The findings confirm the work of Baser (2006) who stated that students come to class with misconceptions and these turn to affect students' conceptual understanding. Similarly, the findings from this

study indicated that students have some misconceptions about electricity. The result aligns with the works of several researchers who mentioned that students have several misconceptions about electricity which comes about partly due to the complex nature of the electricity concept (Aligo et al., 2021; Mboniyirivuze et al., 2022; Sencar & Eryilmaz, 2004). These misconceptions come about as a result of everyday language, culture and religion, textbooks, teachers and interaction with the environment. The misconceptions revealed through the analysis are the short circuits, weakening current, increasing resistance affects the E.M.F, increasing the E.M.F affects the resistance, the electric cell as a charge source, only correctly ordered cells in series can light up a bulb and lastly P.d and E.M.F. are the same. While the short circuit, weakening current, increasing resistance affects the E.M.F, increasing the E.M.F affects the resistance, the electric cell as a charge source are profound in literature (Aligo et al., 2021; Mboniyirivuze et al., 2022; Sencar & Eryilmaz, 2004), the same cannot be said about only correctly ordered cells in series can light up a bulb and P.d and E.M.F. are the same misconception. This finding builds on the existing literature on students' misconceptions of current electricity.

From the findings, it became evident that students' misconceptions reduced after the intervention. This was consistent with the work of Kural and Kocakulah (2016) who explained that TMHCC helps students to change their prior knowledge towards acceptable scientific conceptions. Although students' misconceptions were reduced, some still remained. This was in line with the findings of Phanphech, Tanitteerapan, and Murphy (2019) who discovered that misconceptions among vocational students decreased after the intervention but were not completely eliminated due to the fact that misconceptions are persistent to change. The findings from the focused group interview validated the findings from the quantitative analysis. The results from the

interview revealed that most of the students had misconceptions at some point in their understanding. However, the intervention helped change those misconceptions to acceptable scientific knowledge. The misconceptions revealed through the analysis are the short circuit misconceptions, the increasing resistance affects the E.M.F, only correctly ordered cells in series can light up a bulb and lastly P.d and E.M.F. are the same.

From the discussions so far, there seems to be growing evidence that the implementation of the Teaching Model for Hot Conceptual Change approach to teaching some selected topics in the current electricity had a significant impact on students' academic performance.

4.2 Summary

A detailed examination of the data from the research instruments utilised for the study was performed to look for any indications of changes in student performance in current electricity. The analysis of findings showed that after students were exposed to TMHCC, their academic performance had significantly improved. This study lends credence to a number of conclusions made by scholars including Kural and Kocakülah (2016) and Phromsena et al. (2019) who found and reported that using TMHCC improves students' performance.

CHAPTER FIVE

SUMMARY, CONCLUSION AND RECOMMENDATIONS

5.0 Overview

This chapter gives a summary of the findings and salient issues that emerged from the study. The chapter also draws a conclusion on the outcome of the study. Based on the study's findings, recommendations and implications have also been presented.

5.1 Summary of Findings

This study sought to determine the effect of implementing the Teaching Model for Hot Conceptual change (TMHCC) on SHS Two (2) Agric1 students' academic performance Winneba Secondary School. The Action research method was used for the study. The researcher implemented the TMHCC over the six lessons. The following were the major findings that emerged from the study:

1. Students have preconceptions before being introduced to a new concept and among the pool of preconceptions students brought to class were misconceptions. Some misconceptions identified and reduced through the teaching intervention are:
 - the short circuit misconceptions
 - the weakening current (decrease in current along the circuit due decreasing charges)
 - the increasing resistance affects the E.M.F
 - the increasing the E.M.F. of a cell affects the resistance
 - electric cell as a charge source
 - only correctly ordered cells in series can light up a bulb
 - P.d and E.M.F. are the same

2. Majority of the students answered the pre-intervention test incorrectly but correctly in the post-intervention test. Students were more confident and proficient in defining, stating reasons, drawing, describing, explaining, and performing calculations in the post-intervention test than in the pre-intervention test.
3. Majority of students signified that TMHCC has improved their problem-solving competencies, graph plotting skills manipulation and connection of electrical circuit skills, critiquing and communication skills and finally changed their attitudes towards physics.

5.2 Conclusion

The Teaching Model for Hot Conceptual Change (TMHCC) lends itself to the identification and remedying of students' misconceptions through the active engagement of students' metacognition, creation of cognitive conflict, and utilisation of motivational constructs. The TMHCC improved students conceptual understanding of current electricity as students were able to transfer learned concepts to different situations. Improvement noted in students' critical thinking, critique, collaboration, communication, circuit connection, measurement skills, and attitudes towards learning physics as evidenced by punctuality, attentiveness, and enthusiasm. Drawing from the findings of this study and the works by Kural and Kocakulah (2016), along with those of Phromsena et al. (2019), which demonstrate the effectiveness of TMHCC in enhancing students' performance, it is evident that implementing TMHCC significantly impacts students' academic performance.

5.3 Recommendations

The following recommendations are made based on the findings of the research for policy and practice.

1. The preconceptions identified in this study revealed that students have issues with electric current, P.d and E.MF, Electrical resistance, Ohm's law, series and parallel connection of electrical components respectively. Consequently, teachers should place more importance on teaching effectively such concepts so that students are able to grasp and overcome their inability to understand them. Students must be provided with some more opportunities for making them understand it.
2. An effective conceptual change approach to teaching such as the TMHCC, requires a great amount of effort from the teachers. The success of its implementation requires that teachers have to be aware of students' preconceptions and their possible misconceptions and direct the classroom activities accordingly. It is recommended that in-service training should be organised for physics teachers by Head of Physics department in collaboration with well experienced physics well abreast with conceptual change and students misconceptions in current electricity train them on how to use the Teaching Model for Hot Conceptual change effectively.
3. Conceptual change is a complex process and requires the proper environment and educational materials and equipment. Therefore, the school and management should help to equip the classrooms and/or laboratories with the necessary materials and computer equipment which will go a long way to facilitate the conceptual change process.

4. The misconceptions detected by this study can be a useful resource for teachers to help them design an effective lesson to address students' misconceptions in current electricity.

5.4 Suggestions for Further Research

1. The study was limited to only one major topic which was current electricity. It is suggested that the study be replicated using the Teaching Model for Hot Conceptual Change in other areas of physics such as Optics, Sound waves, Magnetism, Heat, Mechanics, Nuclear physics, and Electronics. Based on these there could be a greater generalisation of the conclusions drawn from the findings of the study.
2. It is suggested that similar studies should be carried out on the use of the Teaching Model for Hot Conceptual Change in other science subject areas and at different levels of Science Education to provide a sound basis for the integration of the Teaching Model for Hot Conceptual Change in Science Education in Ghanaian schools.
3. The study should be replicated using the Teaching Model for Hot Conceptual Change in other regions and districts in Ghana.

REFERENCES

- Aboagye, G.K. (2009). *Effectiveness of Learning Cycle in Exploring Students' Preconceptions on Selected Concepts in Direct Current Electricity*. Unpublished Master's Thesis, University of Cape Coast. Retrieved on April 6, 2022 from <http://hdl.handle.net/123456789/1172>
- Achor, E. E., & Abuh, P. Y. (2020). Fostering students' academic performance in physics using cognitive conflict instructional strategy and conceptual change pedagogy. *International Journal of Education and Learning*, 2(1), 42-57.
- Adams, W. K., & Wieman, C. E. (2011). Development and validation of instruments to measure learning of expert- like thinking. *International journal of science education*, 33(9), 1289-1312.
- Aina, J. K. (2017). Developing a constructivist model for effective physics learning. *International Journal of Trend in Scientific Research and Development*, 1(4), 59-67.
- Ainley, M., & Ainley, J. (2011). Student engagement with science in early adolescence: The contribution of enjoyment to students' continuing interest in learning about science. *Contemporary educational psychology*, 36(1), 4-12.
- Aligo, B. L., Branzuela, R. L., Faraon, C. A. G., Gardon, J. D., & Orleans, A. V. (2021). Teaching and Learning Electricity—A Study on Students' and Science Teachers' Common Misconceptions. *Manila Journal of Science*, 14, 22-34.
- Alsop, S., & Watts, M. (1997). Sources from a Somerset village: A model for informal learning about radiation and radioactivity. *Science Education*, 81(6), 633-650.
- Alsop, S., & Watts, M. (2000). Interviews-about-Scenarios: Exploring the Affective Dimensions of Physics Education. *Research in Education*, 63(1), 21–32. <https://doi.org/10.7227/RIE.63.3>
- Alzahrani, I., & Woollard, J. (2016). The Role of the Constructivist Learning Theory and Collaborative Learning Environment on Wiki Classroom, and the Relationship between Them. *International Journal of Educational and Pedagogical Sciences*, 10(3), 891-894.
- Amineh, R. J., & Asl, H. D. (2015). Review of Constructivism and Social Constructivism. *Journal of Social Sciences, Literature, and Languages*, 1(1), 9-16.
- Anamuah-Mensah, J. (2007). The Educational Reform and Science and Mathematics Education. In *A Keynote Address at the Stakeholders of Nuffic Practical Project Meeting*.
- Asgari, M., Ahmadi, F., & Ahmadi, R. (2018). Application of conceptual change model in teaching basic concepts of physics and correcting misconceptions. *Iranian Journal of Learning and Memory*, 1(1), 69-83.

- Ates, S. (2005). The effectiveness of the learning- cycle method on teaching DC circuits to prospective female and male science teachers. *Research in Science & Technological Education*, 23(2), 213-227.
- Au, K.H. (2005). Social constructivism and the school literacy learning of students diverse backgrounds. *Journal of Literacy Research*,7(30), 29-79.
- Baser, M. (2006). Effect of Conceptual Change Oriented Instruction on Students' Understanding of Heat and Temperature Concepts. *Journal of Maltese Education Research*,4(1), 64-79.
- Baser, M., & Geban, Ö. (2007). Effectiveness of conceptual change instruction on understanding of heat and temperature concepts. *Research in science & technological education*,25(1), 115-133.
- Brookhart, S. M., & Nitko, A. J. (2019). *Educational assessment of students*. Upper Saddle River, NJ: Pearson.
- Brownstein, B. (2001). Collaboration: The foundation of learning in the future. *Education*, 122(2), 240
- Buchwald, E. J. (2017). Equity and diversity in physics education. In S. E. Kanim (Ed.), *Equity and Access in Physics Education* (pp. 3-28). Springer.
- Casteel, A., & Bridier, N. L. (2021). Describing populations and samples in doctoral student research. *International Journal of Doctoral Studies*, 16, 339-362. <https://doi.org/10.28945/4766>
- Chi, M. T., Slotta, J. D., & De Leeuw, N. (1994). From things to processes: A theory of conceptual change for learning science concepts. *Learning and instruction*, 4(1), 27-43.
- Chi, M. T. (2005). Commonsense conceptions of emergent processes: Why some misconceptions are robust. *The journal of the learning sciences*, 14(2), 161-199.
- Chi, M. T. H. (2008). Three types of conceptual change: Belief revision, mental model transformation, and categorical shift. In S. Vosniadou (Ed.), *International Handbook of Research on Conceptual Change* (pp. 61-82). Routledge.
- Chi, M. T. (2009). Three types of conceptual change: Belief revision, mental model transformation, and categorical shift. In *International handbook of research on conceptual change* (pp. 89-110). Routledge.
- Closset, J. L. (1983, June). Sequential reasoning in electricity. In *Research on Physics Education. Proceedings of the First International Workshop* (pp. 313-319). Paris: Editions du Centre National de Recherche Scientifique.

- Cohen, L., Manion, L., & Morrison, K. (2018). *Research Methods in Education* (8th ed.). London: Routledge. <https://doi.org/10.4324/9781315456539>
- Creswell, J. W., & Plano Clark, V. L. (2011). *Designing and conducting mixed methods research* (2nd ed.). Thousand Oaks, CA: Sage Publications
- Davis, J. (2001). Conceptual Change. In M. Orey (Ed.), *Emerging perspectives on learning, teaching, and technology*. Retrieved January 10, 2022, from <http://epltt.coe.uga.edu/>
- Denis, U., Williams, J. J., Dunnamah, A. Y., & Tumba, D. P. (2015). Conceptual change theory as a teaching strategy in environmental education. *European Scientific Journal*, 11(35), 395-408.
- Dole, J. A., & Sinatra, G. M. (1998). Reconceptualizing change in the cognitive construction of knowledge. *Educational psychologist*, 33(2-3), 109-128.
- Duncan, R. G., Breslow, L., & Elby, A. (2018). A framework for understanding physics students' cognitive processing during active learning instructional activities. *Physical Review Physics Education Research*, 14(1), 010113.
- Duit, R., & Treagust, D. F. (2003). Conceptual change: A powerful framework for improving science teaching and learning. *International journal of science education*, 25(6), 671-688.
- Duit, R., Treagust, D. F., & Widodo, A. (2013). Teaching science for conceptual change: Theory and practice. In *International handbook of research on conceptual change* (pp. 499-515). Routledge.
- Engelhardt, P. V., & Beichner, R. J. (2004). Students' understanding of direct current resistive electrical circuits. *American journal of physics*, 72(1), 98-115.
- Field A. (2018). *Discovering statistics using IBM SPSS statistics* 5th ed. SAGE Publications.
- Flavell, J. H. (1979). Metacognition and cognitive monitoring: A new area of cognitive–developmental inquiry. *American psychologist*, 34(10), 906.
- Freeman, S., Eddy, S. L., McDonough, M., Smith, M. K., Okoroafor, N., Jordt, H., & Wenderoth, M. P. (2014). Active learning increases student performance in science, engineering, and mathematics. *Proceedings of the national academy of sciences*, 111(23), 8410-8415.
- Gafoor, K. A., & Akhilesh, P. T. (2010). Strategies for Facilitating Conceptual Change in School Physics. *Innovations and Researches in Education*, 3(1), 34 - 42.
- Glynn, S. M., Taasobshirazi, G., & Brickman, P. (2007). Nonscience majors learning science: A theoretical model of motivation. *Journal of Research in Science Teaching: The Official Journal of the National Association for Research in Science Teaching*, 44(8), 1088-1107.

- Gregoire, M. (2003). Is it a challenge or a threat? A dual-process model of teachers' cognition and appraisal process during conceptual change. *Educational Psychology Review*, 15, 117–155.
- Gunstone, R., Mulhall, P., & McKittrick, B. (2009). Physics teachers' perceptions of the difficulty of teaching electricity. *Research in Science education*, 39(4), 515-538.
- Guskey, T. R. (2010). Lessons of mastery learning. *Educational leadership*, 68(2), 52-57.
- Hake, R. R. (1998). Interactive-engagement versus traditional methods: A six-thousand-student survey of mechanics test data for introductory physics courses. *American journal of Physics*, 66(1), 64-74.
- Hein, G. E. (2007). *Constructivist Learning Theory*. Massachusetts. Lesley College Press
- Hestenes, D. (2006). Notes for a modeling theory of science, cognition and instruction. In E. van Zee & J. Minstrell (Eds.), *Inquiring into Inquiry Learning and Teaching in Science* (pp. 371-388). American Association for the Advancement of Science.
- Hulleman, C. S., Durik, A. M., Schweigert, S. A., & Harackiewicz, J. M. (2008). Task values, achievement goals, and interest: an integrative analysis. *Journal of educational psychology*, 100(2), 398.-416
- Jaleel, S. (2016). A Study on the Metacognitive Awareness of Secondary School Students. *Universal Journal of Educational Research*, 4(1), 165-172.
- Johnson, R. B., & Onwuegbuzie, A. J. (2004). Mixed methods research: A research paradigm whose time has come. *Educational researcher*, 33(7), 14-26.
- Jonassen, D., Strobel, J., & Lee, C. B. (2006). Everyday problem solving in engineering: Lessons for engineering educators. *Journal of engineering education*, 95(2), 139-151.
- Kanselaar, G. (2002). *Constructivism and socio-constructivism*. Retrieved January 11, 2022, from <https://kanselaar.net/wetenschap/files/Constructivism-gk.pdf>
- Kim, B. (2001). Social constructivism. *Emerging perspectives on learning, teaching, and technology*, 1(1), 16.
- Küçüközer, H. & Kocakulah, S. (2007). Secondary school students' misconceptions about simple electric circuits. *Journal of Turkish Science Education*, 4(1), 101-115.
- Kural, M., and Kocakulah, S. M. (2016). Teaching for hot conceptual change: towards a new model, beyond the cold and warm ones. *European Journal of Education Studies*, 8(2), 1-40.

- Limón, M. (2001). On the cognitive conflict as an instructional strategy for conceptual change: A critical appraisal. *Learning and Instruction*, 11(4–5), 357–380.
- Lombardi, D., & Sinatra, G. M. (2012). College students' perceptions about the plausibility of human-induced climate change. *Research in Science Education*, 42, 201-217.
- Mascolo, M. F., & Fischer, K. W. (2005). *Constructivist theories*. Cambridge Encyclopedia of Child Development (pp. 49-63). Cambridge, England: Cambridge University Press.
- Mbonyiryivuze, A., Yadav, L. L., & Amadalo, M. M. (2022). Physics students' conceptual understanding of electricity and magnetism in nine years basic education in Rwanda. *European Journal of Educational Research*, 11(1), 83-101. <https://doi.org/10.12973/eu-jer.11.1.83>
- Miles, M. B., Huberman, A. M., & Saldaña, J (2014). *Qualitative data analysis: A methods sourcebook*. Sage publications.
- McDermott, L. C., & Shaffer, P. S. (1992). Research as a guide for curriculum development: An example from introductory electricity. Part I: Investigation of student understanding. *American journal of physics*, 60, 994-994.
- Meltzer, D. E., & Manivannan, K. (2002). Transforming the lecture-hall environment: The fully interactive physics lecture. *American Journal of Physics*, 70(6), 639-653.
- Meltzer, D. E., & Thornton, R. K. (2012). Resource letter ALIP–1: active-learning instruction in physics. *American journal of physics*, 80(6), 478-496.
- Mogashoa, T. (2014). Applicability of constructivist theory in qualitative educational research. *American International Journal of Contemporary Research*, 4(7), 51-59.
- Muhammad, A. S., Bakar, N. A., Mijinyawa, S. I., & Halabi, K. A. (2015). Impact of motivation on students' academic performance: A case study of University Sultan Zainal Abidin students. *The American Journal of Innovative Research and Applied Sciences*, 1(6), 221-226.
- Ozkan, G., & Selçuk, G. S. (2012). How effective is “conceptual change approach” in teaching physics. *Journal of educational and Instructional Studies in the World*, 2(2), 182-190.
- Palmer, D. (2005). A motivational view of constructivist-informed teaching. *International Journal of Science Education*, 27(15), 1853–1881.
- Pellegrino, J. W., Chudowsky, N., & Glaser, R. (Eds.). (2001). *Knowing what students know: The science and design of educational assessment*. National Academies Press.

- Phanphech, P., Tanitteerapan, T., & Murphy, E. (2019). Explaining and enacting for conceptual understanding in secondary school physics. *Issues in Educational Research*, 29(1), 180-204.
- Phromsena, P., Promratana, P. L., & Panchompoo, J. (2019). Effects of Teaching Model for Hot Conceptual Change on Students' Chemistry Conceptions. *Scholar: Human Sciences*, 11(1), 162-169
- Piaget, J. (2001). *The psychology of intelligence*. Oxford, UK: Routledge.
- Pintrich, P. R., Marx, R. W., & Boyle, R. A. (1993). Beyond cold conceptual change: The role of motivational beliefs and classroom contextual factors in the process of conceptual change. *Review of Educational research*, 63(2), 167-199.
- Pintrich, P. R. (2003). A motivational science perspective on the role of student motivation in learning and teaching contexts. *Journal of Educational Psychology*, 95(4), 667-686.
- Popham, W. J. (2011). Assessment literacy overlooked: A teacher educator's confession. *The Teacher Educator*, 46(4), 265-273.
- Prince, M. (2004). Does active learning work? A review of the research. *Journal of engineering education*, 93(3), 223-231.
- Rhöneck, C. von, & Grob, K. (1987). Representation and problem-solving in basic electricity, predictors for successful learning. In J. D. Novak (Ed.), *Proceedings of the Second International Seminar on Misconceptions and Educational Strategies in Science and Mathematics*, Ithaca, NY: Misconceptions Trust.
- Robottom, I. (2004). Constructivism in environmental education: Beyond conceptual change theory. *Australian Journal of Environmental Education*, 20(2), 93-101.
- Sadler, D. R. (2005). Interpretations of criteria- based assessment and grading in higher education. *Assessment & evaluation in higher education*, 30(2), 175-194.
- Sebastia, J.M. (1993). Cognitive mediators and interpretations of electric circuits. In *The proceedings of the third international seminar on misconceptions and educational strategies in science and mathematics*. Ithaca, NY: Cornell University.
- Sencar, S., Eryilmaz, A. (2004). Factors mediating the effect of gender on ninth-grade Turkish students' misconceptions concerning electric circuits. *Journal of Research in Science Teaching*, 41(6), 603-616.
- Seymour, E., & Hewitt, N. M. (1997). *Talking about leaving: Why undergraduates leave the sciences*. Westview Press.
- She, H. C. (2002). Concepts of a higher hierarchical level require more dual situated learning events for conceptual change: A study of air pressure and buoyancy. *International Journal of Science Education*, 24(9), 981-996.

- Sinatra, G. M. & Pintrich, P. R. (2003). *Intentional conceptual change*. Mahwah, NJ: Lawrence Erlbaum Associates.
- Sinatra, G. M. (2005). The warming trend in conceptual change research: The legacy of Paul R. Pintrich. *Educational Psychologist*, 40, 107–115.
- Taasoobshirazi, G., & Sinatra, G. M. (2011). A structural equation model of conceptual change in physics. *Journal of Research in Science Teaching*, 48(8), 901-918.
- Tam, M. (2000). Constructivism, Instructional Design, and Technology: Implications for Transforming Distance Learning. *Educational Technology and Society*, 3(2), 50-60
- Thagard, P. (2014). Explanatory identities and conceptual change. *Science Education*, 23, 1531–1548.
- Treagust, D. F., & Duit, R. (2008). Conceptual change: a discussion of theoretical, methodological, and practical challenges for science education. *Cultural Studies of Science Education*, 3(2), 297-328.
- Vosniadou, S (2004). Extending the conceptual change approach to mathematics learning, *Teaching and Instruction*, 14, 445-451.
- Vosniadou, S. (2007). The cognitive-situative divide and the problem of conceptual change. *Educational Psychologist*, 42(1), 55-66.
- Wang, H. S., Chen, S., & Yen, M. H. (2021). Effects of metacognitive scaffolding on students' performance and confidence judgments in simulation-based inquiry. *Physical Review Physics Education Research*, 17(2), 020108.
- Wiggins, G. (1998). *Educative Assessment. Designing Assessments To Inform and Improve Student Performance*. Jossey-Bass Publishers, 350 Sansome Street, San Francisco, CA 94104.
- Yildiz, E. (2008). *The effects of metacognition during the instruction based on conceptual change used with 5E model: An application regarding the force and motion subject in the 7th grade*. Unpublished Doctoral Dissertation, Dokuz Eylul University, Izmir.
- Zhou, G. (2010). Conceptual change in science: A process of argumentation. *Eurasia Journal of Mathematics, Science & Technology Education*, 6(2), 101-110.

APPENDIX A

ELECTRICITY CONCEPTS TEST (ECT) FOR LESSON 1

PART 1 -- PRETEST

Please answer all questions in the test

TIME - 15MINS

1. Define the term electric current
2. What is meant by the term short circuit?
3. What is the difference between conventional current and electron flow
4. If the charges passing through a particular point in a circuit in time t are tripled, what happens to the current?
5. A student stated that “an electric bulb consumes the charges that enter it to brighten up therefore the current flowing back to the cell reduces”. What can you say about the statement made by the students?
6. With the aid of a diagram, describe how you would connect an ammeter in a circuit to measure the current.

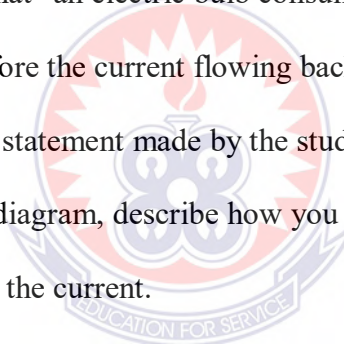

PART 2 -- POSTTEST

Please answer all questions in the test

TIME - 20MINS

1. Define the term electric current
2. Consider the circuit below. If a wire is connected between points X and Y, explain what will happen to bulb B_1 ?
3. What is the difference between conventional current and electron flow.
4. A charge Q passes a particular point in a circuit in time t .

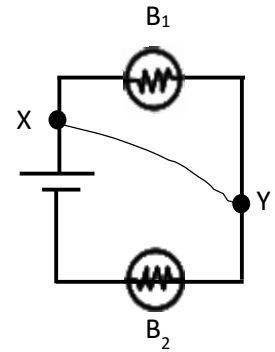

- If the time the charge passes the point is halved, what happens to the current?
5. A student stated that, “the charges that enters an electric bulb is more than the number that leaves the bulb”. What can you say about the statement made by the students?
 6. With the aid of a diagram, describe how you would connect an ammeter in a circuit to measure the current.

APPENDIX B

ELECTRICITY CONCEPTS TEST (ECT) FOR LESSON 2

PART 1 -- PRETEST

Please answer all questions in the test

TIME - 20MINS

1. The potential difference and E.M.F. are the same. What is your take on this statement?
2. The charge that flows in the circuit originates from the electric cells. What is your take on this statement?
3. Calculate the voltage of a battery if it supplies 4Joules of energy to 3C of charge.
4. With the aid of a diagram, describe how you would connect a voltmeter in a circuit to measure the voltage

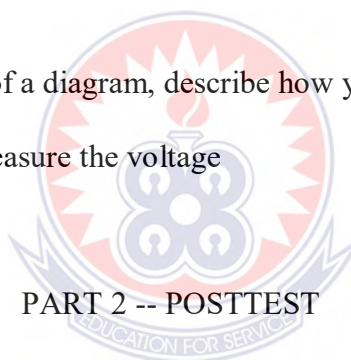

PART 2 -- POSTTEST

Please answer all questions in the test

TIME - 20MINS

1. State the difference between the potential difference and E.M.F.
2. The charge that flows in the circuit originates from the electric cells
What is your take on this statement?
3. Calculate the voltage of a battery if it supplies 6J of energy to 500mC of charge.
4. With the aid of a diagram, describe how you would connect a voltmeter in a circuit to measure the voltage

APPENDIX C

ELECTRICITY CONCEPTS TEST (ECT) FOR LESSON 3

PART 1 -- PRETEST

Please answer all questions in the test

TIME - 20MINS

1. Define the term electrical resistance.
2. A metallic conductor has resistance R . If the conductor is stretched to a new length greater than the original, what will be the effect on the resistance of the conductor?
3. A metallic conductor has resistance R . If the cross-sectional area A of the conductor is increased without increasing the original length, what will be the effect on the resistance of the conductor?
4. How does increase in temperature affect the resistance of a metallic conductor?



PART 2 -- POSTTEST

Please answer all questions in the test

TIME - 20MINS

1. Define the term electrical resistance.
2. A metallic conductor has resistance R . If the conductor is stretched to a new length 3 times the initial length, find the resistance of the conductor?
3. A metallic conductor with a cross sectional area A has resistance R . If the cross sectional area of the conductor is halved without increasing the original length, find the resistance of the conductor?
4. How does temperature affect the resistance of a metallic conductor?

APPENDIX D

ELECTRICITY CONCEPTS TEST (ECT) FOR LESSON 4

PART 1 -- PRETEST

Please answer all questions in the test

TIME - 20MINS

1. State Ohm's law.
2. Explain what happens to the resistance of the resistor when the voltage across the resistor is increased?
3. If the resistance in a circuit is increased, what will be the effect of this change on the voltage from the power source (cell)?
4. What happens to the current in the circuit if the voltage is increased?

PART 2 -- POSTTEST

Please answer all questions in the test

TIME - 20MINS

1. State Ohm's law.
2. The voltage across a 4Ω resistor is 2V. What happens to the resistance of the resistor if the voltage across the resistor is increased to 4V?
3. A simple circuit having an effective resistance of 4Ω is supplied with a 4V voltage from a power source. If the resistance in a circuit is increased to 8Ω , what will be effect of this change on the voltage from the power source?
4. A 2Ω bulb is connected to a 2V power source. What happens to the current passing through the bulb if the voltage is increased 4V?

APPENDIX E

ELECTRICITY CONCEPTS TEST (ECT) FOR LESSON 5

PART 1 -- PRETEST

Please answer all questions in the test

TIME - 20MINS

- Three identical 1.5V cells in series with one connected in the wrong order is connected to a 1.5V bulb as shown below. Explain what happens to the bulb if the circuit is closed.

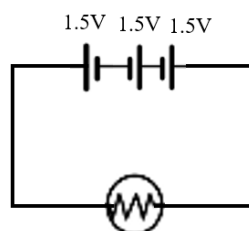

- Two resistors having resistances of 2Ω and 10Ω respectively are connected in series to a power source. Calculate the effective resistance.
- Two resistors having resistances of 2Ω and 4Ω respectively are connected in series to a power source. Three ammeters are connected at different points in the circuit. When the circuit is closed, the first ammeter reads $0.4A$. What is the reading of the third ammeter and explain why the ammeter read that value?
- Two identical bulbs are connected in series to a $6V$ power source. In another circuit, three identical bulbs are also connected to a $6V$ power source. When both circuits are closed, compare the brightness of two bulbs in the first circuit to the brightness of three bulbs in the second circuit. State and explain the reason behind the observation made.

PART 2 -- POSTTEST

Please answer all questions in the test

TIME - 20MINS

1. A bulb is connected as shown below using three identical 1.5.V cells in series, one of which is connected in the reverse. Describe what happens to the bulb when the circuit is shut off.

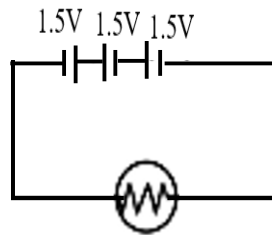

2. Two resistors having resistances of 4Ω and 12Ω respectively are connected in series to a power source. Find the effective resistance.
3. Two resistors having resistances of 2Ω and 4Ω respectively are connected in series to a power source. Three ammeters are connected at different points in the circuit. When the circuit is closed, the first ammeter reads 0.2A . What is the reading of the third ammeter and explain why the ammeter read that value?
4. Two identical bulbs are connected in series to a 8V power source. In another circuit, three identical bulbs are also connected to a 8V power source. When both circuits are closed, compare the brightness of two bulbs in the first circuit to the brightness of three bulbs in the second circuit. State and explain the reason behind the observation made.

APPENDIX F

ELECTRICITY CONCEPTS TEST (ECT) FOR LESSON 6

PART 1 -- PRETEST

Please answer all questions in the test

TIME - 20MINS

1. Three identical cells arranged in parallel is a connected to a bulb. If the emf of a cell is 2V. Find the pd across bulb.
2. Two resistors having resistances of 2Ω and 10Ω respectively are connected in parallel to a power source. Calculate the effective resistance.
3. Two resistors having resistances of $R_1= 10\Omega$ and $R_2=2\Omega$ respectively are connected in parallel to a power source of

as shown in the circuit below. Rank the currents at points x, y, and z from highest to the lowest.

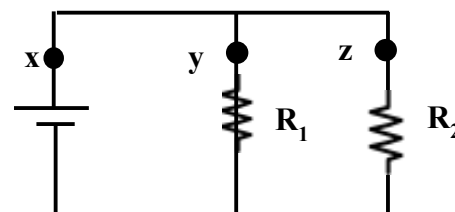

4. Explain why similar bulbs connected in parallel to a cell produce the same brightness but dissimilar bulbs produce varying brightness.

PART 2 -- POSTTEST

Please answer all questions in the test

TIME - 20MINS

- Two identical cells arranged in parallel is a connected to a parallel arrangement of two resistors with resistances 2Ω and 6Ω respectively as shown in the circuit diagram.

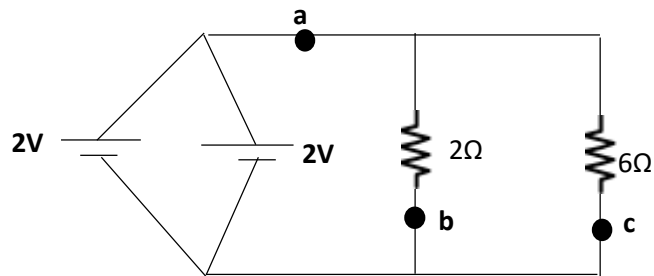

- Find the pd across the each of the resistors.
 - Calculate the effective resistance.
 - Rank the currents at points a, b, and c in the circuit from lowest. to the highest
- Explain why similar bulbs connected in parallel to a cell produce the same brightness but dissimilar bulbs produce varying brightness depending on their resistances.

APPENDIX G

STUDENTS ACTIVITY SHEET

Lesson One ----- Electrical Current

SECTION A: What do you know already

You will be provided with some test items to answer. Read the questions and provide the response that best answers the question on the blank sheet provided. Feel free to use calculators where necessary. You are encouraged to do independent work.

SECTION B Let's shake things up

Watch a PHET simulation on electrical current.

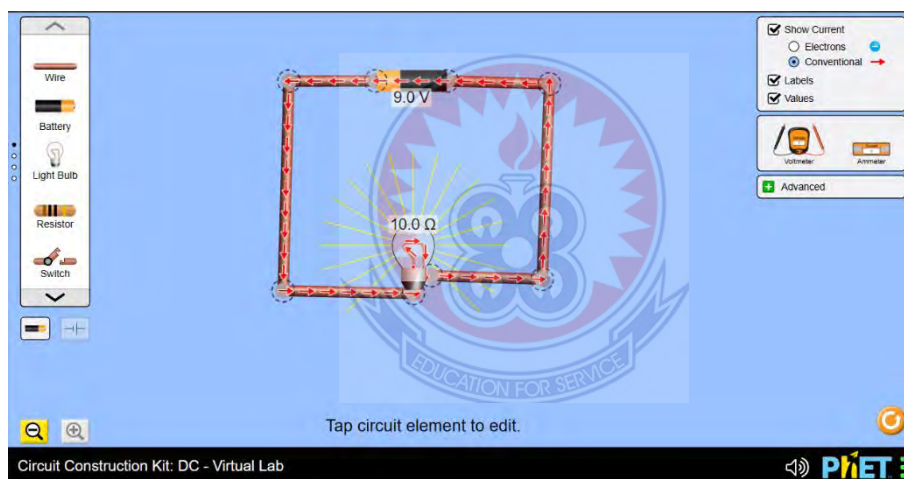

In your respective groups, discuss the simulation on electrical current. Feel free to manipulate the simulation where necessary.

SECTION C: Let's solve a problem

Consider the circuit diagram below diagram

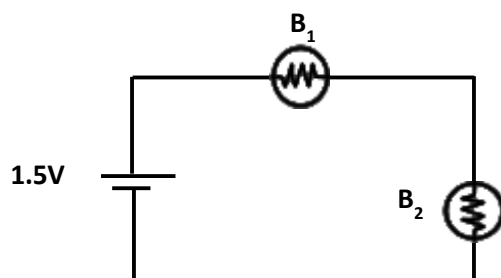

1. Redraw the circuit diagram above and add an ammeter at the appropriate point to measure the current in the circuit.
2. On the new diagram drawn, indicate the direction of the conventional current and electron flow.
3. If it takes $1\mu\text{s}$ for 30 electrons to pass a point in a circuit, what is the current at that point?

Section D: Let's wrap up

Part I (Concept)

You will be provided with some test items to answer. Read the questions and provide the response that best answers the question on the blank sheet provided. Feel free to use calculators where necessary. You are encouraged to do independent work.

Part II (Instruction)

Reflect over all that has happened in the instruction and answer the following questions.

1. To what extent do you think the instruction helped to change your conceptions about electric current?
2. How sure are you about the things you have learned and what is your evidence about it?
3. What are the strengths and weaknesses of the instruction?

LESSON TWO: Potential difference and E.M.F

SECTION A: What do you know already

You will be provided with some test items to answer. Read the questions and provide the response that best answers the question on the blank sheet provided. Feel free to use calculators where necessary. You are encouraged to do independent work.

SECTION B : Let's shake things up

Watch a video on the concept of E.M.F. and Potential difference.

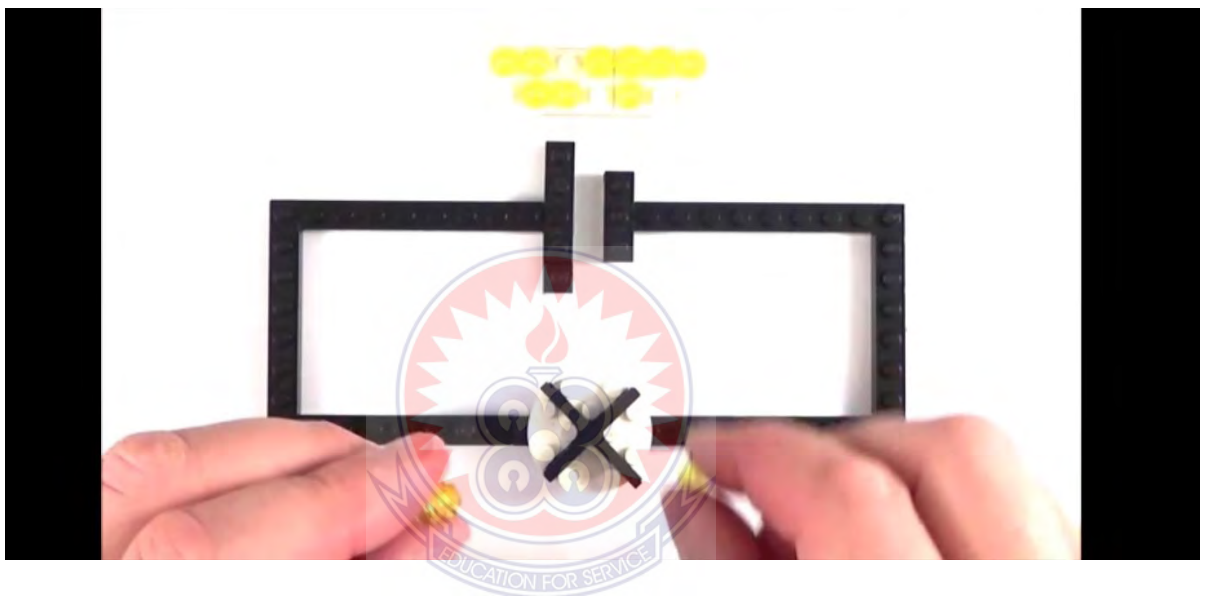

Source: <http://sharevideo1.com/v/djdYUXMyc0tzS1U=?t=ytb&f=sy>

In your respective groups, discuss the video watched.

SECTION C: Let's solve a problem _____

Solve the following questions.

1. Calculate the voltage of a battery if it supplies 300J of energy to 50C of charge.
2. Calculate the value of the charge if a 4 battery supplies 1500J of energy to the charge.

Section D: Let's wrap up _____

Part I (Concept)

You will be provided with some test items to answer. Read the questions and provide the response that best answers the question on the blank sheet provided. Feel free to use calculators where necessary. You are encouraged to do independent work.

Part II (Instruction)

Reflect over all that has happened in the instruction and answer the following questions.

1. To what extend do you think the instruction helped to change your conceptions about Pd and E.M.F.?
2. How sure are you about the things you have learned and what is your evidence about it?
3. What are the strengths and weaknesses of the instruction?

LESSON THREE: Resistance

SECTION A: What do you know already _____

You will be provided with some test items to answer. Read the questions and provide the response that best answers the question on the blank sheet provided. Feel free to use calculators where necessary. You are encouraged to do independent work.

SECTION B : Let's shake things up _____

Perform the activities below and note down your observation

1. Measure a 50cm length of thin copper wire and connect the ends of the wire to the probes of a multimeter.

Record the value of the resistance displayed.

.....

For same thin copper wire used earlier, measure a 100cm length and connect the ends of the wire to the probes of a multimeter. Record the new value of the resistance displayed.

Compare the two values of resistances and comment.

.....

Take a thin copper wire (smaller diameter) and thick copper wire(bigger diameter) and measure 50cm length respectively. Connect the ends of the thin copper wire and the ends of the thick copper wire both of the same length respectively to the probes of the multimeter. Record values of resistances for both wires respectively.

Resistance of the thin 50cm length copper wire =

Resistance of the thick 50cm length copper wire =

Compare the two values of resistances and comment

.....

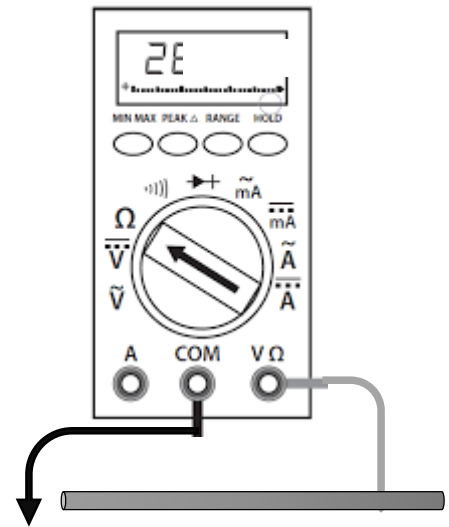

SECTION C: Let's solve a problem _____

Answer the following questions;

1. Calculate the length of wire of 1.0mm diameter and $5.0 \times 10^{-6} \Omega\text{m}$ resistivity that would have a resistance of 5.0Ω .
2. The electrical resistivity of a wire is $45 \times 10^{-8} \Omega\text{m}$. Calculate the resistance if the wire is 22.0m long and has diameter of 1.0mm.

Section D: Let's wrap up _____

Part I (Concept)

You will be provided with some test items to answer. Read the questions and provide the response that best answers the question on the blank sheet provided. Feel free to use calculators where necessary. You are encouraged to do independent work.

Part II (Instruction)

Reflect over all that has happened in the instruction and answer the following questions.

1. To what extent do you think the instruction helped to change your conceptions about electric resistance?
2. How sure are you about the things you have learned and what is your evidence about it?
3. What are the strengths and weaknesses of the instruction?

LESSON FOUR: Ohm's Law**SECTION A: What do you know already** _____

You will be provided with some test items to answer. Read the questions and provide the response that best answers the question on the blank sheet provided. Feel free to use calculators where necessary. You are encouraged to do independent work.

SECTION B: Let's shake things up _____

Play the Phet Interactive simulations on ohm's law and note down your observations.

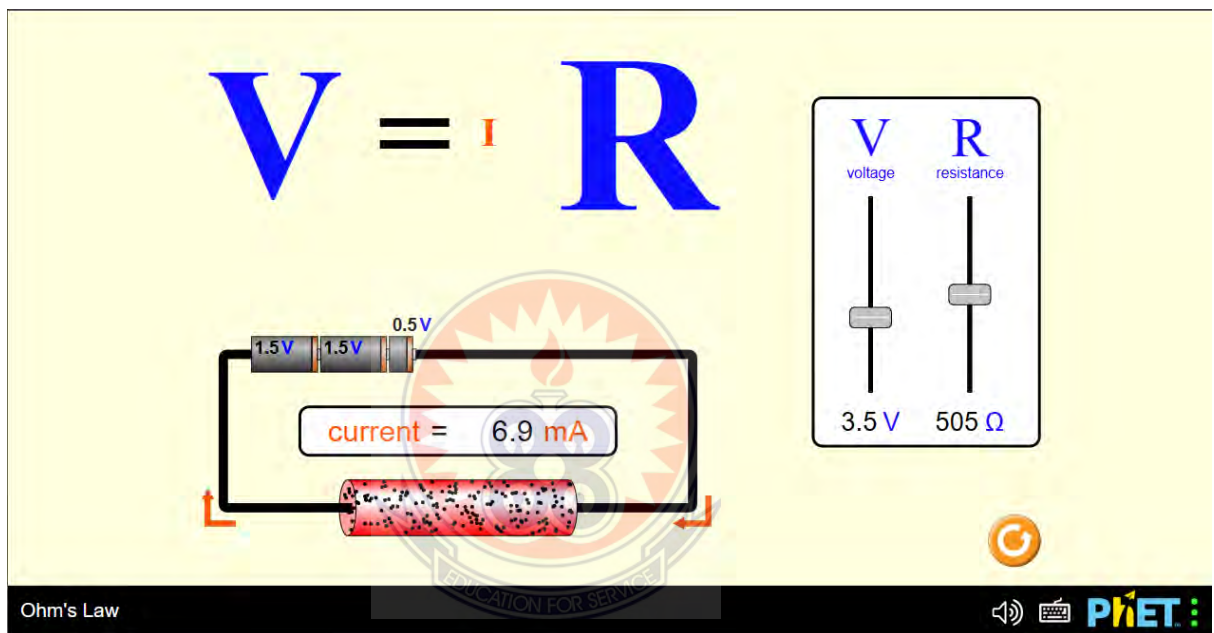

Move the voltage knob and then the resistance knob up and down respectively and observe what happens.

Briefly discuss the observations in your respective groups.

SECTION C: Let's solve a problem _____

Follow the instructions below to perform the experiment. Answer the questions on a graph sheet.

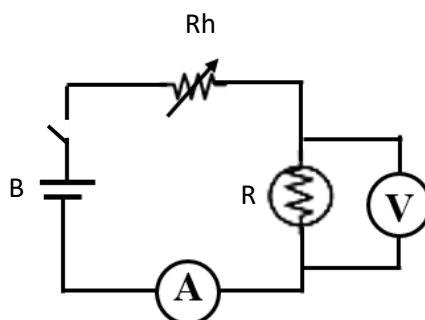

1. The circuit above consists of a battery B, a key K, a bulb R, a rheostat Rh, an ammeter A, a voltmeter V and connecting wires.
2. Connect the circuit as shown.
3. Set the rheostat Rh, so that it is as large as possible and then close the key K
4. Adjust the rheostat such that the voltmeter across bulb R reads 2.0V and record the corresponding ammeter reading.
5. Repeat the procedure for values of 2.2V, 2.4V, 2.6V and 2.8 V.
6. Tabulate the results as shown in the table below and evaluate the ratio of V and I.

V/V	I/A	$\frac{V}{I}/\Omega$
2.0		
2.2		
2.4		
2.6		
2.8		

7. What can be said about the results for the ratio of V and I from the table?

8. Plot a graph of V on the vertical axis against I on the horizontal axis.
9. Determine the slope of the graph.
10. Compare the value of the slope to the results for the ratio of V and I from the table. What conclusions can you draw from the experiment?

Section D: Let's wrap up_____

Part I (Concept)

You will be provided with some test items to answer. Read the questions and provide the response that best answers the question on the blank sheet provided. Feel free to use calculators where necessary. You are encouraged to do independent work.

Part II (Instruction)

Reflect over all that has happened in the instruction and answer the following questions.

1. To what extent do you think the instruction helped to change your conceptions about Ohms Law?
2. How sure are you about the things you have learned and what is your evidence about it?
3. What are the strengths and weaknesses of the instruction?

LESSON FIVE: Series connection of electrical components**SECTION A: What do you know already** _____

You will be provided with some test items to answer. Read the questions and provide the response that best answers the question on the blank sheet provided. Feel free to use calculators where necessary. You are encouraged to do independent work.

SECTION B : Let's shake things up _____

Perform the activity below and discuss your observations your respective groups over the questions that follow.

- A. Connect the circuit as shown below. What is your observation.

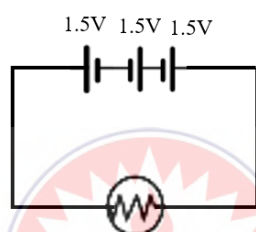

- B.

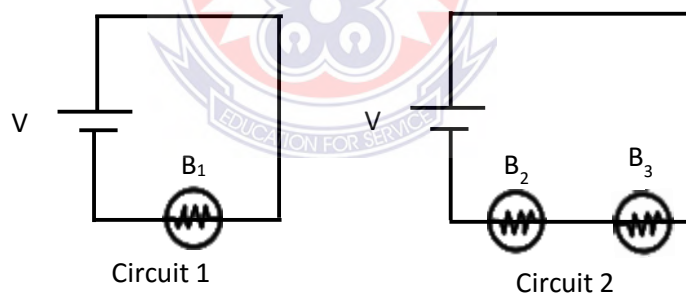

- i. Using your materials, set up Circuit 1.
- ii. Take note of the brightness of bulb B₁
- iii. Using your materials, set up Circuit 2.
- iv. Take note of the brightness of bulb B₂ and B₃ in Circuit 2.
- v. Which circuit had the brightest bulb, Circuit 1 or Circuit 2?
Why is this so?
- vi. While Circuit 2 is still closed, unscrew bulb B₂ in Circuit 2.
What was your observation and why was this so?

- vii. Connect another bulb B_4 in series to B_2 and B_3 in Circuit 2. What will be the brightness of the bulbs in Circuit 2?

SECTION C: Let's solve a problem

The following circuit shows three resistors, A, B and C, connected in series. The potential difference across A and B are given as $V_A = 2.0 \text{ V}$ and $V_B = 4.0 \text{ V}$. Given that the e.m.f. of the battery is 12.0 V ,

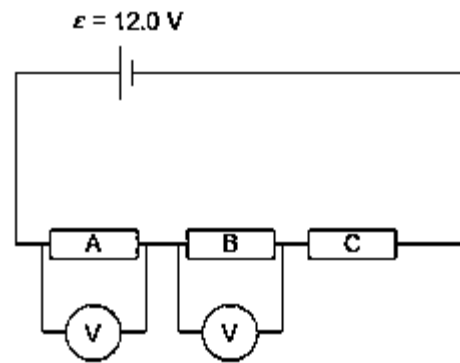

- a) Find the potential difference across resistor C.
- b) If the current in the circuit is 0.5 A , calculate the resistances for resistor A, B and C.
- c) Calculate the effective resistance in the circuit.

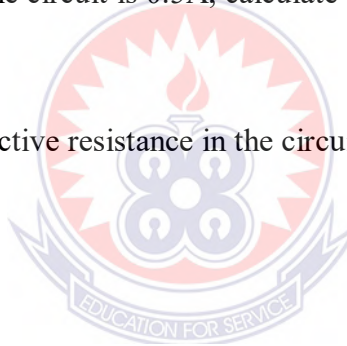

Section D: Let's wrap up _____**Part I (Concept)**

You will be provided with some test items to answer. Read the questions and provide the response that best answers the question on the blank sheet provided. Feel free to use calculators where necessary. You are encouraged to do independent work.

Part II (Instruction)

Reflect over all that has happened in the instruction and answer the following questions.

1. To what extent do you think the instruction helped to change your conceptions about series connection of electrical components?
2. How sure are you about the things you have learned and what is your evidence about it?
3. What are the strengths and weaknesses of the instruction?

LESSON SIX: Parallel connection of electrical components**SECTION A: What do you know already** _____

You will be provided with some test items to answer. Read the questions and provide the response that best answers the question on the blank sheet provided. Feel free to use calculators where necessary. You are encouraged to do independent work.

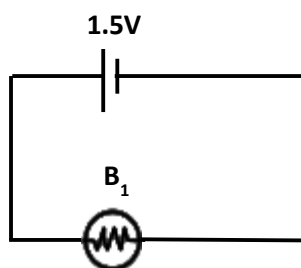
SECTION B : Let's shake things up _____

Circuit 1

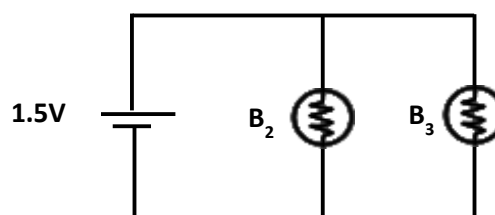

Circuit 2

1. Connect the circuits as shown above.
2. Which circuit had the brightest bulb(s), Circuit 1 or Circuit 2? Why is this so?
3. Add an additional bulb in parallel with the two bulbs already in circuit 2. What happens to the brightness of the bulbs?
4. Unscrew bulb B₂ in Circuit 2. What is your observation?
5. Connect an additional cell in parallel to the cell in circuit 2. What happened to the brightness of bulbs in circuit 2?

SECTION C: Let's solve a problem

Teacher asks students to solve the following questions in their groups.

Consider the circuits A and B. St

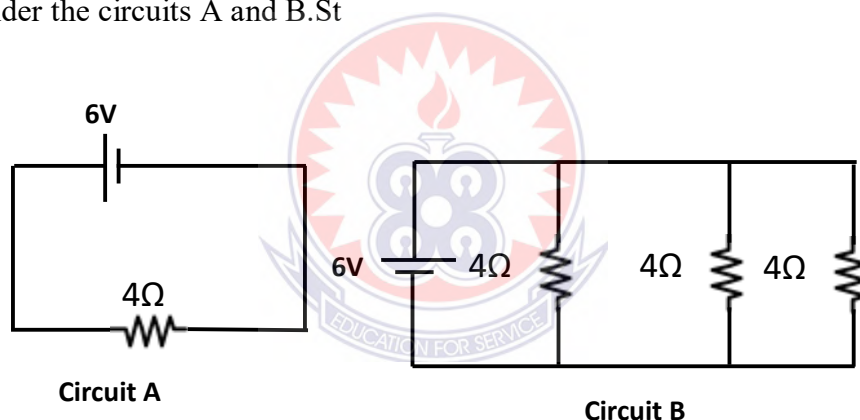

1. How does the current through the one resistor in circuit A, compare to the current through each resistor in circuit B?
2. How does the sum of the currents through the three bulbs in circuit B compare to current from the battery in circuit A?
3. Explain how is the current out of the battery (and back into it) is affected by adding resistors in parallel?
4. If the resistors were light bulbs, how does the brightness of each bulb in circuit B compare to the brightness of the single bulb in circuit A?
5. How is the resistance of a circuit affected by adding additional pathways?

Section D: Let's wrap up_____

Part I (Concept)

You will be provided with some test items to answer. Read the questions and provide the response that best answers the question on the blank sheet provided. Feel free to use calculators where necessary. You are encouraged to do independent work.

Part II (Instruction)

Reflect over all that has happened in the instruction and answer the following questions.

1. To what extent do you think the instruction helped to change your conceptions about electric current?
2. How sure are you about the things you have learned and what is your evidence about it?
3. What are the strengths and weaknesses of the instruction?

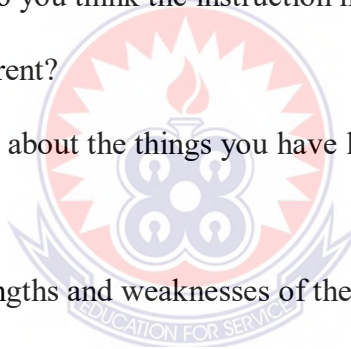

APPENDIX H
UNIVERSITY OF EDUCATION, WINNEBA
DEPARTMENT OF SCIENCE EDUCATION
SEMI-STRUCTURED FACE-TO-FACE GUIDE ON THE
IMPLEMENTATION OF CONCEPTUAL CHANGE APPROACH TO
TEACHING AND ITS EFFECT ON STUDENTS' ACADEMIC
PERFORMANCE

The study aims to determine the effects of implementing a conceptual change approach to teaching physics on students' academic performance.

INSTRUCTIONS

The interview guide is designed to seek the thoughts, knowledge, and attitudes on the teaching strategy implemented and its effects on students' academic performance.

This is to enable the researcher gather data for his MPhil in Science Education dissertation. I need your cooperation to answer these questions and each item as honestly as possible. Your experiences, views and knowledge are greatly appreciated and will be treated with confidentiality.

This is purely an academic exercise and your responses and comments to the questions are important to the outcome of the study. Moreover, your anonymity is guaranteed.

The entire discussions will be tape-recorded but no respondent will be identified by name on the tape. Data collected will be considered confidential, and no one else except the researcher and the respondent will have access to interview responses. The study will present only minimal risk to those who will partake because data will be collected and communicated using the anonymity of a pseudonym. Your name will not appear on any document where information is recorded. Data will be recorded with a pseudonym of your choice. Your participation in the study will help bring to light the effects of implementing a conceptual change approach to teaching on students' performance. The interview will last 10 minutes to 15 minutes approximately.

- I. What is your general feeling about the intervention used in the electricity concept
- II. How has your performance been since you were introduced to the teaching strategy implemented in your lessons?
 - a. How well do you answer questions after the exposure to the teaching strategy?
 - b. How has your level of participation been after the exposure to the teaching strategy?
- III. Was there a point in your understanding, where you had idea(s) about a particular topic treated that was scientifically wrong?
 - a. What are those ideas or conceptions?
 - b. Did that idea(s) change after you were taught with the teaching strategy used in the lessons?

**YOUR CONTRIBUTION TO THIS STUDY IS HIGHLY APPRECIATED
THANK YOU FOR YOUR COOPERATION**

APPENDIX I

RUBRICS FOR ELECTRICITY CONCEPTS TEST (ECT) FOR LESSON 1

Question	Rubrics
<p>1. Define the term electric current</p>	<p>1: Inaccurate - Provides a definition that is incorrect or unrelated to electric current.</p> <p>Criteria for 1: Student provides a definition that misrepresents electric current, such as stating that electric current is the sensation you feel when you touch a battery.</p> <p>2: Partially correct - Offers a somewhat accurate definition but lacks clarity or completeness.</p> <p>Criteria for 2: Student provides a definition that electric current refers to the flow of electricity in a conductor instead of electric charges.</p> <p>3: Correct - Provides a clear and accurate definition of electric current.</p> <p>Criteria for 3: Student offers a definition that accurately defines electric current as the flow of electric charge carriers (typically electrons) through a</p>

	<p>conductor per unit of time, usually measured in amperes (A).</p>
<p>2. What is meant by the term short circuit?</p>	<p>1: Inaccurate - Provides an explanation that is incorrect or unrelated to a short circuit.</p> <p>Criteria for 1: Student presents an explanation that misinterprets or fails to address the concept of a short circuit, such as defining it as a type of electrical connector.</p> <p>2: Partially correct - Offers an explanation that is somewhat accurate but lacks clarity or completeness.</p> <p>Criteria for 2: Student explaining that short circuit is a situation where current flows through a circuit with short wires.</p> <p>3: Correct - Provides a clear and accurate explanation of what a short circuit is.</p> <p>Criteria for 3: Student offers a definition that accurately defines a short circuit as an unintended low-resistance path between two points in a circuit, typically resulting in excessive current</p>

	<p>flow and potential damage to components or hazards like fire.</p>
<p>3. What is the difference between conventional current and electron flow</p>	<p>1: Incorrect - Provides an inaccurate or unrelated explanation of the difference. Criteria for 1: Student must provide an incorrect explanation, such as stating that conventional current is the flow of electrons or that electron flow refers to the movement of positive charges.</p> <p>2: Partially correct - Offers an explanation that is somewhat accurate but lacks clarity or completeness in distinguishing between conventional current and electron flow. Criteria for 2: Student may correctly mention the flow of charges but lacks clarity in distinguishing the direction or nature of charges involved. For example, stating that conventional current flows from the negative terminal to the positive terminal without clarifying the role of electrons.</p> <p>3: Correct - Provides a clear and accurate explanation highlighting the</p>

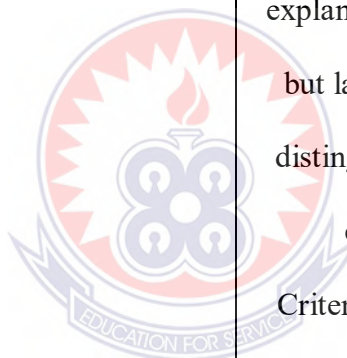

	<p>differences between conventional current and electron flow.</p> <p>Criteria for 3: Student clearly explains that conventional current assumes positive charges flow from the positive terminal to the negative terminal, while electron flow involves the movement of negatively charged electrons from the negative terminal to the positive terminal.</p>
<p>4. If the charges passing through a particular point in a circuit in time t are tripled, what happens to the current?</p>	<p>1: Incorrect - Provides an inaccurate or unrelated explanation of the relationship between charges and current.</p> <p>Criteria for 1: Student must provide an incorrect explanation, such as stating that current decreases when charges are tripled or that current remains the same regardless of changes in charge.</p> <p>2: Partially correct - Offers an explanation that is somewhat accurate but lacks clarity or completeness in describing the relationship between charges and current.</p> <p>Criteria for 2: Student may correctly mention that current increases when</p>

	<p>charges are tripled but lacks clarity in explaining the exact relationship or factors involved.</p> <p>3: Correct - Provides a clear and accurate explanation of the relationship between charges and current.</p> <p>Criteria for 3: Student clearly explains that when the charges passing through a particular point in a circuit are tripled, the current also triples, as current is directly proportional to charge flow.</p>
<p>5. A student stated that “an electric bulb consumes the charges that enter it to brighten up therefore the current flowing back to the cell reduces”. What can you say about the statement made by the students?</p>	<p>1: Incorrect - Provides an inaccurate or unrelated explanation of the relationship between electric bulbs, charges, and current.</p> <p>Criteria for 1: Student must provide an incorrect explanation, such as agreeing with the statement or stating that the current increases as the bulb consumes charges.</p> <p>2: Partially correct - Offers an explanation that is somewhat accurate but lacks clarity or completeness in describing the relationship between electric bulbs, charges, and current.</p>

	<p>Criteria for 2: Student may acknowledge that electric bulbs does not consume charges to brighten up but fails to fully explain the relationship between charge consumption and current flow.</p> <p>3: Correct - Provides a clear and accurate explanation of the statement made by the student.</p> <p>Criteria for 3: Student explains that while electric bulbs do not consume charges to produce light, it's the electrical energy carried by the charges that is used up. Therefore, the charges that enters the bulb is the ssame us the charges that leaves the bulb.</p>
<p>6. With the aid of a diagram, describe how you would connect an ammeter in a circuit to measure the current.</p>	<p>1: Incorrect - Diagram and/or explanation is inaccurate or does not show proper connection of the ammeter.</p> <p>Criteria for 1: Student provides an incorrect diagram or explanation, showing the ammeter connected incorrectly in the circuit.</p>

	<p>2: Partially correct - Diagram may be somewhat accurate but lacks clarity or explanation is incomplete.</p> <p>Criteria for 2: Student presents a diagram that somewhat accurately shows the connection of the ammeter but lacks clarity in the explanation or omits important details.</p> <p>3: Correct - Provides a clear and accurate diagram with accompanying explanation demonstrating the correct connection of the ammeter in the circuit.</p> <p>Criteria for 3: Student offers a clear and accurate diagram showing the correct placement of the ammeter in series with the circuit components, along with a detailed explanation of the procedure and the role of the ammeter in measuring current.</p>
--	--

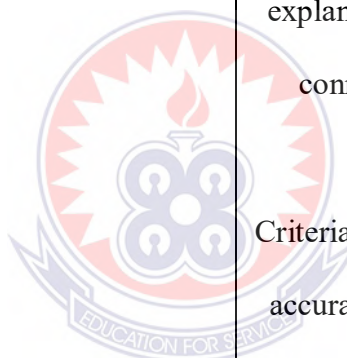

APPENDIX J**RUBRICS FOR ELECTRICITY CONCEPTS TEST (ECT) FOR LESSON 2**

Question	Rubrics
<p>1. The potential difference and E.M.F. are the same. What is your take on this statement?</p>	<p>1: Inaccurate - Provides an explanation that is incorrect or fails to distinguish between potential difference and electromotive force (E.M.F.).</p> <p>Criteria for 1: Student incorrectly asserts that potential difference and E.M.F. are identical without addressing their distinctions or providing inaccurate definitions for each term.</p> <p>2: Partially correct - Offers an explanation that recognises a relationship between potential difference and E.M.F. but lacks clarity or completeness.</p> <p>Criteria for 2: Student acknowledges that there is differences between potential difference and E.M.F. but may not fully distinguish between the two or provide a comprehensive explanation of their relationship.</p>

	<p>3: Correct - Provides a clear and accurate explanation distinguishing between potential difference and E.M.F.</p> <p>Criteria for 3: Student mentions that there is a difference between E.M.F and pd and offers a clear explanation differentiating potential difference (voltage drop across a component due to the flow of current) from E.M.F. (the maximum potential difference provided by a source, such as a battery) .</p> <p>Similarly students may state that EMF is independent of the resistance in the circuit whiles pd is dependent.</p>
<p>2. The charge that flows in the circuit originates from the electric cells. What is your take on this statement?</p>	<p>1: Inaccurate - Provides an explanation that is incorrect or fails to consider other sources of charge in a circuit.</p> <p>Criteria for 1: Student incorrectly asserts that all charge in a circuit originates solely from electric cells without acknowledging other sources such as free electrons in the conductive part (wires).</p>

	<p>2: Partially correct - Acknowledges the role of electric cells in providing charge but lacks clarity or completeness.</p> <p>Criteria for 2: Student recognizes the contribution of electric cells to the flow of charge but may not fully address the presence of other charge sources or their roles in the circuit.</p> <p>3: Correct - Provides a clear and accurate explanation of the origin of charge in a circuit.</p> <p>Criteria for 3: Student offers a comprehensive explanation acknowledging that while electric cells contribute to charge flow in a circuit, the charges that flows in the circuit are already existent in the wires (conductive parts). For whatever number of electric charges released at the negative terminal of the cell, same number enters the cell from the positive terminal such that the net charge in the circuit remains the same. So the cell helps the charges already in the wires to move.</p>
--	---

<p>3. Calculate the voltage of a battery if it supplies 4Joules of energy to 3C of charge.</p>	<p>1: Inaccurate - Provides an incorrect calculation or uses the wrong formula. Criteria for 1: Student incorrectly calculates the voltage or applies an inappropriate formula to the given scenario.</p> <p>2: Partially correct - Makes an attempt at calculation but contains errors or lacks clear explanation. Criteria for 2: Student attempts to calculate the voltage but may make computational errors.</p> <p>3: Correct - Accurately calculates voltage using the correct formula and provides a clear solution. Criteria for 3: Student correctly applies the formula $V = W/Q$ (voltage equals energy divided by charge) to calculate the voltage, substitutes the given values into the formula, and provides a clear solution, resulting in the accurate determination of the battery's voltage. $V = 4/3 = 1.33V$</p>
<p>4. With the aid of a diagram, describe how you would</p>	<p>1: Inaccurate - Diagram and/or explanation is inaccurate or does not</p>

<p>connect a voltmeter in a circuit to measure the voltage</p>	<p>show proper connection of the voltmeter.</p> <p>Criteria for 1: Student provides an incorrect diagram or explanation that does not accurately depict the connection of the voltmeter in the circuit.</p> <p>2: Partially correct - Diagram may be somewhat accurate but lacks clarity or explanation is incomplete.</p> <p>Criteria for 2: Student presents a diagram that somewhat accurately shows the connection of the voltmeter but lacks clarity in the explanation or omits important details.</p> <p>3: Correct - Provides a clear and accurate diagram with accompanying explanation demonstrating the correct connection of the voltmeter in the circuit.</p> <p>Criteria for 3: Student offers a clear and accurate diagram showing the correct placement of the voltmeter in parallel with the component across which the voltage is to be measured, along with a</p>
--	--

	detailed explanation of the procedure and the role of the voltmeter in measuring voltage
--	--



APPENDIX K

ELECTRICITY CONCEPTS TEST (ECT) FOR LESSON 3

Question	Rubrics
<p>1. Define the term electrical resistance.</p>	<p>1: Inaccurate - Provides an incorrect or unrelated definition of electrical resistance.</p> <p>Criteria for 1: Student offers a definition that misinterprets or fails to address the concept of electrical resistance, such as stating that it refers to the flow of electrons through a circuit.</p> <p>2: Partially correct - Offers a definition that is somewhat accurate but lacks clarity or completeness.</p> <p>Criteria for 2: Student provides a definition that electrical resistance is the opposition to the flow of electricity.</p> <p>3: Correct - Provides a clear and accurate definition of electrical resistance.</p> <p>Criteria for 3: Student offers a definition that accurately describes electrical resistance as the measure of opposition</p>

	<p>to the flow of electric current in a material.</p>
<p>2. A metallic conductor has resistance R. If the conductor is stretched to a new length greater the original, what will be the effect on the resistance of the conductor?</p>	<p>1: Inaccurate - Provides an incorrect or unrelated explanation of the relationship between length and resistance.</p> <p>Criteria for 1: Student offers an explanation that misinterprets or fails to address the relationship between the length of a conductor and its resistance, such as stating that the resistance decreases when the conductor is stretched.</p> <p>2: Partially correct - Offers an explanation that is somewhat accurate but lacks clarity or completeness.</p> <p>Criteria for 2: Student provides an answer that the resistance will change but failed to explain the specific effect of stretching on resistance.</p> <p>3: Correct - Provides a clear and accurate explanation of the effect of stretching on the resistance of the conductor.</p> <p>Criteria for 3: Student accurately explains that increasing the length of a</p>

	<p>conductor results in an increase in resistance. This is due to the increased length providing more material for the electrons to travel through, thereby increasing the opposition to the flow of current</p>
<p>3. A metallic conductor has resistance R. If the cross-sectional area A of the conductor is increased without increasing the original length, what will be the effect on the resistance of the conductor?</p>	<p>1: Inaccurate - Provides an incorrect or unrelated explanation of the relationship between cross-sectional area and resistance.</p> <p>Criteria for 1: Student offers an explanation that misinterprets or fails to address the relationship between the cross-sectional area of a conductor and its resistance, such as stating that increasing the area decreases the resistance.</p> <p>2: Partially correct - Offers an explanation that is somewhat accurate but lacks clarity or completeness.</p> <p>Criteria for 2: Student mentions that electrical resistance will decrease without linking it to relationship between cross-sectional area and resistance.</p>

	<p>3: Correct - Provides a clear and accurate explanation of the effect of increasing the cross-sectional area on the resistance of the conductor.</p> <p>Criteria for 3: Student accurately explains that increasing the cross-sectional area of a conductor decreases its resistance. This is because a larger cross-sectional area allows more space for charge carriers to flow, reducing their density and subsequently lowering the resistance to current flow.</p>
<p>4. How does increase in temperature affects the resistance of a metallic conductor?</p>	<p>1: Inaccurate - Provides an incorrect or unrelated explanation of the relationship between temperature and resistance.</p> <p>Criteria for 1: Student stating that resistance decreases with temperature increase.</p> <p>2: Partially correct - Offers an explanation that is somewhat accurate but lacks clarity or completeness.</p> <p>Criteria for 2: Student mentions that resistance will increase but failed in explaining the specific effect of temperature increase on resistance.</p>

	<p>3: Correct - Provides a clear and accurate explanation of how an increase in temperature affects the resistance of a metallic conductor.</p> <p>Criteria for 3: Student accurately explains that an increase in temperature generally increases the resistance of a metallic conductor. This is because as the temperature rises, the atoms in the conductor vibrate more vigorously, increasing collisions with the charge carriers (usually electrons), thereby impeding their flow and increasing resistance.</p>
--	---



APPENDIX L

RUBRICS ELECTRICITY CONCEPTS TEST (ECT) FOR LESSON 4

Question	Rubrics
1. State Ohm's law.	<p>1: Inaccurate - Provides an incorrect or unrelated statement.</p> <p>Criteria for 1: Student presents a statement that misinterprets or fails to represent Ohm's law, such as stating an incorrect formula or unrelated information.</p> <p>2: Partially correct - Offers a statement that is somewhat accurate but lacks clarity or completeness.</p> <p>Criteria for 2: Student provides a statement that partially describes Ohm's law but may lack clarity in expressing all its components or fails to mention the relationship between voltage, current, and resistance.</p> <p>3: Correct - Provides a clear and accurate statement of Ohm's law.</p> <p>Criteria for 3: Student accurately states Ohm's law as: "The current passing through a conductor between two points is directly proportional to the voltage</p>

	<p>across the two points, provided the temperature remains constant.</p>
<p>2. Explain what happens to the resistance of the resistor when the voltage across the resistor is increased?</p>	<p>1: Inaccurate - Provides an incorrect or unrelated explanation of the relationship between voltage and resistance.</p> <p>Criteria for 1: Student presents an explanation that misinterprets or fails to address the relationship between voltage and resistance, such as stating that resistance increases when voltage decreases.</p> <p>2: Partially correct - Offers an explanation that is somewhat accurate but lacks clarity or completeness.</p> <p>Criteria for 2: Student states that the resistance remains the same but fails to explain the specific effect of increasing voltage on resistance.</p> <p>3: Correct - Provides a clear and accurate explanation of how increasing voltage affects the resistance of the resistor.</p> <p>Criteria for 3: Student accurately explains that when the voltage across a resistor increases, the resistance of the</p>

	<p>resistor remains constant, assuming the temperature remains constant. This is in accordance with Ohm's law, which states that resistance (R) is constant for a given conductor at a constant temperature, regardless of the applied voltage.</p>
<p>3. If the resistance in a circuit is increased, what will be the effect of this change on the voltage from the power source (cell)?</p>	<p>1: Inaccurate - Provides an incorrect or unrelated explanation of the relationship between resistance and voltage.</p> <p>Criteria for 1: Student presents an explanation that misinterprets or fails to address the relationship between resistance and voltage, such as stating that increasing resistance decreases voltage.</p> <p>2: Partially correct - Offers an explanation that is somewhat accurate but lacks clarity or completeness.</p> <p>Criteria for 2: Student mentions that the voltage of the cell remains the same but fails to explain why it remains so.</p> <p>3: Correct - Provides a clear and accurate explanation of how increasing</p>

	<p>resistance does not after the voltage from the power source (cell).</p> <p>Criteria for 3: Student accurately explains that the voltage of the cell is independent of resistance in the circuit. in a circuit is increased. Thus increasing the resistance does not affect the voltage of the cell.</p>
<p>4. What happens to the current in the circuit if the voltage is increased?</p>	<p>1: Inaccurate - Provides an incorrect or unrelated explanation of the relationship between voltage and current.</p> <p>Criteria for 1: Student presents an explanation that misinterprets or fails to address the relationship between voltage and current, such as stating that current decreases when voltage increases.</p> <p>2: Partially correct - Offers an explanation that is somewhat accurate but lacks clarity or completeness.</p> <p>Criteria for 2: Student mentions that the current increases without linking it to partially describes the relation between voltage, current and resistance.</p>

	<p>3: Correct - Provides a clear and accurate explanation of how increasing voltage affects the current in the circuit.</p> <p>Criteria for 3: Student accurately explains that if the voltage in a circuit is increased, the current in the circuit will also increase, provided that the resistance remains constant. This is in accordance with Ohm's law, which states that current (I) is directly proportional to voltage (V) when resistance (R) is constant, expressed by the formula $I = V/R$. Alternatively, if resistance increases due to a change in the circuit, the current will decrease to maintain a constant voltage-current relationship.</p>
--	---

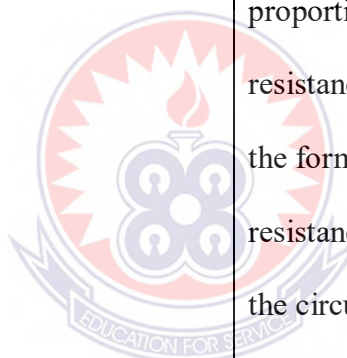

APPENDIX M

RUBRICS FOR ELECTRICITY CONCEPTS TEST (ECT) FOR LESSON 5

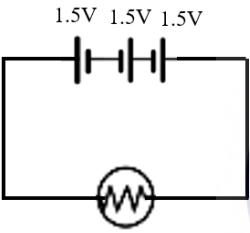
Question	Rubrics
<p>1. Three identical 1.5v cells in series with one connected in the wrong order is connected to a 1.5v bulb as shown below.</p> <p>Explain what happens to the bulb if the circuit is closed.</p> 	<p>1: Inaccurate - Provides an incorrect explanation or no response to the happenings in the bulb</p> <p>Criteria for 1: Student indicating that the bulb will not light.</p> <p>2: Partially correct - Offers an explanation that is somewhat accurate but lacks clarity or completeness.</p> <p>Criteria for 2: Student mentions that the bulb will light up without explaining why it does so or overlooks the role of the reverse cell in setting the net voltage to 1.5v</p> <p>3: Correct - Provides a clear and accurate explanation of what happens to the bulb if the circuit is closed with the cells connected in series, including one connected in the wrong order.</p> <p>Criteria for 3: Student accurately explains that the bulb will light up because the reverse- connected cell cancels out the voltage of other cells,</p>

	<p>resulting in a net voltage of 1.5v, which is sufficient to power the 1.5v bulb.</p>
<p>2. Two resistors having resistances of 2Ω and 10Ω respectively are connected in series to a power source. Calculate the effective resistance.</p>	<p>1: Inaccurate - Provides an incorrect calculation or uses the wrong formula. Criteria for 1: Student incorrectly calculates the effective resistance or applies an inappropriate formula to the given scenario.</p> <p>2: Partially correct - Makes an attempt at calculation but contains errors or lacks clear explanation. Criteria for 2: Student attempts to calculate the effective resistance but may make computational errors or fail to provide a thorough explanation of the steps involved.</p> <p>3: Correct - Accurately calculates the effective resistance using the correct formula and provides a clear solution. Criteria for 3: Student correctly applies the formula for calculating the effective resistance of resistors in series ($R = R_1 + R_2$) to calculate the effective resistance, substitutes the given resistance values into the formula, and</p>

	<p>provides a clear solution, resulting in the accurate determination of the total resistance (R) as $R = 12\Omega$</p>
<p>3. Two resistors having resistances of 2Ω and 4Ω respectively are connected in series to a power source. Three ammeters are connected at different points in the circuit. When the circuit is closed, the first ammeter reads $0.4A$. What is the reading of the third ammeter and explain why the ammeter read that value?</p>	<p>1: Inaccurate - Provides an incorrect or unrelated explanation of the current distribution in the circuit.</p> <p>Criteria for 1: Student presents an explanation that misinterprets or fails to address the distribution of current in the circuit, such as stating that the third ammeter reads a value greater than the first ammeter's reading without a valid reason.</p> <p>2: Partially correct - Offers an explanation that is somewhat accurate but lacks clarity or completeness.</p> <p>Criteria for 2: Student mentions $0.4A$ as the reading of the third ammeter without giving any specific reason for the third ammeter's reading.</p> <p>3: Correct - Provides a clear and accurate explanation of the reading of the third ammeter based on the distribution of current in the circuit.</p>

	<p>Criteria for 3: Student accurately explains that the reading of the third ammeter is also 0.4A. In a series circuit, the current remains constant throughout the circuit. Therefore, the same current measured by the first ammeter will also be measured by the third ammeter. This is because the total current flowing through the circuit is determined by the power source and the total resistance of the circuit, which remains the same regardless of where the ammeter is placed in the circuit</p>
<p>4. Two identical bulbs are connected in series to a 6V power source. In another circuit, three identical bulbs are also connected to a 6V power source. When both circuits are closed, compare the brightness of two bulbs in the first circuit to the brightness of three bulbs in the second circuit. State and explain the reason behind the observation made.</p>	<p>1: Inaccurate - Provides an incorrect or unrelated explanation of the brightness comparison.</p> <p>Criteria for 1: Student presents an explanation that misinterprets or fails to address the factors influencing the brightness comparison, such as stating that the bulbs in the second circuit are brighter due to their higher resistance.</p> <p>2: Partially correct - Offers an explanation that is somewhat accurate but lacks clarity or completeness.</p>

	<p>Criteria for 2: Student mentions that the bulbs in circuit 1 will be brighter but fails to explain the specific reason for the observed difference.</p> <p>3: Correct - Provides a clear and accurate explanation of the observed brightness comparison.</p> <p>Criteria for 3: Student accurately explains that the bulbs in the first circuit (with two bulbs in series) will be brighter compared to the bulbs in the second circuit (with three bulbs in series). This is because in a series circuit, the total voltage supplied by the power source is divided among the bulbs. With two bulbs in the first circuit, each bulb receives a higher voltage compared to the three bulbs in the second circuit, resulting in a brighter illumination. Additionally, each bulb in the second circuit has a higher resistance compared to the bulbs in the first circuit, further reducing the current flow and thus dimming the bulbs.</p> <p>Therefore, the bulbs in the first circuit</p>
--	---

	will appear brighter due to the higher voltage across each bulb.
--	--



APPENDIX N

RUBRICS FOR ELECTRICITY CONCEPTS TEST (ECT) FOR LESSON 6

Question	Rubrics
<p>1. Three identical cells arranged in parallel is a connected to a bulb. If the emf of a cell is 2V. Find the pd across bulb.</p>	<p>1: Inaccurate - Provides an incorrect calculation or uses the wrong formula.</p> <p>Criteria for 1: Student incorrectly gives no response or applies an inappropriate formula to the given scenario.</p> <p>2: Partially correct - Makes an attempt at calculation but contains errors or lacks clear explanation.</p> <p>Criteria for 2: Student mentions that the pd across the bulb is 2v but fails to explain why it is so.</p> <p>3: Correct - Accurately calculates the potential difference using the correct formula and provides a clear solution.</p> <p>Criteria for 3: Student correctly applies the principle that in parallel connection, the potential difference across each component is equal to the EMF of the cells. Therefore, the</p>

	<p>potential difference across the bulb is 2V, as each cell contributes its full EMF to the circuit.</p>
<p>2. Two resistors having resistances of 2Ω and 10Ω respectively are connected in parallel to a power source. Calculate the effective resistance.</p>	<p>1: Inaccurate - Provides an incorrect calculation or uses the wrong formula.</p> <p>Criteria for 1: Student incorrectly calculates the effective resistance or applies an inappropriate formula to the given scenario.</p> <p>2: Partially correct - Makes an attempt at calculation but contains errors.</p> <p>Criteria for 2: Student correctly writes the formula.</p> $\frac{1}{R} = \frac{1}{R_1} + \frac{1}{R_2}$ <p>to calculate the effective resistance but may make computational errors</p> <p>3: Correct - Accurately calculates the effective resistance using the correct formula and provides a clear solution.</p> <p>Criteria for 3: Student correctly applies the formula for calculating</p>

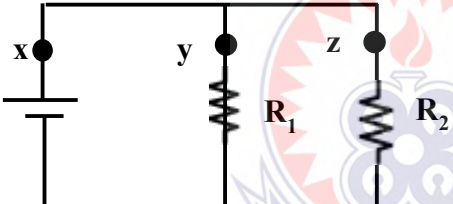
	<p>the effective resistance of resistors in parallel</p> $\left(\frac{1}{R} = \frac{1}{R_1} + \frac{1}{R_2}\right)$ <p>to calculate the effective resistance, substitutes the given resistance values into the formula, and provides a clear solution, resulting in the accurate determination of the total resistance. $R = 1.67 \Omega$</p>
<p>3. Two resistors having resistances of</p>  <p>$R_1 = 10\Omega$ and $R_2 = 2\Omega$ respectively are connected in parallel to a power source of as shown in the circuit below. Rank the currents at points x, y, and z from highest to the lowest.</p>	<p>1: Inaccurate - Provides an incorrect ranking of the currents or no response</p> <ul style="list-style-type: none"> Criteria for 1: Student incorrectly ranks the currents passing through the components as $z > y > x$ or $y > x > z$ <p>2: Partially correct - Ranks the currents but contains errors or lacks clear explanation.</p> <ul style="list-style-type: none"> Criteria for 2: Student ranks the currents passing through the components but may make errors in the other (highest to lowest) as $y > z > x$

	<p>3: Correct - Ranks the currents passing through the cell, R_1, and R_2 correctly from highest to lowest</p> <p>Criteria for 3: Student correctly ranks the currents passing through the components based on the principles of parallel circuits, where the current passing through each branch is inversely proportional to the resistance of that branch.</p> <p>$x > z > y$</p>
<p>4. Explain why similar bulbs connected in parallel to a cell produce the same brightness but dissimilar bulbs produce varying brightness.</p>	<p>1: Inaccurate - Provides an incorrect or unrelated explanation of the brightness comparison provides no response.</p> <p>Criteria for 1: Student presents an explanation that misinterprets or fails to address the factors influencing the brightness comparison, such as the voltage, and the resistance.</p> <p>2: Partially correct - Offers an explanation that is somewhat accurate but lacks clarity or completeness.</p>

	<p>Criteria for 2: Student mentions that similar bulbs the same properties, whereas the dissimilar ones have different properties since they are different.</p> <p>3: Correct - Provides a clear and accurate explanation of why similar bulbs produce the same brightness and dissimilar bulbs produce varying brightness.</p> <p>Criteria for 3: Student accurately explains that similar bulbs connected in parallel to a cell produce the same brightness because each bulb receives the same voltage from the power source. In parallel circuits, the potential difference across each branch (or bulb) is equal to the potential difference of the power source. Therefore, similar bulbs with the same voltage across them will emit the same brightness.</p> <p>Conversely, dissimilar bulbs have different resistances, causing them to draw different currents from the</p>
--	---

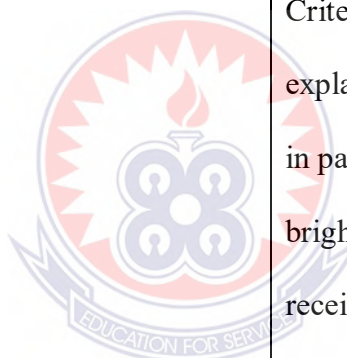

	<p>power source. Since the brightness of a bulb is directly proportional to the current passing through it (as per Ohm's law), bulbs with higher resistance draw less current and appear dimmer, while bulbs with lower resistance draw more current and appear brighter. Therefore, dissimilar bulbs produce varying brightness due to differences in their resistances, which affect the current flowing through them.</p>
--	--

