

**UNIVERSITY OF EDUCATION WINNEBA**  
**COLLEGE OF TECHNOLOGY EDUCATION KUMASI**

**COMPARATIVE ANALYSIS OF THE PERFORMANCE EVALUATION OF**  
**SOLAR BOX COOKER AND CONVENTIONAL METHOD**



**FRANCIS DERY**

**2021**

**UNIVERSITY OF EDUCATION WINNEBA**  
**COLLEGE OF TECHNOLOGY EDUCATION KUMASI**

**COMPARATIVE ANALYSIS OF THE PERFORMANCE EVALUATION OF**  
**SOLAR BOX COOKER AND CONVENTIONAL METHOD**



**A Thesis in the Department of MECHANICAL AND AUTOMOTIVE**  
**TECHNOLOGY EDUCATION, Faculty of Technical Education, Submitted to**  
**the School of Graduate Studies, University of Education Winneba, in partial**  
**fulfilment of the requirements for the award of Master of Philosophy**  
**(Mechanical Engineering Technology) degree**

**JUNE 2021**

## DECLARATION

### STUDENT'S DECLARATION

I, Dery Francis, hereby declare that this thesis, with the exception of quotations and references contained in published works which have all been identified and duly acknowledged, is entirely my own original work, and it has not been submitted, either in part or whole, for another degree elsewhere.

SIGNATURE: .....

DATE: .....



### SUPERVISOR'S DECLARATION

I hereby declare that the preparation and presentation of this work was supervised in accordance with the guidelines for supervision of Thesis as laid down by the University of Education Winneba.

SIGNATURE: .....

DATE: .....

**ENGR. C. K NWORU**

## ACKNOWLEDGEMENT

I thank Almighty God for the grace and mercy that has brought me this far, in starting and successfully completing this MPhil Mechanical Engineering programme. I will forever be grateful to him. I owe a special debt of gratitude to my supervisor, Mr. C.K Nworu for his patience, commitment, guidance, encouragement, support and critical way of supervision, which contributed to the successful completion of this work. Also, to all my lecturers in Department of MPhil Mechanical Engineering who facilitated various courses especially the Head of Department, Dr. Duodu I say profound thanks. I wish to express my deepest gratitude to my family, personalities, friends and course mates who offered me wonderful assistance in diverse ways throughout my education.

Finally, I want to express my deep heart thanksgiving and appreciation to my dear Parents Mr. Gbeder Methadius and Mrs. Maakapier Rose for their kind love, inspiration and guidance throughout my entire educational career.

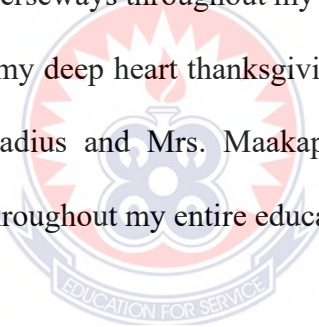

## **DEDICATION**

I dedicate this thesis work to my dear Wife Alice Tierukuu and lovely Children Peter Dery, Jeffrey Dery, and Jessica Dery for their prayers, support and encouragement which saw me through this journey.



## ABSTRACT

There is urgent need of switching over to a perennial source of energy reserve as a powerful alternative so as to replace all the fastest depleting fossil fuels. The solar box cooker depends on the sun energy whereas gas burner and coal pot depend on gas and charcoal as fuel. The purpose of the study is to design, construct and evaluate the performance of solar box cooker using locally available materials. Moreover, this study aimed to compare the constructed solar box cooker with charcoal and gas in terms of cooking time and energy cost. The constructed solar cooker relatively showed better performance in cooking different food for a large family. The dimension for the sides of the box used was 600mm x 500mm x 590mm representing the top two corners and height of the box. Also, the end part of the box before the base has outer and inner dimensions namely: 500mm and 470mm respectively while the dimension of the absorber plate which was divided into three parts namely; Top, middle, and base because the box is not having equal dimensions. The Top dimension was 500mm x 440mm. The middle has 445mm x 410mm and the base has 410mm x 410mm. Efficiency was noted to have increased with decreasing temperature differences between absorber plate and ambient (air) temperature ( $T_C - T_a$ ). Increase in temperature does not necessarily lead to increase in efficiency. Efficiency decreased with decreasing sunlight. The Solar Box Cooker (SBC) after being constructed and tested has 98.6% efficiency and its energy required to cook food was realized to be 410.849KJ. The energy required for charcoal and gas to cook food ranges from 1.664KJ, 1.536KJ, 1.6KJ and 906.048KJ, 878.592KJ, 878.592KJ respectively were recorded under the various weather conditions. This implies that gas burns faster than charcoal. It is therefore recommended that Solar Box Cooker should be used to combined with modified charcoal stove to cook food.

## TABLE OF CONTENTS

DECLARATION .....	ii
ACKNOWLEDGEMENT .....	iii
DEDICATION .....	iv
ABSTRACT.....	v
TABLE OF CONTENTS.....	vi
LIST OF TABLES.....	xi
LIST OF FIGURES .....	xii
CHAPTER ONE .....	1
INTRODUCTION .....	1
1.1 BACKGROUND TO THE STUDY.....	1
1.2 STATEMENT OF THE PROBLEM.....	4
1.3 PURPOSE OF THE STUDY.....	6
1.4 OBJECTIVES OF THE STUDY.....	7
1.5 SIGNIFICANCE OF THE STUDY.....	7
1.6 DELIMITATION.....	8
1.7 LIMITATION.....	8
1.8 ORGANIZATION OF THE STUDY .....	8
CHAPTER TWO .....	10
LITERATURE REVIEW .....	10
2.0 INTRODUCTION .....	10
2.1 THE CONCEPT OF SOLAR COOKER.....	10
2.2 THE DESIGN THEORY OF SOLAR COOKER .....	11
2.3 THE HISTORY OF THE PRINCIPLES AND OPERATIONS OF SOLAR COOKER.....	12

2.3.1 Working principles of solar cooker.....	12
2.3.2 Operation of Solar Cookers .....	13
2.3.3 Panel Solar Cooker .....	15
2.3.4 Parabolic Reflectors .....	17
2.3.5 Parabolic Troughs .....	21
2.3.6 Spherical Reflector.....	22
2.3.7 Vacuum Tube Technology.....	22
2.4 SOLAR COOKING TECHNOLOGIES.....	24
2.4.1 Reason for Placing Solar Cooker on Top of a Building .....	25
2.4.2 The Reason Why Solar Cooker Should Be Use Instead of Conventional Cooking Method .....	26
2.5 ECONOMIC ANALYSIS OF USING LOCAL SOLAR COOKER .....	26
2.5.1 The Production of Energy from Solar Cooker (Energy Produced by Solar Cooker) .....	27
2.5.2 The Content of Energy in LPG Cylinder (Energy Content of An LPG Cylinder) .....	27
2.5.3 Energy Content of a Fuel Wood .....	28
CHAPTER THREE .....	29
MATERIALS AND METHODS .....	29
3.0 INTRODUCTION .....	29
3.1 RESEARCH DESIGN .....	29
3.2 MATERIALS USED FOR THE DESIGN .....	29
3.2.1 Absorber Plate Design .....	29
3.2.2 Plywood .....	30
3.2.3 The Transparent Glass Plate .....	31



3.2.4 Cooking Glass Lid .....	32
3.2.5 The Reflector Mirror Design/Connection .....	32
3.2.6 Insulators .....	32
3.2.7 Thermometer/Thermocouples .....	32
3.3 DESIGN EQUATIONS .....	33
3.3.1 Analysis of Efficiency of The Solar Box Cooker .....	33
3.3.2 Efficiency of No-Loading (Stagnation) Temperature Test (Expt.1).....	33
3.3.3 The Percentage Efficiency at Loading Stage .....	34
3.3.4 Computation of Energy from Collector Plate .....	35
3.3.5 Computation of Energy from Charcoal on Bright Days .....	36
3.3.6 Computation of Energy from Gas on Bright Days .....	36
3.3.7 Computation of Energy from Charcoal on Low Cloudy Days .....	37
3.3.8 Computation of Energy from Gas on Low Cloudy Days .....	37
3.3.9 Computation of Energy from Charcoal on High Cloudy Days.....	37
3.3.10 Computation of Energy from Gas on High Cloudy Days.....	38
3.4 METHODS OF HEAT TRANSFER .....	38
3.4.1 Radiation .....	38
3.4.2 Conduction .....	39
3.4.3 Principle of Operation of Solar Cooker .....	39
3.5 DESIGN OF SOLAR BOX COOKER.....	40
3.5 DESIGN AND OPERATION .....	53
3.6.1 Box Space: .....	53
3.6.2 Solar Collection Area to Box Volume Ratio: .....	54
3.6.3 Solar Box Cooker Proportion: .....	54
3.6.4 Solar Box Cooker Operation.....	55

CHAPTER FOUR.....	56
RESULTS AND DISCUSSION .....	56
4.0 INTRODUCTION .....	56
4.1 SOLAR COOKER PROFILING .....	56
4.2 NO-LOADING TEMPERATURE TEST (WITHOUT CONCENTRATOR).....	57
4.2.1 Bright Day.....	57
4.2.2 Low Cloudy Days .....	59
4.2.3 Highly Cloudy Day .....	60
4.3 LOADING TEMPERATURE TEST (WITH CONCENTRATOR) .....	61
4.3.1 Bright Day/Sun Light.....	61
4.3.2 Low Cloudy Day .....	63
4.3.3 Highly Cloudy Day .....	64
4.4 LOADING TEMPERATURE TEST FOR CHARCOAL AND GAS .....	65
4.4.1 Temperature Testing for Gas and Charcoal for Bright Day .....	65
4.4.2 Temperature Testing for Gas and Charcoal in Low Cloudy Day .....	67
4.4.3 Temperature Testing for Gas and Charcoal in High Cloudy Day .....	68
4.5 NO-LOADING (STAGNATION).....	69
4.6 LOADING TEMPERATURE TEST.....	70
4.7 ANALYSIS OF EFFICIENCY OF THE SOLAR BOX COOKER.....	71
4.8 ANALYSIS OF HEAT ENERGY REQUIRED FOR CHARCOAL/GAS.....	73
4.9 COMPARISONS BETWEEN SOLAR/SUNLIGHT AND CHARCOAL OR GAS .....	73
CHAPTER FIVE.....	75
SUMMARY OF FINDINGS, CONCLUSIONS ANDRECOMMENDATIONS.....	75
5.1 INTRODUCTION: .....	75

5.2 SUMMARY OF FINDINGS .....	75
5.3 CONCLUSION.....	76
5.4 RECOMMENDATIONS.....	77
5.5 SUGGESTION FOR FURTHER STUDIES .....	78
REFERENCES .....	79
APPENDICES .....	85



## LIST OF TABLES

Table 4. 1: Bright Day/Sun Light .....	85
Table 4. 2: Low Cloudy Day.....	86
Table 4. 3: Highly Cloudy Day.....	87
Table 4. 4: Bright Day/Sun Light .....	88
Table 4. 5: Low Cloudy Day.....	89
Table 4. 6: Highly Cloudy Day.....	90
Table 4. 7: Temperature Testing for Gas and Charcoal.....	91
Table 4. 8: Temperature Testing for Gas and Charcoal in Low Cloudy Day .....	92
Table 4. 9: Temperature Testing for Gas and Charcoal in High Cloudy Day .....	93



## LIST OF FIGURES

Figure 2. 1: Hot dogs being cooked with a solar funnel cooker .....	11
Figure 2. 2: Solar oven in use .....	15
Figure 2. 3: Hot Pot panel solar cooker .....	16
Figure 2. 4: A Solar Oven made of cardboard, newspapers, and reflective tape.....	16
Figure 2. 5: Solar tea kettle in Tibet .....	17
Figure 2. 6: A parabolic solar cooker with segmented construction (Solar cooking Atlas official website).....	18
Figure 2. 7: A Scheffler cooker. This reflector has an area of 16 m <sup>2</sup> (170 sq ft), and concentrates 3 kW of heat.....	19
Figure 2. 8: An oblique projection of a focus-balanced parabolic reflector .....	20
Figure 2. 9: The Solar Bowl in Auroville .....	22
Figure 3. 1: Solar Box Cooker.....	40
Figure 3. 2: Exploded View of the SBC.....	41
Figure 3. 3: Detailed Drawing of SBC.....	42
Figure 3. 4: Side views, Stands and Footings of the SBC .....	43
Figure 3. 5: The Four (4) Side Walls of the Box and it's base .....	44
Figure 3. 6: Reflectors, Glass Cover, Wooden frame for reflectors, and Rolling stands .....	45
Figure 3. 7: Side View of a Solar Box Cooker .....	46
Figure 3. 8: Inside View of Solar Box Cooker Without Concentrator .....	47
Figure 3. 9: (a) Solar Box Cooker for Temperature Profiling with Concentrator .....	48
Figure 3. 10: Concentrator – Inside Top View .....	49
Figure 3. 11 Concentrator – Blackened Back View .....	49
Figure 3. 12: Solar Box Cooker for Temperature Profiling with Concentrator and	

Glass cover sliding open .....	50
Figure 3. 13: Coal Pot/Charcoal Stove for Temperature Profiling with Cooking Pot.	51
Figure 3. 14: Gas Stove for Temperature Profiling with Cooking Pot .....	52
Figure 4. 1: Solar Box Cooker Without Metallic Concentrator on a Bright Day (Max 68°C) .....	57
Figure 4. 2: Solar Box Cooker Without Metallic Concentrator on a Low Cloudy Day (Max 66°C).....	59
Figure 4. 3: Solar Box Cooker Without Metallic Concentrator on a Highly Cloudy Day (Max 54°C).....	60
Figure 4. 4: Solar Box Cooker with Metallic Concentrator on a Bright Day (Max 72°C) .....	62
Figure 4. 5: Solar Box Cooker with Metallic Concentrator on a Low Cloudy Day (Max 70°C).....	63
Figure 4. 6: Solar Box Cooker with Metallic Concentrator on a Highly Cloudy Day (Max 56°C).....	64
Figure 4. 7: Comparison for Gas (Max 90°C) and Charcoal (Max 74°C) .....	66
Figure 4. 8: Comparison for Gas (Max 86°C) and Charcoal (Max 62°C) .....	67
Figure 4. 9: Comparison for Gas (Max 86°C) and Charcoal (Max 62°C) in High Cloudy Days.....	68

## CHAPTER ONE

### INTRODUCTION

#### 1.1 BACKGROUND TO THE STUDY

Designing of solar cooker presents a viable alternative to the use of fuel wood, kerosene, and other fuels traditionally used in Ghana. A solar cooker is a simple, zero emission device that cook food and boils water using only the light of the sun. It turns sunlight directly into heat for cooking unlike photovoltaic cells, which convert sunlight into electricity. The use of solar energy technologies has increased considerably during the last decade. It is a large amount of solar energy that can be utilized throughout the year (Chaudhary, 2009). Many countries around the globe use solar cookers. Its usage increases as the prices of cooking fuel such as LPG, electricity, coal and kerosene increase. The importance of solar cooking is due to the high share of solar energy in world energy consumption (Park, Pandey, Tyagi, & Tyagi, 2014). Solar cooking has a large potential in the most populated countries, which have daily solar radiations of 5-7 kWh/m<sup>2</sup> and have a large number of sunny days per year (Mussard, Gueno & Nydal, 2013).

Designing and usage of solar cooker reduces the over dependent on burning of wood or coal and electricity as their source of energy for cooking. According to World Bank statistics, 94 % of the African rural population and 73 % of the urban population use fuel wood as their primary energy source (Melanic, 2006). Unfortunately supplies of fuel wood are diminishing throughout the world. As the cost and collection time for fuel wood increases, people seek for alternative sources (Garg, 1994). Studies have also shown that approximately 2.4 billion people depend on wood, dung, charcoal and other biomass fuels for cooking (Smith, Mehta & Maeusezahl-Feuz, 2004; Ruiz-

Mercado, Canuz, Walker & Smith, 2013). Most of these people cook on open fires, which burn incompletely thus leading to low fuel efficiency and high pollution emissions. Two to three million people die worldwide annually from cooking with traditional cook stoves and fuels, which mainly consist of fire wood and charcoal; most of these victims are women and children (Ruiz-Mercado, Canuz, Walker & Smith, 2013).

The World Health Organization suggests that indoor air pollution (IAP) resulting from burning solid fuels indoors in poorly ventilated conditions is responsible for 3.3% of the global Burden on disease (World Health Organisation.,2009). The current patterns of energy use cause significant negative impact of several types, including human morbidity and mortality, outdoor air pollution, climate change and deforestation (Ruiz-Mercado, et al, 2013). In many sunny parts of the world, solar cooking is a viable option (Nandwani,1992, Devadas, 1992, 1997, Olusegun, 2006). The need to cook food for nourishment is fundamental to every society and this requires the use of energy in some form. The use of solar energy to meet this important need apart from being a viable alternative is also accomplished without the environmental and health problem associated with most other fuels (Shaw, 2003).

In Ghana, the technology of solar cooking started 2002 when a project headed by Dr. Mercy Bannerman emerged as one of the top winners at the World Bank's Development Marketplace, an occasion that takes place yearly to display excellent innovations in less developed nations (Mae & Matlock, 2013). There are now many designs and types, most of which fall within: the concentrator type, box type, panel type cookers and a combination of the aforementioned designs. Solar cookers are typically designed to achieve temperature  $65^{\circ}$  to  $400^{\circ}$  on a sunny day. Solar cookers concentrate sunlight on cooking pan (Ronge, Niture, & Ghodake, 2016). Interaction



between receiver material and sunlight converts sunlight into heat energy. Pots and pan used for cooking must be in black color only. It is most important to insulate the cooker simply by using glass lid on pot. It minimizes convection loss of heat energy in the solar cooker (Ronge et al., 2016).

Many efforts have taken place over the years (Wary, 1992, Warren, 1994). Different solar cookers have been tested by researchers at specific geographical locations and under unique climate and physical conditions (Malik et al, 1996, Adegoke, et al, 1998). One of the most common solar cooker types is the box solar cooker in different versions (Daniel, 1990, Amer, 2003, Ekechukwu et al, 2003, Negi et al, 2005). Another solar cooker type is the concentration type where the solar radiation is directed to convey at a point called the focal point where the cooking pot is placed (Kulkarni et al, 1997; Patel et al, 2000; Hussein et al, 2008). It is as a result of this the research was carried out by designing and constructing solar cooker using locally available material in Ghana.



## 1.2 STATEMENT OF THE PROBLEM

In early times, energy is completely harnessed from fossil fuels (LPG, oil and coal). As human beings become more civilized, their industries also grow, which in turn increased energy demand. The regular increase in population contributed to the increase in energy demand (Shahbaz et al,2017;Okino et al, 2021;Katiyar et al,2013). This caused an increase in the demand of fossil fuels.

Global warming, which is caused by the increase in the concentration of green house gases in the atmosphere due to the burning of fossil fuels, causes the increase of the earth's mean temperature (Makenzi et al,2020).This in turn causes climate change, which is responsible for different hazards such as flood and drought (Fahad et al, 2018).The burning of fossil fuels also causes acid rain, which can caused an adverse impact on forest, soil and water bodies (Ramanahan et al,2020).

More than 2.2 million Ghanaian families in rural areas depend on firewood and charcoal as fuel for cooking (Kwakwa, Paul & Wiafe, Edward & Alhassan, Hamdiyah. 2013). This high dependency is taking a toll on forest resources due to rampant deforestation. "Ghana's forest cover, which stood at 8.2 million hectares in 1900, has now been reduced to about 1.2 million hectares, with an estimated loss of 65,000 hectares of forest annually" (Acheampong,E .2010).

The rise in the population size of Ghana makes the exploitation of fuelwood, charcoal, and gas more alarming. With the high dependency on wood as fuels and the increase in demand for them, the effect is an increase in deforestation and hence a disruption in the country's ecosystem (Ghana Investment Plan, Ministry of Lands and Natural Resources, 2012). More so, the use of charcoal and firewood pose health risks to girls and women due to the exposure to heat and smoke.

According to Hafner and Tagliapietra,(2020) after a few hundred years, all fossil fuels in Sub-Sahara African countries will be extracted.

Solar cooking can be used as an effective mitigation tool with regards to global climate change, deforestation, and economic debasement of the world's poorest people. Over one-third of the population of the world depends on firewood daily as the source of cooking and heating energy.

Majority live in the tropics where Ghana also belongs and which also serves as most favorable areas for use of solar energy. Every year the cutting of firewood results in the loss of 20,000 -25,000 km<sup>2</sup> of tropical forests (UNEP, 2013). These figures are staggering in their implications and are at least partially, reducible using solar cooking technology (Addison & Keith, 2013).

With the growing problem of deforestation in Ghana, solar cookers can make a big difference. Families in the developing like Ghana will spend 20 – 30% of their income on fuel for cooking, yet in many places there is a much cheaper way of cooking – using the sun (Ismail & Isa, 2013). Conventional traditional methods of cooking pose a lot of hazards such as the alarming rate of climate change, increased number of deaths and health hazards and deforestation. One adverse effect arising from the use of these traditional cook stoves is the generation of soot which poses human and environmental hazards. To solve the above problems in addition to energy conservation, researchers started to study more about the possible alternative energy resources such as solar, tidal, biomass, wind, hydro and geothermal, which are popularly known as renewable energy (Abbas et al,2020; Thirugnanam et al,2020 ; Nayak et al,2016; Calabro E,2013). The researcher came up with this idea because of a strong desire to solve the needs of the communities in remote rural areas of Ghana that experience shortage of energy resources. The households in many rural areas in

Ghana use other energy resources mainly for cooking and heating.

Local households in rural areas burn wood or coal as an aftermath of severe shortage of natural gas. Such resources are expensive and not always accessible. Moreover, the use of such resources is harming the environment and human health. The designing and construction of solar cooker will be an alternative and sustainable source of energy for cooking especially for low-income families. The families can do a one-time investment and use this product for many years. Low cost solar cookers are very efficient and an environmentally friendly alternative solution to the energy problem in rural areas of Ghana. Renewable energy plays an important role to have affordable, reliable and easy accessible energy for all (Hulio et al,2021). A search through literature revealed that many women and girls depends on firewood, charcoal and gas for cooking, hence they are at risk to several health hazards and also causing deforestation which is gradually leading to desertification especially in the Northern part of Ghana. It is as a result of this the research will be carried out by designing, constructing and evaluating the performance of solar box cooker with four reflectors compare with conventional traditional methods of cooking food.

### **1.3 PURPOSE OF THE STUDY**

The purpose of the study is to design and construct solar box cooker using local materials in Ghana to minimize the human impact on the environment. Also, compare the use of Solar Box Cooker (SBC) with that of charcoal and gas in our domestic homes.

#### **1.4 OBJECTIVES OF THE STUDY**

The specific objectives of the study were:

1. To redesign and construct solar cooker using local raw materials.
2. To test and analyze the performance of constructed solar cooker using local materials.

#### **1.5 SIGNIFICANCE OF THE STUDY**

Solar cooking has been in existence for a very long time. Different models of the solar cookers have been manufactured over the years. Various innovative test standards have been evaluated and tested. It is expected that the society will benefit from the designing and construction of solar cooker, the entire society will benefit from using solar panels instead of relying on traditional natural gas and electricity, which is very scarce in many parts of the country. The usage of this solar cooker by households will also reduce the negative impact on the environment and human health.

The benefit of using the local materials and recycled materials in production of solar cooker will minimize the human impact on the environment and at the same time to generate renewable energy from the sun. Also, the design of cost-effective solar cooker will encourage easier adoption of solar cooker technology due to the user benefits.

The cooker will cater for substantial household cooking energy needs hence reduce on carbon emissions in the atmosphere. Implementation of the design will reduce on the time spent by women and girls collecting firewood since traditionally they are the ones that carry out such activities in Ghana. Certainly, the adoption of the solar cooker will enable cost savings compared to alternative biomass sources of fuel. The study will also add to the existing body of knowledge of manufacturing solar cooker and identify area of research gaps that need further research attention.

## **1.6 DELIMITATION**

The study was carried out in Ghana. The raw materials for the design were sourced locally; these include Aluminum metal sheet, Glue, Glass plate and  $\frac{3}{4}$  Plywood. The designed solar box cooker has four reflectors sides which has the advantage of concentrating more sunlight radiation into the inner cooking pot. The heat storage boxes were constructed with plywood and Aluminum sheet painted black in the inside and rectangular in shape.

## **1.7 LIMITATION**

The major issues that caused the researcher to delayed the construction of the Solar Box Cooker was based on the availability of money to buy the items needed for the construction. Also, the availability of the instruments (100<sup>0</sup>C Mercury/digital thermometer) used to measure the temperature was an issue. There were no extra sensors or mercury thermometers to use as the experiments were being performed simultaneously. The manual way of tracking the infra-red radiation was performed simultaneously but it was quite tedious. The Solar Box Cooker was experienced loss of heat energy as they had to be opened up for its temperature to be read.

## **1.8 ORGANIZATION OF THE STUDY**

The study is organized into five major chapters and specific issues are discussed in each of the chapters. The chapters include Introduction, Literature Review, Materials and methods, Results and Discussion, Summary of findings, Conclusions and Recommendations. The summary of each chapter is provided as follows:

Introduction: The highlights of the chapter are the background of the Study, statement of the problem, Purpose of the study, objective of the study, significant of the study,

delimitation of the study, Limitation and organization of the study; Literature Review: The researcher reviews the available literature on the redesigning and construction of solar box cooker, performance of constructed solar cooker using local materials, and economic analysis of using local solar cooker compared with other sources of solar cooker. The review also covers the conceptual framework of the study; materials and methods. The chapter covers the discussion of all the research methods and techniques. The highlights of the chapter are research design, the design theory, materials for redesigning and construction, and the data analysis procedure. Results and Discussions: The data obtained through the redesigning and construction of solar box cooker are presented in this chapter. The presentation was captured in figures and tables. The results of the study were discussed in this chapter. Summary of findings, Conclusions, Recommendations, and Suggestions for further studies: This is the last chapter of the study and it records the summary, the conclusions made based on the presentations, analysis and the recommendations.

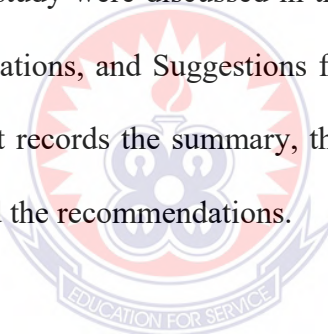

## CHAPTER TWO

### LITERATURE REVIEW

#### 2.0 INTRODUCTION

The section reviews the relevant literature that have strong relations to the research topic. It reviews theoretical literature as well as contemporary empirical literature.

#### 2.1 THE CONCEPT OF SOLAR COOKER

A solar cooker is a hollow chamber with its base closed and its upper part opened which serves as the medium for radiant energy from the sun passes via a transparent glazing cover into the inner part of the box to be retained. The glass cover converting the beam of rays into heat energy. The radiant energy from the sun does not need any material medium for its propagation (Dery F, 2020).

There are many types of solar cookers with or without reflectors that are available in the job market for public use namely; the concentrator, box, panel and the combination of any of these solar cookers. Some are very unusual because they are expensive.

The recent form of solar cookers is now cheap and easy to be used, because they use no petrol (fuel) and cost nothing to operate. Most zero profit organizations or institutions are enhancing their use across the whole world so that it can assist to decrease fuel cost, reduced air pollution, deforestation hence reduced climate change and desertification which comes as a result of cutting down of trees for fire wood for domestic purposes. Furthermore, the concept of solar cookers from the perspective of other point of views of researchers is as given below:

Many solar cookers currently in use are relatively inexpensive, low-tech devices, although some are as powerful or as expensive as traditional stoves (Cantina, 2014) and advanced, large-scale solar cookers can cook for hundreds of people (Inhabitat, 2014).



Because they use no fuel and cost nothing to operate, many non-profit organizations are promoting their use worldwide in order to help reduce fuel costs (especially where monetary reciprocity is low) and air pollution, and to slow down the deforestation and desertification caused by gathering firewood for cooking.



**Figure 2. 1: Hot dogs being cooked with a solar funnel cooker**

## **2.2 THE DESIGN THEORY OF SOLAR COOKER**

The review of the design theory of the solar cooker in this study constitute an experimental procedure, the computation of the values which was classify under 1<sup>st</sup> and 2<sup>nd</sup> figures of merits and the efficiencies of the cooking process of our domestic meals using a solar box cooker. In the experiment, various sequence of data systems is recorded. The temperatures of No-load and Full load test in various types of substances such as water, food, boiling rate, energy required to cook the food is calculated the measure temperatures is carry out simultaneously. The temperature evolution is defined using Mercury in glass thermometer or thermocouples find inside the box. After taken the measurement of the evolution temperatures in a solar cooker thermodynamics' principle are apply to determine the first and second laws of efficiencies. The outcomes obtain shows what is the numerical difference between the first and second laws in the cooking sequence of needs. The outcomes made us

understand how the inlet energy that impact on solar cooker is converted in energy usefulness in the cooking process of domestic meals. This piece of research work is to use for future design of solar box cookers.

## **2.3 THE HISTORY OF THE PRINCIPLES AND OPERATIONS OF SOLAR COOKER**

The first academic description of the principles of a solar cooker is by the Swiss geologist, meteorologist, physicist, mountaineer and Alpine explorer Horace-Bénédict de Saussure, in 1767. The principle of cooking meals from the sun was largely developed in the French Foreign Legion, in the 1870s ([solarcooking.org](http://solarcooking.org)).

### **2.3.1 Working principles of solar cooker**

A surface mirror with high specular reflection is used to concentrate radiant energy from the sun into a small cooking point. Depending on the geometry of the surface, radiant energy could be concentrated by several orders of magnitude producing temperatures high enough to melt solid substances (salt). For most domestic solar cooking applications, large temperatures are not really needed. Solar cooking products are typically designed to achieve various forms of higher temperatures to cook different types of food. Radiant energy is converted into heat energy and concentrate it onto a cooking pot (collector). The interaction between the solar light energy and the receiver material converts light to heat and this is called conduction. This conversion is increased by using good conductor materials that produce and retain heat energy. Cooking vessels or utensils used on solar cookers should be painted black in color to increase the absorption rate of heat.

It is necessary to reduce convection by isolating the air inside the solar cooker from

the air outside the cooker. Simply using a glass lid on your cooking vessels enhances light absorption from the top of the pan and provides a greenhouse effect that improves heat retention and reduces heat loss by convection. This "glazing" transmits incoming visible sunlight but is opaque to escaping infrared thermal radiation. Due to lack of available materials, a high temperature plastic container can serve a similar function, trapping air inside and making it possible to reach temperatures on more windy and cold weather condition periods similar to those possible on high sunny days.

The below shows the demonstration of fundamental science for solar panel cookers and solar box cookers. Another style of solar cooker is a parabolic solar cooker. They typically require more regular reorientation to the sun, but will cook faster at maximum temperatures, and can fry meals. Evacuated tube solar cookers use a highly insulated double-wall glass tube for the cooking chamber, hence do need small reflectors.

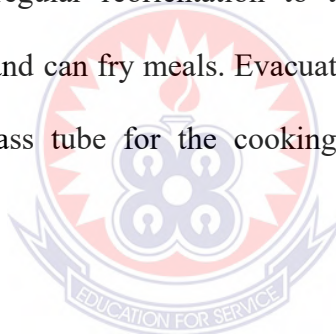

### **2.3.2 Operation of Solar Cookers**

Different kinds of solar cookers (more than 300 models of solar cooker had been made so far) use somewhat different methods of cooking, but most follow the same basic principles. Food is prepared as if for an oven or stove top. However, because food cooks faster when it is in smaller pieces, food placed inside a solar cooker is usually cut into smaller pieces than it might otherwise be (Yaffe, Linda Frederick, 2007). For example, potatoes are usually cut into bite-sized pieces rather than roasted whole (Halacy, D. S; Halacy, Beth, 1992). For very simple cooking, such as melting butter or cheese, a lid may not be needed and the food may be placed on an uncovered tray or in a bowl. If several foods are to be cooked separately, then they are

placed in different containers.

The container of food is placed inside the solar cooker, which may be elevated on a brick, rock, metal trivet, or other heat sink, and the solar cooker is placed in direct sunlight (Yaffe, Linda Frederick, 2007). Foods that cook quickly may be added to the solar cooker later. Rice for a mid-day meal might be started early in the morning, with vegetables, cheese, or soup added to the solar cooker in the middle of the morning. Depending on the size of the solar cooker and the number and quantity of cooked foods, a family may use one or more solar cookers as shown in the figure 2.2 below.





**Figure 2. 2: Solar oven in use**

### **2.3.3 Panel Solar Cooker**

A box cooker has a transparent glass or plastic top, and it may have additional reflectors to concentrate sunlight into the box. The top can usually be removed to allow dark pots containing food to be placed inside. One or more reflectors of shiny metal or foil-lined material may be positioned to bounce extra light into the interior of the oven chamber. Cooking containers and the inside bottom of the cooker should be dark-colored or black. Inside walls should be reflective to reduce radioactive heat loss and bounce the light towards the pots and the dark bottom, which is in contact with the pots. The box should have insulated sides. Thermal insulation for the solar box cooker must be able to withstand temperatures up to 150°C (300 °F) without melting or out-gassing. Crumpled newspaper, wool, rags, dry grass, sheets of cardboard, etc. can be used to insulate the walls of the cooker.



**Figure 2. 3: Hot Pot panel solar cooker**

Metal pots and/or bottom trays can be darkened either with flat-black spray paint (one that is non-toxic when warmed), black tempera paint, or soot from a fire. The solar box cooker typically reaches a temperature of 150 °C (300 °F). This is not as hot as a standard oven, but still hot enough to cook food over a somewhat longer period of time as shown in figure 2.4 below.



**Figure 2. 4: A Solar Oven made of cardboard, newspapers, and reflective tape**

Panel solar cookers are inexpensive solar cookers that use reflective panels to direct sunlight to a cooking pot that is enclosed in a clear plastic bag. Solar Oven science experiments are regularly done as projects in high schools and colleges, such as the "Solar Oven Throwdown" at the University of Arizona (UANEWS, 2013) These projects prove that it is possible to both achieve high temperatures, as well as predict the high temperatures using mathematical models.



### 2.3.4 Parabolic Reflectors

Parabolic solar cookers concentrate sunlight to a single point. When this point is focused on the bottom of a pot, it can heat the pot quickly to very high temperatures which can often be comparable with the temperatures achieved in gas and charcoal grills. These types of solar cookers are widely used in several regions of the world, most notably in China and India where hundreds of thousands of families currently use parabolic solar cookers for preparing food and heating water. Some parabolic solar cooker projects in China abate between 1–4 tons of carbon dioxide per year and receive carbon credits through the Clean Development Mechanism (CDM) and Gold Standard.



**Figure 2. 5: Solar tea kettle in Tibet**

Some parabolic solar cookers incorporate cutting edge materials and designs which lead to solar energy efficiencies greater than 90%. Others are large enough to feed thousands of people each day, such as the solar bowl at Auroville in India, which makes 2 meals per day for 1,000 people (Archive.org, 2014).

If a reflector is axially symmetrical and shaped so its cross-section is a parabola, it has the property of bringing parallel rays of light (such as sunlight) to a point focus. If the axis of symmetry is aimed at the sun, any object that is located at the focus receives

highly concentrated sunlight, and therefore becomes very hot. This is the basis for the use of this kind of reflector for solar cooking.



**Figure 2. 6: A parabolic solar cooker with segmented construction (Solar cooking Atlas official website).**

Paraboloids are compound curves, which are more difficult to make with simple equipment. Although paraboloidal solar cookers can cook as well as or better than a conventional stove, they are difficult to construct by hand. Frequently, these reflectors are made using many small segments that are all single curves which together approximate compound curves. Although paraboloids are difficult to make from flat sheets of solid material, they can be made quite simply by rotating open-topped containers which hold liquids. The top surface of a liquid which is being rotated at constant speed around a vertical axis naturally takes the form of a paraboloid. Centrifugal force causes material to move outward from the axis of rotation until a deep enough depression is formed in the surface for the force to be balanced by the levelling effect of gravity. It turns out that the depression is an exact paraboloid. As shown in figure 2.6. If the material solidifies while it is rotating, the paraboloidal shape is maintained after the rotation stops, and can be used to make a reflector. This rotation technique is sometimes used to make paraboloidal mirrors for astronomical telescopes, and has also been used for solar cookers. Devices for constructing such



paraboloids are known as rotating furnaces.

The figure 2.7 below is a clear example of Paraboloidal reflectors that produce more temperatures and cook faster, but require frequent adjustment and monitoring for safe operation. They are useful for individual household and large-scale institutional use.

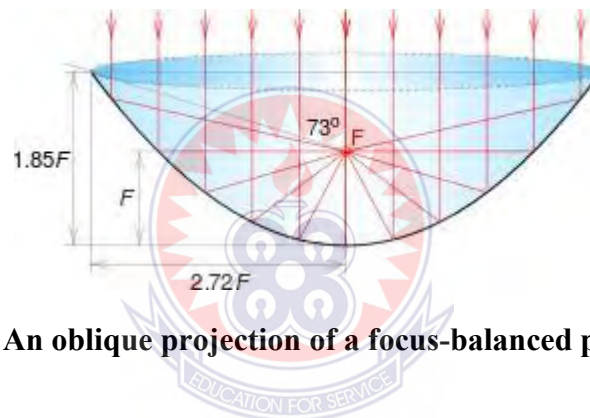

**Figure 2. 7: A Scheffler cooker. This reflector has an area of 16 m<sup>2</sup> (170 sq ft), and concentrates 3 kW of heat**

A Scheffler cooker (named after its inventor, Wolfgang Scheffler) uses a large ideally paraboloidal reflector which is rotated around an axis that is parallel with the earth's using a mechanical mechanism, turning at 15 degrees per hour to compensate for the earth's rotation. The axis passes through the reflector's Centre of mass, allowing the reflector to be turned easily. The cooking vessel is located at the focus which is on the axis of rotation, so the mirror concentrates sunlight onto it all day. The mirror has to be occasionally tilted about a perpendicular axis to compensate for the seasonal variation in the sun's declination. This perpendicular axis does not pass through the cooking vessel. Therefore, if the reflector were a rigid paraboloid, its focus would not remain stationary at the cooking vessel as the reflector tilts. To keep the focus stationary, the reflector's shape has to vary. It remains paraboloidal, but its focal length

and other parameters change as it tilts. The Scheffler reflector is therefore flexible, and can be bent to adjust its shape. It is often made up of a large number of small plane sections, such as glass mirrors, joined together by flexible plastic. A framework that supports the reflector includes a mechanism that can be used to tilt it and also bend it appropriately. The mirror is never exactly paraboloidal, but it is always close enough for cooking purposes (Sarker,2015).

Sometimes, the rotating reflector is located outdoors and the reflected sunlight passes through an opening in a wall into an indoor kitchen, often a large communal one, where the cooking is done.



**Figure 2. 8: An oblique projection of a focus-balanced parabolic reflector**

Paraboloidal reflectors that have their center of mass coincident with their focal points are useful. They can be easily turned to follow the sun's motions in the sky, rotating about any axis that passes through the focus. Two perpendicular axes can be used, intersecting at the focus, to allow the paraboloid to follow both the sun's daily motion and its seasonal one. The cooking pot stays stationary at the focus. If the paraboloidal reflector is axially symmetrical and is made of material of uniform thickness, its center of mass coincides with its focus if the depth of the reflector, measured along its axis of symmetry from the vertex to the plane of the rim, is 1.8478 times its focal length. The radius of the rim of the reflector is 2.7187 times the focal length. The angular radius of the rim, as seen from the focal point, is 72.68 degrees.

### 2.3.5 Parabolic Troughs

Parabolic troughs are used to concentrate sunlight for solar-energy purposes. Some solar cookers have been built that use them in the same way (Shah & Yatish T., 2018). Generally, the trough is aligned with its focal line horizontal and east-west. The food to be cooked is arranged along this line. The trough is pointed so its axis of symmetry aims at the sun at noon. This requires the trough to be tilted up and down as the seasons progress. At the equinoxes, no movement of the trough is needed during the day to track the sun (Prinsloo & Dobson RT., 2015). At other times of year, there is a period of several hours around noon each day when no tracking is needed. Usually, the cooker is used only during this period, so no automatic sun tracking is incorporated into it. This simplicity makes the design attractive, compared with using a paraboloid. Also, being a single curve, the trough reflector is simpler to construct. However, it suffers from lower efficiency.

It is possible to use two parabolic troughs, curved in perpendicular directions, to bring sunlight to a point focus as does a paraboloidal reflector. The incoming light strikes one of the troughs, which sends it toward a line focus. The second trough intercepts the converging light and focuses it to a point.

Compared with a single paraboloid, using two partial troughs has important advantages. Each trough is a single curve, which can be made simply by bending a flat sheet of metal. Also, the light that reaches the targeted cooking pot is directed approximately downward, which reduces the danger of damage to the eyes of anyone nearby. On the other hand, there are disadvantages. More mirror material is needed, increasing the cost, and the light is reflected by two surfaces instead of one, which inevitably increases the amount that is lost. The two troughs are held in a fixed orientation relative to each other by being both fixed to a frame. The whole assembly

of frame and troughs has to be moved to track the sun as it moves in the sky. Commercially made cookers that use this method are available. In practical applications (like in car-head lights), concave mirrors are of parabolic shape.

### 2.3.6 Spherical Reflector

Spherical reflectors operate much like paraboloidal reflectors, such that the axis of symmetry is pointed towards the sun so that light is concentrated to a focus. However, the focus of a spherical reflector will not be a point focus because it suffers from a phenomenon known as spherical aberration. Some concentrating dishes (such as satellite dishes) that do not require a precise focus opt for a spherical curvature over a paraboloid. If the radius of the rim of spherical reflector is small compared with the radius of curvature of its surface (the radius of the sphere of which the reflector is a part), the reflector approximates a paraboloidal one with focal length equal to half of the radius of curvature as shown in figure 2.9 below.



**Figure 2. 9: The Solar Bowl in Auroville**

### 2.3.7 Vacuum Tube Technology

Evacuated tube solar cookers are essentially a vacuum sealed between two layers of glass. The vacuum allows the tube to act both as a "super" greenhouse and an

insulator. The central cooking tube is made from borosilicate glass, which is resistant to thermal shock, and has a vacuum beneath the surface to insulate the interior. The inside of the tube is lined with copper, stainless steel, and aluminum nitride to better absorb and conduct heat from the sun's rays. Some vacuum tube solar cookers incorporate light weight designs which allow great portability such as the Go Sun stove (Fincher & Jonathan, 2013). Portable vacuum tube cookers such as the Go Sun allow users to cook freshly caught fish on the beach without needing to light a fire (Twmffat & Tecwyn, 2016).

The advantages of vacuum tube technology include:

- i. High-performance parabolic solar cookers and vacuum tube cookers can attain temperatures above 290°C (550°F). They can be used to grill meats, stir-fry vegetables, make soup, bake bread, and boil water in minutes. Vacuum tube type cookers can heat up even in the clouds and freezing cold.
- ii. Conventional solar box cookers attain temperatures up to 165°C (325°F). They can sterilize water or prepare most foods that can be made in a conventional oven or stove, including bread, vegetables and meat over a period of hours.
- iii. Solar cookers use no fuel. This saves cost as well as reducing environmental damage caused by fuel use. Since 2.5 billion people cook on open fires using biomass fuels, solar cookers could have large economic and environmental benefits by reducing deforestation (World Health Organisation, 2014).
- iv. When solar cookers are used outside, they do not contribute inside heat, potentially saving fuel costs for cooling as well. Any type of cooking may evaporate grease, oil, and other material into the air, hence there may be less clean up.
- v. Reduces your carbon foot print by cooking without the use of carbon-based fuels or grid electricity from traditional sources (The Tiny Life, 2018).

Also, the following are the disadvantages of vacuum tube technology:

- i. Solar cookers are less useful in cloudy weather and near the poles (where the sun is low in the sky or below the horizon), so an alternative cooking source is still required in these conditions. Solar cooking advocates suggest three devices for an integrated cooking solution: a) a solar cooker; b) a fuel-efficient cook stove; c) an insulated storage container such as a basket filled with straw to store heated food. Very hot food may continue to cook for hours in a well-insulated container. With this three-part solution, fuel use is minimized while still providing hot meals at any hour, reliably.
- ii. Some solar cookers, especially solar ovens, take longer to cook food than a conventional stove or oven. Using solar cookers may require food preparation start hours before the meal. However, it requires less hands-on time during the cooking, so this is often considered a reasonable trade-off.
- iii. Cooks may need to learn special cooking techniques to fry common foods, such as fried eggs or flat breads like chapatis and tortillas. It may not be possible to safely or completely cook some thick foods, such as large roasts, loaves of bread, or pots of soup, particularly in small panel cookers; the cook may need to divide these into smaller portions before cooking.
- iv. Some solar cooker designs are affected by strong winds, which can slow the cooking process, cool the food due to convective losses, and disturb the reflector. It may be necessary to anchor the reflector, such as with string and weighted objects like bricks.

## **2.4 SOLAR COOKING TECHNOLOGIES**

A technology used in solar cookers is one of the mitigation tools for using radiant

energy to cook food of which many people all over the world is aware of and being practiced. This reduced over dependent of the use of firewood and LPG to prepare food. Some families in Indian and other part of the country in Ghana experienced high intensity of sunlight and they have realized the benefits one can derive from the use of solar panel to provide electricity and some have developed interest in buying solar cookers because they have attended nations wide solar cooking program, this program is one of the many national and international solar cooking projects implemented in high sunny regions like Upper West Region of Ghana.

The solar box cooker is an insulated box for example with dimension 600mm × 500mm × 590mm with a glazed top window when put in the sun it cooks vegetables, yams, beans and meal within three hours. This cooker can cook enough food to feed a maximum number not more than six people in a family for one to use this technology effectively and efficiently to cook food they still use the conventional method to supplement the use of solar cooking since it is not every time within the year one can experience high intensity of sunlight.

#### **2.4.1 Reason for Placing Solar Cooker on Top of a Building**

The alternative way of placing solar box cooker on top of building comes as a result of lack of space to domestic houses where the place is congested.

Also, one needed to place solar box cooker on the upper part of a building to reduce the hazards of dust, damage caused by children, wandering animals and theft.

Another reason is that because of shades of trees that falls on verandas or surroundings, there will not be enough sunlight to help the solar cooker to cook food since the shadows of trees will serve as a means of interruption to the sunlight. So, a possible alternative place where many domestic homes can get access of enough



sunlight is the top of a building.

The top apartment of the building (roof) of a building is a suitable place if we only consider availability of sunlight. This is not applicable every home instead a story building with an open space is a preferable one where this can be practiced. It is important to note that, a solar box cooker with a lighter weight is suitable for the roof apartment of a cook to be easy to carry up and down the roof.

#### **2.4.2 The Reason Why Solar Cooker Should Be Use Instead of Conventional Cooking Method**

It is important to note that solar cooking is easier and more time-saving as compared to the conventional cooking method. The reason why it is easy and time-saving to use solar box cooking is that, the raw food when put in the box solar cooker it does not required that the cook should regularly pay attention to the cooking process, for the solar cooker function as a hot oven and the glass window cover of the solar cooker is supposed to be kept closed throughout the cooking period. This means that sun cooking takes place under high or low temperature within the solar cooker. It is necessary to evaluate how practical solar cooking process is, it thus becomes important to place it in a wider context. This means that low-temperature sun cooking occurs in several changes on cooking procedures, therefore, ease and time-saving are not the only changes but a part of a range of changes.

#### **2.5 ECONOMIC ANALYSIS OF USING LOCAL SOLAR COOKER**

The economic viability of any system is computed through the use of economic



analysis of the system. The outcome of any large quantity of new technology it is important for one to know either the technology is economically viable or not viable.

The solar cooker can be used as the alternative means of cooking food instead of using the traditional methods (conventional) of cooking fuels like LPG and fire-wood. To consider the economic analysis and its benefits, payback period was computed when solar cooking technology is replaced by the LPG cylinders and fire wood used for cooking food.

### **2.5.1 The Production of Energy from Solar Cooker (Energy Produced by Solar Cooker)**

The heat energy produced by the solar cooker per day can be calculated by using the following formula (Singh, 2009);

= Family members × No. of meals × percent of meal can cook × Heat required for cooking for single person (KJ).

### **2.5.2 The Content of Energy in LPG Cylinder (Energy Content of An LPG Cylinder)**

If an LPG cylinder were replaced by a solar cooker equivalent energy production can be calculated by using the following formula (Singh, 2009);

= Cylinder total useful energy / Energy produced by cooker per day.

The useful energy content of an LPG cylinder can be calculated by using the following formula (Singh, 2009);

Useful energy per cylinder = Total energy from cylinder x useful energy (0.6).

Payback period of solar cooker replaced by LPG cylinder

= cost of developed solar cooker (Rs)

cost of energy saved per year (Rs)

### 2.5.3 Energy Content of a Fuel Wood

Assuming when fuel wood replaces by solar cooker for cooking, payback period of solar cooker was calculated by using following formula (Garba, 2014);

$$\text{Payback period} = \frac{\text{cost of developed solar cooker (Rs)}}{\text{cost of energy saved per year}}$$



## **CHAPTER THREE**

### **MATERIALS AND METHODS**

#### **3.0 INTRODUCTION**

This chapter presents details of materials and methods used for the study. It discusses the research design, materials used and testing of the design and construction of solar cooker. The researcher provided the various pictures of the design of SBC compare with the conventional ways of preparing food. In addition, it deals with the economic analysis and carbon emissions reduction of the solar cooker. AutoCAD software was used for designed and modelled of the structure.

#### **3.1 RESEARCH DESIGN**

The researcher chose experimental design because it helps him employed a process of redesigning and constructing Solar Box Cooker using local materials, testing temperature using thermocouples or 100<sup>0</sup>C Mercury in glass thermometers and analyzing data using design equations.

#### **3.2 MATERIALS USED FOR THE DESIGN**

The design and construction of solar cooker was done by using local materials such as  $\frac{3}{4}$  inches (82.55mm) thick Plywood, 1mm Aluminum sheet (Aluzic), Glue (supper 99), white glue, insulators (foam), reflector mirror and glass lid.

##### **3.2.1 Absorber Plate Design**

Metal flat bar was used to flattening the corrugated surface when the sheet was placed on top of an Anvil. Roofing nail was used to mark out the edges before cutting using the roofing cutter. A plier was used to hold the meeting edges together to make them

firm before using the wooden mallet to close the edges. This was used to cut out the same shape of the 1 mm aluminum sheets, bent, Aluminum foil was rolled over the collector faces, cut to sizes and glued to improve the reflectivity of the collector surface. Small nails were used to hold the lower collector faces on the outer box to enable the reflected mirror to be hinged unto them to prevent wind effect on the mirrors.

### **3.2.2 Plywood**

The researcher deems it necessary using plywood since it is locally available and very easy, and cheap to get in Ghana. It is an opaque substance and does not allow light to pass through it. It contains a natural polymer based on the cellulose molecules. It has strength and stiffness parallel to the grain but is weak across the grain. It is a much weaker material in compression than in tension. The thickness of the wood used in constructing the sides and base of the box is  $\frac{3}{4}$  inches (82.55mm). These thicknesses are used so that the box will not be too heavy. Each side of the box is lagged using foam to prevent heat loss due to conduction from the absorber plate. When the wood is lagged, heat escaping from its sides is very small and the flow per second is now constant along the length of the wood.

The dimension for the sides of the box used was 600mm × 500mm × 590mm representing the top two (2) corners and height of the box. Also, the end part of the box before the base has outer and inner dimensions namely: 500mm and 470mm respectively while the dimension of the absorber plate which was divided into three parts namely; Top, middle, and base because the box is not having equal dimensions. The Top dimension was 500mm × 440mm. The middle has 445mm × 410mm and the base has 410mm × 410mm as shown in figure 3.3 below.

There are grooves around the top of the box to serve as a slot for the transparent glass mirrors that covers the box. The inner part of the box is painted black to absorb the heat and trap the heat needed for cooking. A black surface is a good emitter and absorber of radiation. A black surface absorbs all the radiation that falls on it, but does not reflect, and transmits it. The radiation that was refracted by the glass is absorbed by the black plate and converted to heat energy. Food cooks best in light-weight, dark, shallow, thin metal pots with tight fitting glass lid to hold heat and moisture which works best in solar cooker. The researcher chose glass lid to cover the cooking pot because it helps reduce convection of heat energy.

### **3.2.3 The Transparent Glass Plate**

For this research work, a shallow pot that is slightly larger than the food to be cooked is used. The four mirrors serve as reflectors. When beam of rays from the sun is incident on the mirror, it is reflected in the opposite direction in such a way that it is absorbed by the glass on top of the box which serves as the lid. For this thesis, a reflector mirror with thickness of 3.175mm was used. The dimension of the mirror used for the sides of the box was noted to have long and short length with equal height as 550mm × 430mm × 400mm.

Glass provides better performance efficiency than plastic. And there is reason to believe that under windy conditions, glass is preferred since it does not flap in the wind and pump heat out of the cooker. For this piece of work, the thickness of the plane glass cover used is 5 inches (127mm). The glass dimension was 585mm x 495mm. The box cooker was placed on top of a building for the box cooker to be heated faster since there are no interruptions at that height. A thermometer was used to measure the temperatures of the absorber plate in the box cooker and the ambient at different time intervals.

### **3.2.4 Cooking Glass Lid**

The method of convection application is at a very low rate using utensils with time require to cook hard food.

### **3.2.5 The Reflector Mirror Design/Connection**

The reflector mirror also called collectors were drawn out as depicted in Figure 3.6 on a four-flat piece, using light wood. The reflector mirrors were set out as they fit on top of the box and the sides guided with wooden frame. Screws were fixed on the sides of the wooden housing of the mirror. The screws on the outer corners of the wooden frame serves as a point where a loop is made at one end of the thread and tied to the screws and lase round the box to guide the frame of the reflectors from falling off. Two pair of hinges was used to hold the wooden frameto the top edge of the box with two pair of star screws nails. This makes the reflectors detachable when necessary, using a star screw driver when transporting it and could be safely packed together in a rack to avoid it being damaged.

### **3.2.6 Insulators**

These are materials with little or no conductivities which is sandwich between the solar box and the absorber plate. This is necessary because it reduces the rate of heat lost in the box. Examples of such insulators are; Newspaper, Air, sawdust, and foam. Among these insulators, foam was used in the construction of the solar box cooker.

### **3.2.7 Thermometer/Thermocouples**

These are devices that are used to measure the temperature of a body. The researcher made use of the 100<sup>0</sup>C Mercury in glass thermometer to measure the various temperatures required to cook food.

### 3.3 DESIGN EQUATIONS

These constitute the various formulas needed to compute for temperatures efficiencies and energies required to cook food.

The researcher considered the following in the design:

#### 3.3.1 Analysis of Efficiency of The Solar Box Cooker

$$\text{Efficiency} = \frac{\eta_0 - a_1(T_c - T_a) - a_2(T_c - T_a)^2}{E_e} \dots\dots\dots(1)$$

(Felix A. et al, 2002)

$\eta_0$  = efficiency of the collector at zero temperature difference between absorber plate temperature and ambient temperature.

$$\eta_0 = \alpha \tau F^1 \dots\dots\dots(2)$$

$\alpha$  = Absorption factor of absorber plate = 0.93.  $\tau$  = Transmission factor of cover = 0.895

$F^1$  = Absorber efficiency factor = 0.945

$$\eta_0 = \alpha \tau F^1 = 0.93 \times 0.895 \times 0.945 = 0.787$$

$a_1$  = Linear Heat Transfer coefficient = 2.6W/m<sup>2</sup>K

$a_2$  = Quadratic Heat Transfer Coefficient = 0.01W/m<sup>2</sup>K<sup>2</sup>       $E_e$  = Solar Irradiance = 1000W/m<sup>2</sup>

$T_c$  = Temperature of the absorber plate (collector plate)       $T_a$  = Ambient air Temperature of the SC surrounding.

#### 3.3.2 Efficiency of No-Loading (Stagnation) Temperature Test (Expt.1)

In experiment1, let take the average temperature for ambient ( $T_a$ ) and absorber plate ( $T_c$ ) to be  $T_a = 62^0C$ ,  $T_c = 62.7^0C$  respectively.

From (Eq.1)

$$\text{Efficiency} = \frac{\eta_o - a_1(T_c - T_a) - a_2(T_c - T_a)^2}{E_e}$$

$$\eta = \frac{0.787 - 2.6(T_c - T_a) - 0.01(T_c - T_a)^2}{1000}$$

Let assume  $T_a = 62^{\circ}\text{C}$   $T_c = 62.7^{\circ}\text{C}$

$$\eta = \frac{0.787 - 2.6(62.7 - 62) - 0.01(62.7 - 62)^2}{1000}$$

$$\eta = \frac{0.787 - 2.6(0.7) - 0.01(0.7)^2}{1000}$$

$$\eta = 0.787 - 0.00182 - 0.0000049$$

$\eta = 0.7851751$  or  $0.7852$  (efficiency at the stagnation stage).

### 3.3.3 The Percentage Efficiency at Loading Stage

Also, from (Eq.1)

$$\text{Percentage efficiency } (\% \eta) = \frac{\text{output efficiency}}{\text{input efficiency}}$$

$$\text{The output efficiency } (\eta) = \frac{\eta_o - a_1(T_c - T_a) - a_2(T_c - T_a)^2}{E_e}$$

$$\eta = \frac{0.787 - 2.6(T_c - T_a) - 0.01(T_c - T_a)^2}{1000}$$

If the  $T_a = 62^{\circ}\text{C}$   $T_c = 66^{\circ}\text{C}$  then,

$$\eta = \frac{0.787 - 2.6(66 - 62) - 0.01(66 - 62)^2}{1000}$$

$$\eta = \frac{0.787 - 2.6(4) - 0.01(4)^2}{1000}$$



$$\eta = 0.787 - 0.0104 - 0.00016$$

$$\eta = 0.787 - 0.01056 = 0.77644 \text{ or } 0.7764$$

$$\eta = 0.7764$$

$$\text{The input efficiency } (\eta) = \frac{0.787 - 2.6(T_c - T_a)}{1000} - \frac{0.01(T_c - T_a)^2}{1000}$$

NB: At the input level,  $T_a = T_c = 62^\circ\text{C}$

So, if at the input level  $T_a = 62^\circ\text{C}$ , then  $T_c = 62^\circ\text{C}$ . By substitution, input

$$\text{efficiency } (\eta) = \frac{0.787 - 2.6(62-62) - 0.01(62-62)^2}{1000}$$

$$\eta = \frac{0.787 - 2.6(0) - 0.01(0)^2}{1000 - 1000}$$

$$\eta = 0.787 - 0 - 0$$

$$\text{The input efficiency } (\eta) = 0.787 \text{ Efficiency } (\% \eta) = \frac{0.776}{0.787}$$

$$\eta = 0.986 \times 100\%$$

$$\text{Efficiency } (\eta) = 98.6\%$$

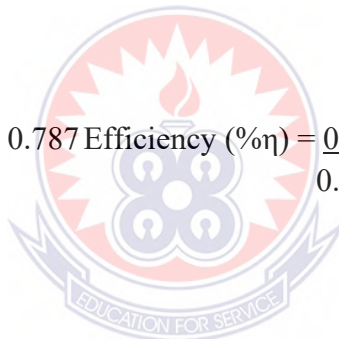

### 3.3.4 Computation of Energy from Collector Plate

The power/energy ( $\text{Js}^{-1}$ ) radiated by the collector plate/absorber plate is computed as:

From (Eq.2)

$$\text{Energy } (E) = \epsilon A \sigma T^4 c$$

$$\text{Area of the absorber plate surface } (A) = LB = 0.57055\text{m}^2$$

Length (L) = 0.5m, 0.445m, 0.41m; Breadth (B) = 0.44m, 0.41m, 0.41m, Area of the absorber plate ( $A_T$ ) =  $A_1 + A_2 + A_3$ .

$$A_1 = L \times B = 0.5 \times 0.44 = 0.22\text{m}^2, A_2 = 0.445 \times 0.41 = 0.18245\text{m}^2, A_3 = 0.41 \times 0.41 = 0.1681\text{m}^2.$$

$$A_T = 0.22 + 0.18245 + 0.1681 = 0.57055\text{m}^2.$$

If  $e = 1$ ,  $A = 0.57055\text{m}^2$ , Stefan's constant  $\bar{\sigma} = 5.67 \times 10^{-8} \text{Wm}^{-2}\text{k}^{-4}$ ,  $T_C$  = absorber plate temperature.

$$\text{When } T_C (\text{No - Loading}) = 62.7^\circ\text{C} = 62.7 + 273 = 335.7\text{k}.$$

If  $A_T = A$ , then by substitution

$$\text{Energy (E)} = eA\bar{\sigma}T^4 \text{c (Felix, A.P, karl-Heinz, R \& Martin, S (2002).}$$

$$= 1 \times 0.57055 \times 5.67 \times 10^{-8} \times (335.7)^4 = 410.849\text{J}.$$

### 3.3.5 Computation of Energy from Charcoal on Bright Days

$$H = m_c C_c(T_2 - T_1) \dots \dots \dots (3)$$

Mass of empty pan = 4g, mass of pan+ Charcoal = 36g, Mass of Charcoal = 36-4 = 32g.

$$\text{Where, } m_c = \text{mass of Charcoal} = 32\text{g}, = 0.032\text{Kg}$$

$$C_c = \text{heat capacity of Charcoal.} = 1\text{KJ/Kgk}, H = \text{Heat energy (KJ). } T_1 = 22^\circ\text{C (295K),}$$

$$T_2 = 74^\circ\text{C (347K). } (T_2 - T_1) = 347 - 295 = 52\text{k}$$

$$H = m_c C_c(T_2 - T_1) = 0.032 \times 1000 \times (347 - 295) = 32 \times 52 = 1664\text{J} = 1.664\text{KJ}$$

### 3.3.6 Computation of Energy from Gas on Bright Days

Mass of empty cylinder = 8kg (8000g), Mass of gas + cylinder = 11kg (11000g).

Mass of gas = 11- 8 = 3kg (3000g).

$$H = m_{\text{gas}} C_{\text{gas}}(T_2 - T_1) \dots \dots \dots (4)$$

$$H = ? \text{ KJ, } m_{\text{gas}} = 3\text{kg, } C_{\text{gas}} = 4576 \text{ J/K}, T_1 = 24^\circ\text{C (297K), } T_2 = 90^\circ\text{C (363K). } (T_2 - T_1) = 363 - 297 = 66\text{K}.$$

$$H = m_{\text{gas}} C_{\text{gas}} (T_2 - T_1) = 3 \times 4576 (363 - 297) = 3 \times 4576 \times (66) = 906048\text{J} = 906.048\text{KJ}.$$

### 3.3.7 Computation of Energy from Charcoal on Low Cloudy Days

From (Eqn.3)

$$H = m_c C_c(T_2 - T_1)$$

Mass of empty pan = 4g, mass of pan+ Charcoal = 36g, Mass of Charcoal = 36-4 = 32g.

Where,  $m_c$  = mass of Charcoal = 32g, = 0.032Kg

$C_c$  = heat capacity of Charcoal. = 1KJ/Kgk, H = Heat energy (KJ).  $T_1 = 14^{\circ}\text{C}$  (287K),

$T_2 = 62^{\circ}\text{C}$  (335K).  $(T_2 - T_1) = 335 - 287 = 48\text{K}$ .

$$H = m_c C_c(T_2 - T_1) = 0.032 \times 1000(335 - 287) = 32 \times 48 = 1536\text{J} = 1.536\text{KJ}.$$

### 3.3.8 Computation of Energy from Gas on Low Cloudy Days

Mass of empty cylinder = 8kg (8000g), Mass of gas + cylinder = 11kg (11000g).

Mass of gas = 11- 8 = 3kg (3000g).

From (Eqn.4)

$$H = m_{\text{gas}} C_{\text{gas}}(T_2 - T_1)$$

H = ? KJ,  $m_{\text{gas}} = 3\text{kg}$ ,  $C_{\text{gas}} = 4576 \text{ J/K}$ ,  $T_1 = 22^{\circ}\text{C}$  (295K),  $T_2 = 86^{\circ}\text{C}$  (359K).  $(T_2 - T_1) = 359 - 295 = 64\text{K}$ .

$$H = m_{\text{gas}} C_{\text{gas}}(T_2 - T_1) = 3 \times 4576 \times (359 - 295) = 3 \times 4576 \times 64 = 878592\text{J} = 878.592\text{KJ}.$$

### 3.3.9 Computation of Energy from Charcoal on High Cloudy Days

From (Eqn.3)

$$H = m_c C_c(T_2 - T_1)$$

Mass of empty pan = 4g, mass of pan+ Charcoal = 36g, Mass of Charcoal = 36-4 = 32g.

Where,  $m_c$  = mass of Charcoal = 32g, = 0.032Kg

$C_c$  = heat capacity of Charcoal. = 1KJ/Kgk,  $H$  = Heat energy (KJ).  $T_1 = 12^{\circ}\text{C}$  (285K),

$T_2 = 62^{\circ}\text{C}$  (335K),  $(T_2 - T_1) = (335 - 285) = 50\text{K}$

$H = m_c C_c(T_2 - T_1) = 0.032 \times 1000 \times (335 - 285) = 32 \times 50 = 1600\text{J} = 1.6\text{KJ}$

### 3.3.10 Computation of Energy from Gas on High Cloudy Days

Mass of empty cylinder = 8kg (8000g), Mass of gas + cylinder = 11kg (11000g). Mass

of gas = 11-8 = 3kg (3000g).

From (Eqn.4)

$H = m_{\text{gas}} C_{\text{gas}}(T_2 - T_1)$

$H = ? \text{ KJ}$ ,  $m_{\text{gas}} = 3\text{kg}$ ,  $C_{\text{gas}} = 4576 \text{ J/K}$ ,  $T_1 = 22^{\circ}\text{C}$  (295K),  $T_2 = 86^{\circ}\text{C}$  (359K).  $(T_2 - T_1) = (359 - 295) = 64\text{K}$ .

$H = m_{\text{gas}} C_{\text{gas}}(T_2 - T_1) = 3 \times 4576 \times (359 - 295) = 3 \times 4576 \times 64 = 878592\text{J} = 878.592\text{KJ}$

## 3.4 METHODS OF HEAT TRANSFER

There are three main methods of heat transfer namely; Conduction, Radiation and Convection. Out of these three methods, only Radiation and Conduction were considered in the construction and usage of the Solar Box Cooker.

### 3.4.1 Radiation

Radiation is the process of Solar Energy propagating from the sun into the Solar Box Cooker and its surrounding. This method does not need any material medium for its propagation. The Radiant Energy reaching the Earth is redirected by the four reflectors into the box through the glass lid.

### **3.4.2 Conduction**

Conduction is the process of allowing heat energy to pass through a good Conductor/semi- conductor. The absorber plate used in this construction is Alu Zinc metal which is a conductor. So, when the Solar Radiation comes in contact with the Alu Zinc which is painted black, it has the ability to absorb, retain and radiate the heat gradually to support the one captured by the Concentrator in order to boil its content. The conductivity of these two metals (Alu zinc and silver concentrator) is high because both are painted black with oil paint which has the ability to absorb and retain high amount of heat energy. Also, heat is transferred from the burning flame of the charcoal or gas via the cooking pot to boil the food.

### **3.4.3 Principle of Operation of Solar Cooker**

Radiant energy from the sun falls on the reflector (collectors) found on the four corners of the box at a given angle and directed to the lenses (Plano glass) covering the top most portion of the box. The lens trapped the heat energy inside the box to form a greenhouse effect. The absorber plate (Al plate painted black) stored the radiant energy at the same time the blackened concentrator or pot makes use of the energy to boil the food. The Aluminum foil gradually releases the heat energy to support and supply to the pot to boil its substances when source of supply the radiant energy is gradually going down. The white paint reflects the radiant energy back to be trapped in the box and to reduce waste of it.

Heat is lost due to how the solar cooker is designed and made. If the insulating material is not able to stop the heat energy trapped inside the box, heat will be lost to the surroundings which will gradually affect the boiling rate. Also, if the reflector's lenses are not properly positioned, heat energy can also get lost. Heat energy can get lost due

to the change of weather condition. This can occur when the temperature is high between 12pm to 3pm and later there is sudden down pour of rain, heat can get disappeared. This can slow down the boiling process due to heat lost.

### 3.5 DESIGN OF SOLAR BOX COOKER

Figure 3.1 shows a completed Solar Box Cooker. The box constitutes three parts namely; top development, base, and reflectors. These parts are being represented with letter A, B, and C respectively as shown in the figure 3.1 below. This assembly drawing serves as a guide to help the researcher to come out with the required constructed Solar Box Cooker.

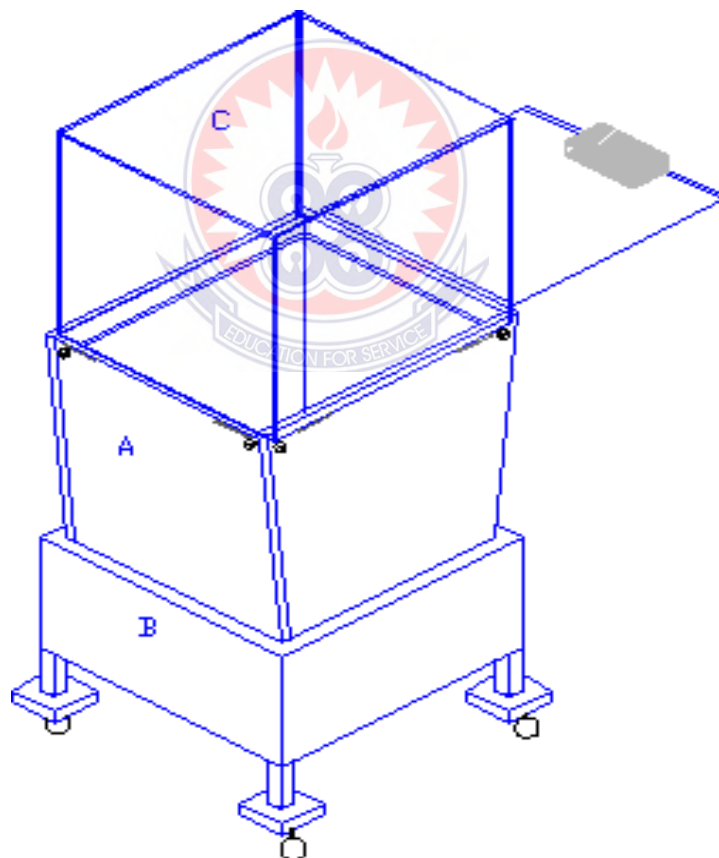

**Figure 3. 1: Solar Box Cooker**

Figure 3.2 is the exploded view of the entire solar box cooker. It has two main sections namely the top development (A), the base (B), reflectors, glass cover, stands,

footings and rolling tyres. The top development constitutes four side walls with different dimensions. On top of each wall there are reflectors that divert sun rays into the box covered with glass lid. The base has four side walls which is mounted on a stand at each corner of the base. The stands are resting on a footing at each corner. On each footing, there are rolling tyres for easy movement.

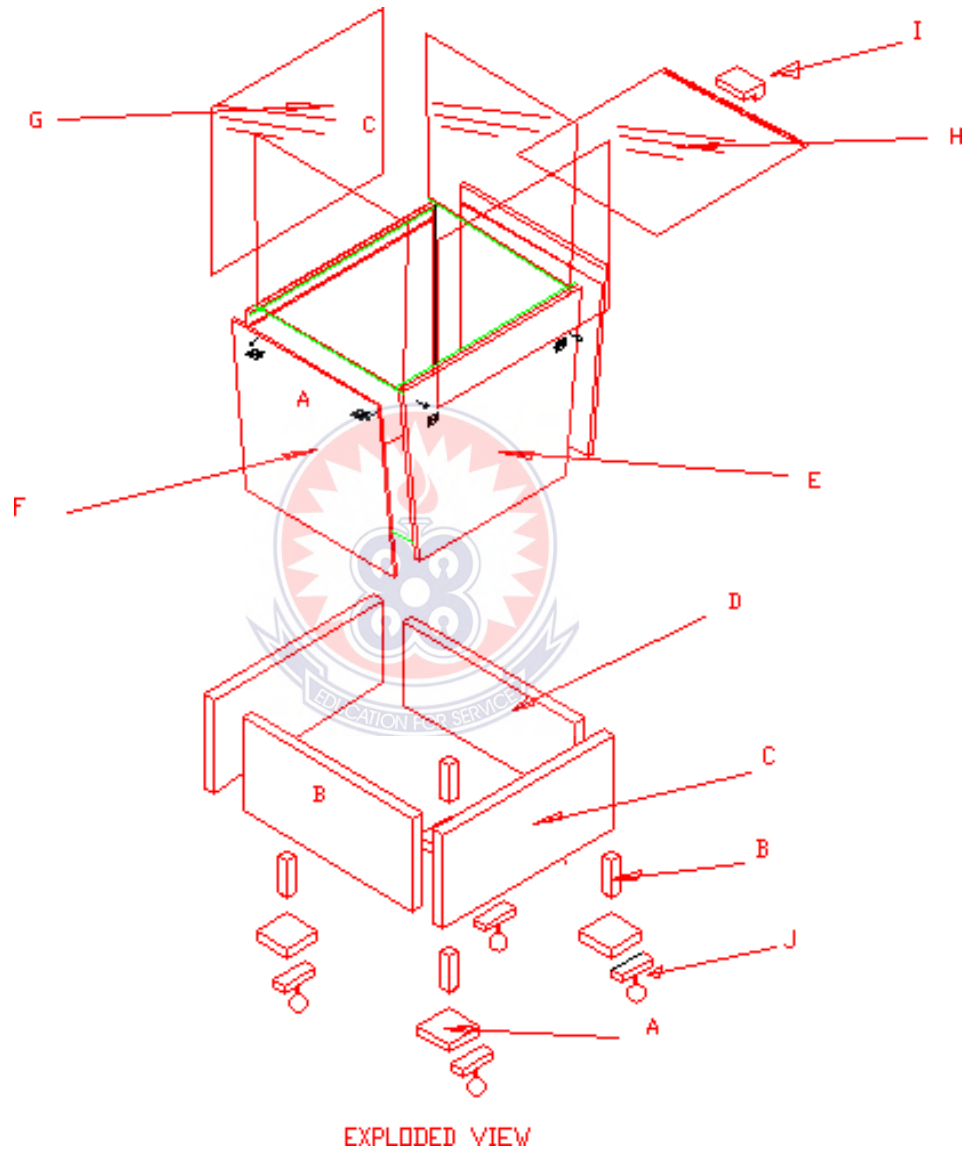

**Figure 3. 2: Exploded View of the SBC**

Figure 3.3 is the detailed drawings of the solar box cooker. The drawings constitute part A which represents the top development and part B which represents the base. Part A and B have it dimensions measured in millimeters.

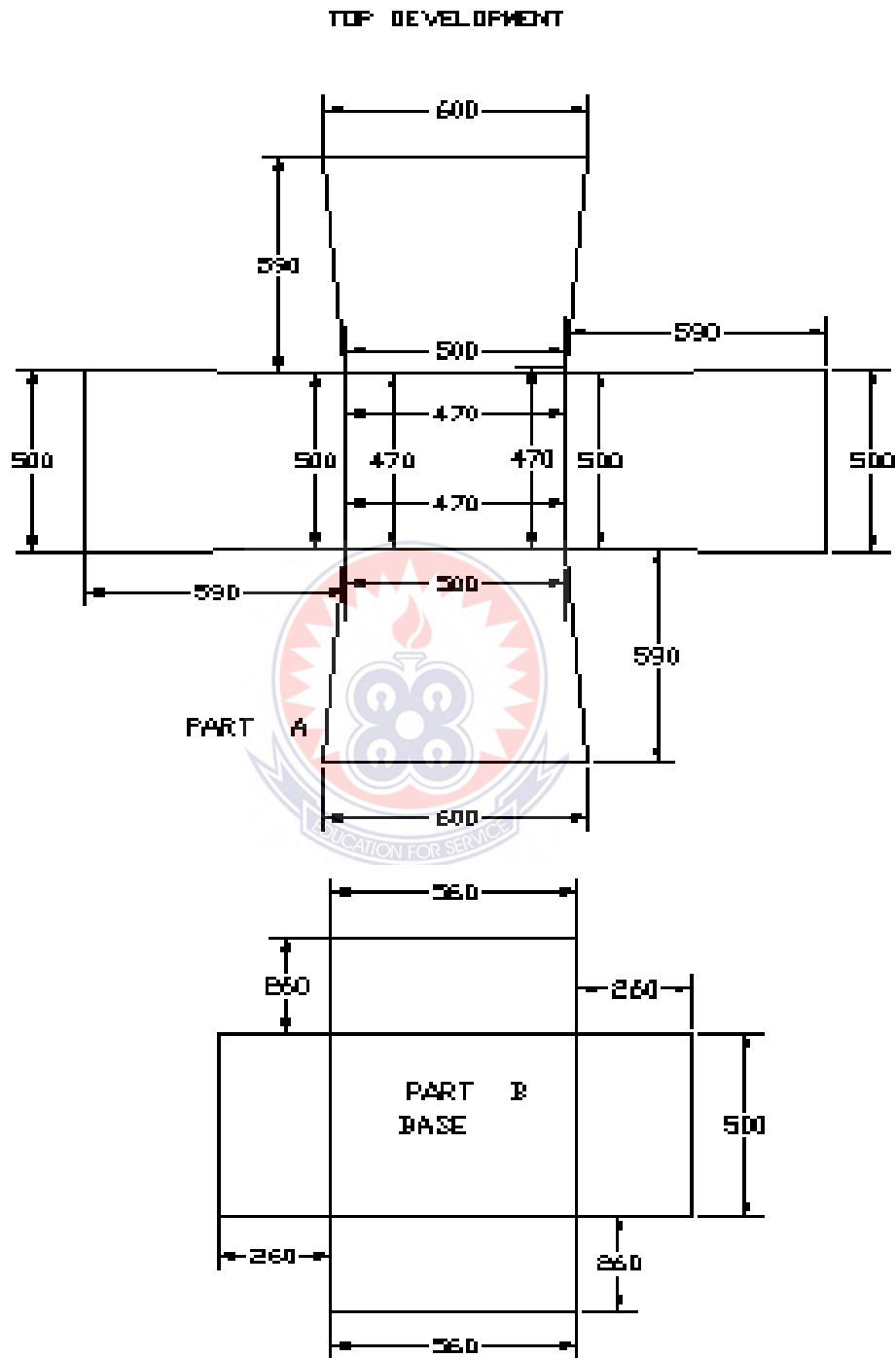
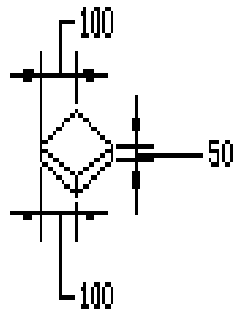

**Figure 3. 3: Detailed Drawing of SBC**

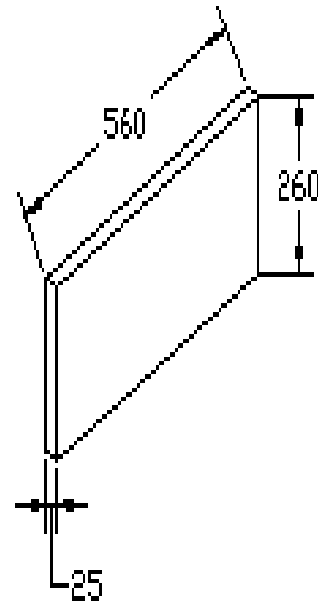

Figure 3.4 shows part A representing the footing, B representing the stands, C and D representing the two side views of the base.

Part A Footing-4-DFF



Part - C 2-DFF  
Side Views of the Base



Part - B 4-DFF

Stand

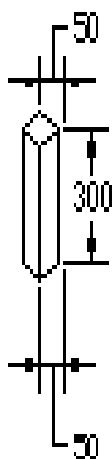

Part - D 2-DFF  
Side Views of the Base

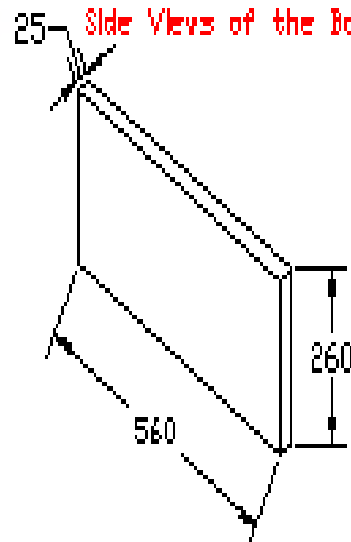
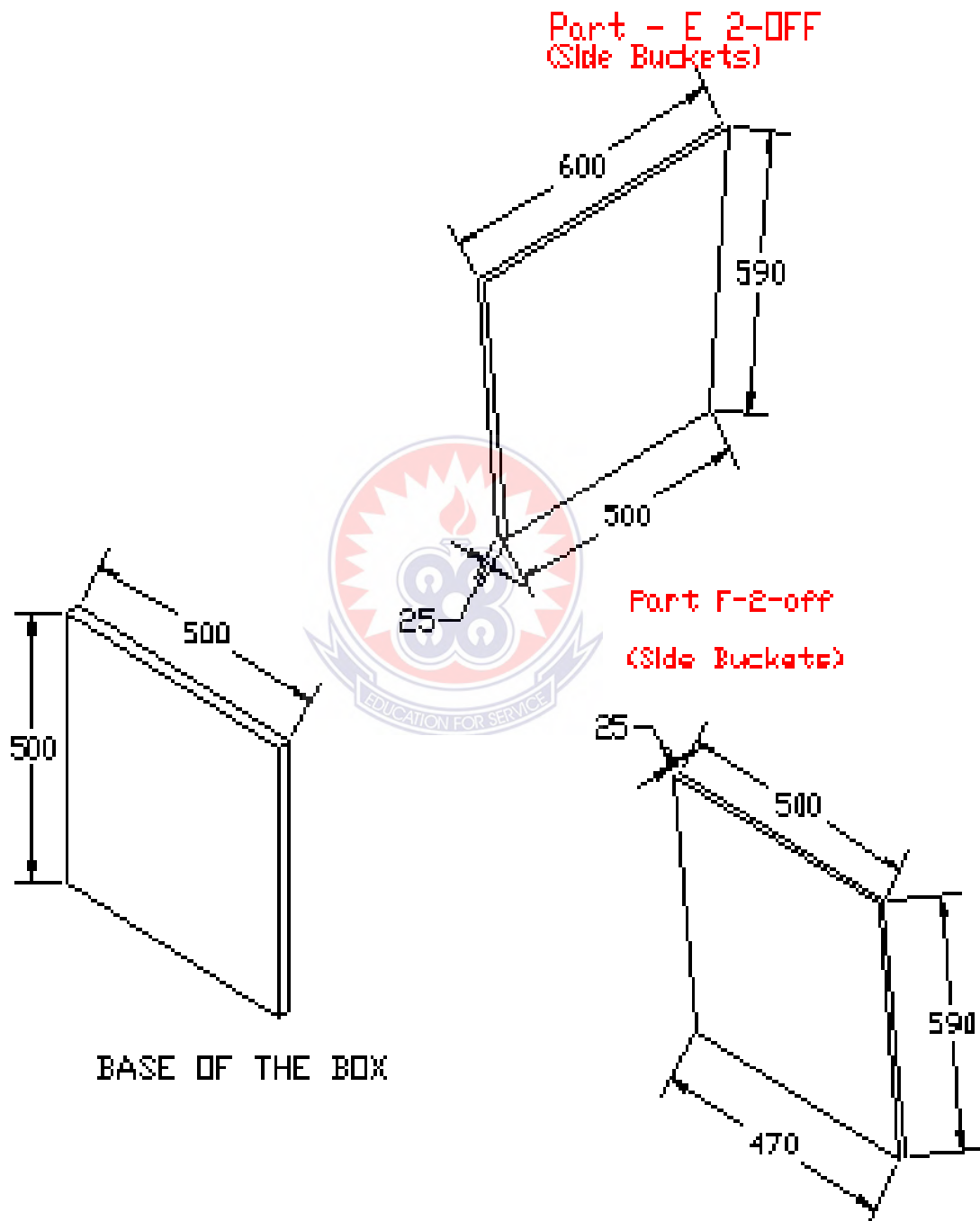

Figure 3. 4: Side views, Stands and Footings of the SBC

Figure 3.5 shows the two opposite side buckets of SBC with different dimensions which has a square base  $500\text{mm} \times 500\text{mm}$ . These parts will help form a completed SBC.



**Figure 3. 5: The Four (4) Side Walls of the Box and it's base**

Figure 3.6 represents the reflectors, wooden frame for reflectors, wooden handle for glass cover, glass cover, and rolling stands which forms part of the solar box cooker.

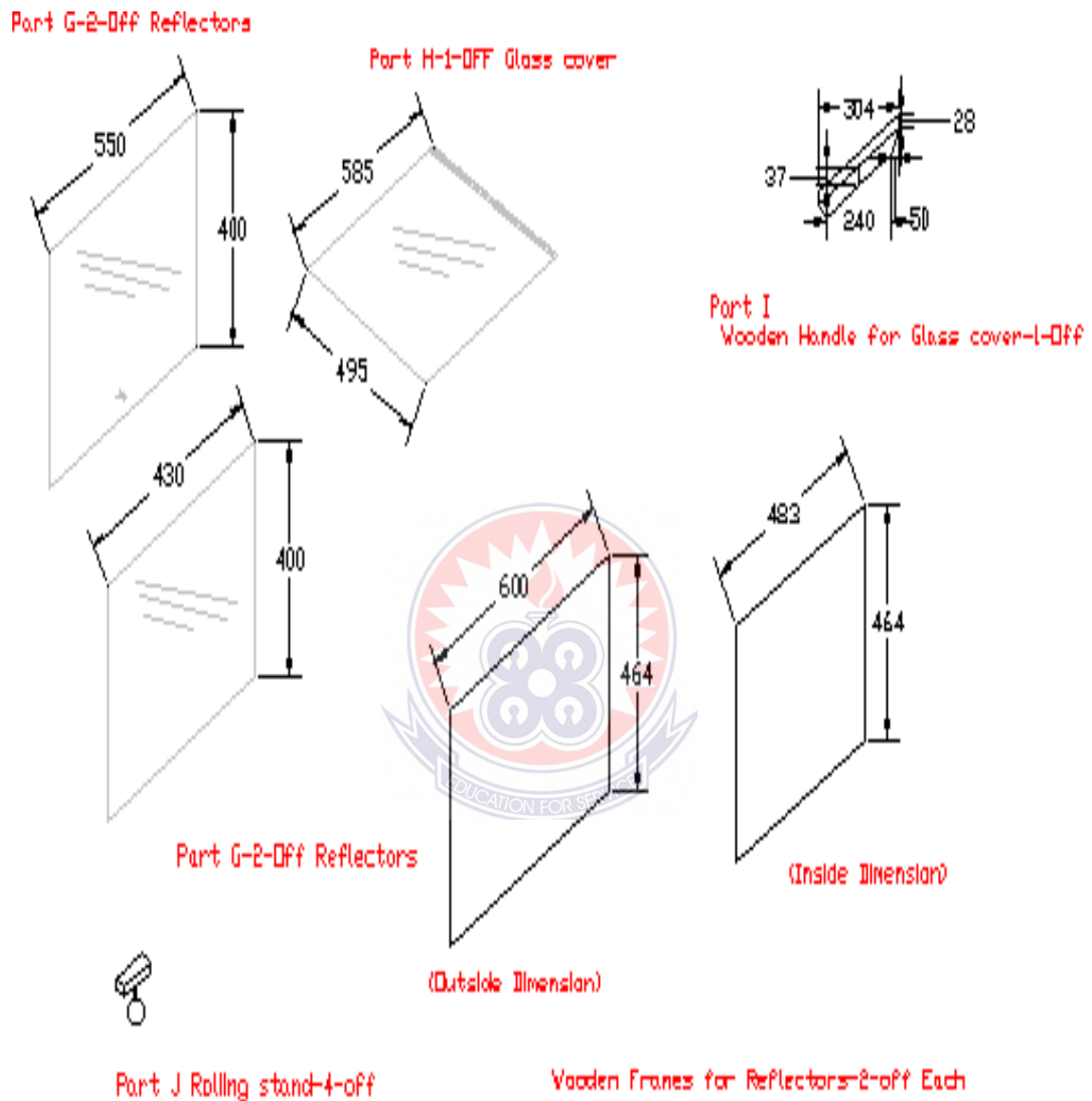

**Figure 3. 6: Reflectors, Glass Cover, Wooden frame for reflectors, and Rolling stands**

Figure 3.7 shows the constructed solar box cooker. This is one side view of the solar box cooker. This box will help the researcher to carry out the temperature tests under the various weather conditions.



**Figure 3. 7: Side View of a Solar Box Cooker**

Figure 3.8 shows the inner part of the SBC. It is painted black to be able to absorb and retain heat for boiling food.



**Figure 3. 8: Inside View of Solar Box Cooker Without Concentrator**

Figure 3.9 shows the top view of the constructed Solar Box Cooker. It has both the concentrator and the 100<sup>0</sup>C thermometer. The edges of the box are painted white to reflect heat energy back to the box via the glass lid.



**Figure 3. 9: (a) Solar Box Cooker for Temperature Profiling with Concentrator**



Figure 3.10 shows the top view of the concentrator. The outer part of it is painted black to retain heat energy.



**Figure 3. 10: Concentrator – Inside Top View**

Figure 3.11 is the back of the concentrator which is painted black to absorb and retain heat energy. Attached is the 100<sup>0</sup>C Mercury in glass thermometer.



**Figure 3. 11 Concentrator – Blackened Back View**

Figure 3.12 is the top view of the constructed Solar Box Cooker with the concentrator and thermometer. It has a sliding glass with one end having a wooden handle. The sliding glass serves as the glass lid which trap the heat energy in the box made available for food to boil. The reflected mirrors are hinged at the edges of the box to reflect radiant energy into the box through the glass cover/lid. The concentrator is covered with its lid painted black as shown in the figure 3.12.



**Figure 3. 12: Solar Box Cooker for Temperature Profiling with Concentrator and Glass cover sliding open**



Figure 3.13 represents one of the setups of the experiment where the temperature required to heat or boil the food is measured using 100<sup>0</sup>C Mercury in glass thermometers. Charcoal was used as fuel and the coal pot was placed at a corner to reduced wind interruption.



**Figure 3. 13: Coal Pot/Charcoal Stove for Temperature Profiling with Cooking Pot**

Figure 3.14 represents one of the setups of the experiment where the temperature required to heat or boil the food is measured using 100<sup>0</sup>C Mercury in glass thermometers. Gas was used as fuel and the gas burner was placed at a corner to reduced wind interruption.



**Figure 3. 14: Gas Stove for Temperature Profiling with Cooking Pot**

### **3.5 DESIGN AND OPERATION**

#### **3.6.1 Box Space:**

A solar box cooker should be made such that it can serve the purpose of the design.

The author chose a wider dimension of the box as 600mm x 500mm x 590mm in order to accommodate small and large cooking pot to be able to cook food to feed a large family at once instead of cooking the food in bits or using two or more solar cookers to cook one food as suggested by Yaffe, Linda and Fredrick, 2007 in their literature.

Scientifically, it is believed that when the aperture (area) of a box is large, it has the ability to allow more heat energy to pass through it more easily as compare to smaller aperture. So, the author chose a wider dimension for the design of (SBC) in order to trap and retain more radiant energy that comes from the sun and propagate through an open space. As more of the radiant energy is trapped in the box, more greenhouse effect of heat energy is converted at the upper aperture of the box and through the absorber plate, energy gradually move down the base of the concentrator that holds the food. The author chose 0.3mm aluminum and a silver cooking pot of which both were painted black with oil paint which has the ability to absorb, and retain more heat energy.

The researcher chose the thickness of 3.175mm reflecting mirrors and 127mm sliding glass with a wider dimension in order to be able to re-direct and retain more radiant energy. The sliding glass has the ability to prevent more heat loss through it walls, hence enough energy is made available for cooking food.

The experimenter also considered the following in his design and construction of the Solar Box Cooker:

- If the box needs to be moved often, use rolling tyres at the footing close to the base to make movement easier when locating it to where sun is available.
- Do not use too large plywood, for it makes re-locating the SBC tedious. The box should be spacious enough to accommodate the cooking pot.
- Use light cooking pot with tight lid, for too heavy cooking pot delay the cooking process.
- Use preferably tight glass lid, for it does not allow steam to get escape from the cooking pot/concentrator.

### **3.6.2 Solar Collection Area to Box Volume Ratio:**

Everything else being equal, the greater the solar collection area of the box relative to the heat loss area of the box, the higher the cooking temperatures will be. Given two boxes that have solar collection areas of equal size and proportion, the one that is of small depth will be hotter because it has small heat loss area.

### **3.6.3 Solar Box Cooker Proportion:**

A solar box cooker facing the noon sun should be longer in the east or west dimension to make better use of the reflector over a cooking period of several hours. As the sun travels across the sky, this configuration effects in engulfing a large amount of Infra-red radiations resulting in consistent and stable cooking temperature. With square cookers or ones having the longest dimension north or south, a greater percentage of the early morning and late afternoon sunlight is reflected from the reflector to the ground, missing the box collection area. (Figure 3.18) Reflector four (4) reflectors (collectors) are employed to bounce additional light into the solar box in order to increase cooking temperature. Although it is possible to use solar cooker without

reflectors in equatorial when the sun is mostly overhead, reflectors increase cooking performance significantly in temperate regions of the world.

### **3.6.4 Solar Box Cooker Operation**

One of the beauties of solar box cookers is their ease of operation. For mid-day cooking slightly less than 30° N - 30° S latitude, solar box cookers with no reflector need little repositioning to face the sun as it moves across the mid-day sky. The box faces up and the sun is high in the sky for a good part of the day. Box with reflectors can be positioned toward the morning or afternoon sun to do the cooking at those times of day. (Chen et al, 1995) Solar box cookers used with reflectors in the temperate zones do operate at higher temperatures if the box is repositioned to face the sun in an hour or a little more time. This shifting of position becomes less necessary as the east to west dimension of the box increases relative to the north to south orientation (Figure 3.18).

Solar radiation falling in enclosed spaces gets collected naturally. But when a metal parabolic collector blackened for maximum quantum efficiency was placed inside the solar cooker, there exists a possibility when by the inclusion of a parabolic concentrator, there could be an increase in efficiency of the infra-red rays collected (Figure 3.9, 3.10, 3.11). Profiling studies with and without the concentrator were done and a detailed test of the results were equally performed (Cheema L.S, 1984).

## **CHAPTER FOUR**

### **RESULTS AND DISCUSSION**

#### **4.0 INTRODUCTION**

The researcher presents his data which was obtained using solar box cooker, coal pot, gas cylinder and burner. The infra-red radiation, charcoal and gas were used as fuel. The various temperature testing was carried out and presented in the form of figures. Also, the results of the study were discussed in this chapter. The discussion of results was based on the three (3) different cookers namely; solar box cooker, gas cooker and coal pot. The discussions of results were based on data collected.

The experiment was conducted under two main set-ups for solar box cooker and the other two (2) set-ups for gas and charcoal for which each outcome was discussed.

#### **4.1 SOLAR COOKER PROFILING**

The profiling studies were carried out on the internal temperature gradient and ambience of the cooking chamber inside the solar cooker. A thermometer with a maximum calibration of 100°C (Mercury in glass thermometer) was used to record the temperature from morning till evening or till the availability of solar radiation (Garg et al, 1978). In the first place the readings were taken with and without the concentrator on many specific occasions namely: 1. Bright Day 2. Low Cloudy day 3. Highly cloudy day.

These three main weather conditions captioned above were captured under two main headings namely: No-loading Temperature Test (Without concentrator) and Loading Temperature Test (with concentrator).



## 4.2 NO-LOADING TEMPERATURE TEST (WITHOUT CONCENTRATOR)

### 4.2.1 Bright Day

Figure 4.1 shows the temperature recorded under bright day/sun light weather condition. The graph has two columns. The vertical column shows the values for temperature in Degree Celsius and the horizontal columns shows the time intervals in minutes. The researcher chose to use two colors to distinguish between the temperature for absorber plate and ambient. The researcher used red color to represent ambient temperature and blue color to represent absorber plate temperature.

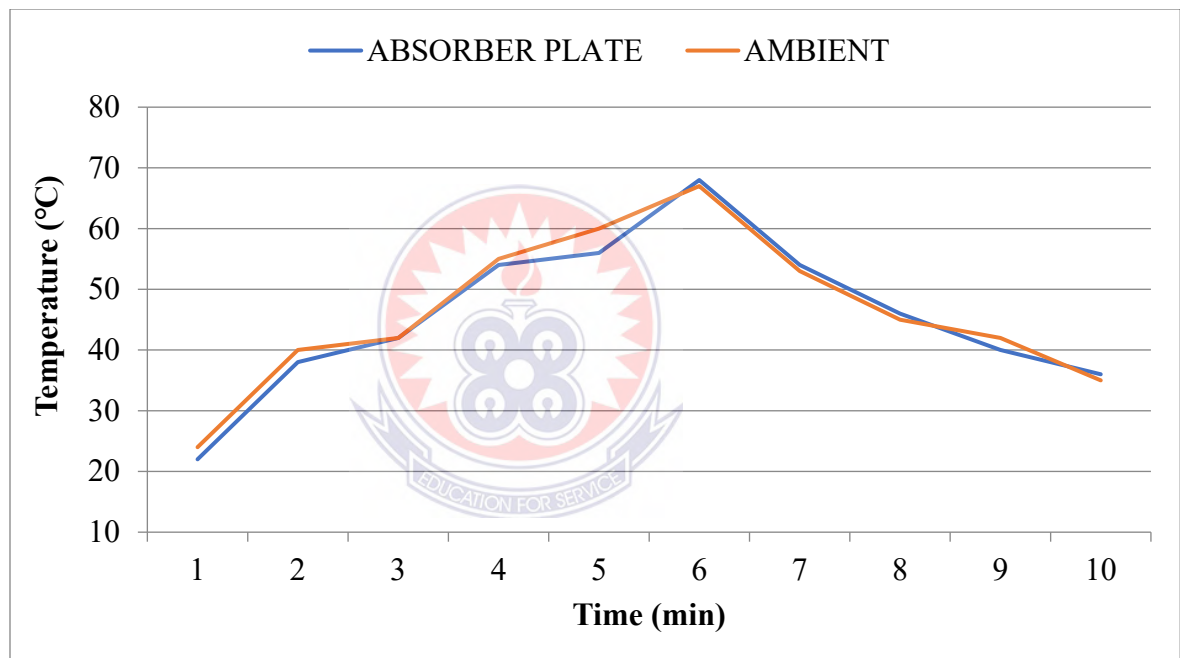

**Figure 4. 1: Solar Box Cooker Without Metallic Concentrator on a Bright Day (Max 68°C)**

From figure 4.1 above, the researcher recorded the least temperature to be 22°C for absorber plate whereas in the case of ambient he recorded 24°C. Both took the time interval of one minute. In two minutes, absorber plate recorded the temperature of 38°C whereas ambient recorded 40°C. In three minutes, the absorber plate recorded 42°C whereas ambient recorded the same temperature and time intervals. In four

minutes, absorber plate recorded  $54^{\circ}\text{C}$  whereas ambient recorded  $55^{\circ}\text{C}$  within the same time intervals. In five minutes, absorber plate and ambient recorded the temperature of  $56^{\circ}\text{C}$  and  $60^{\circ}\text{C}$  respectively. In six minutes, absorber plate and ambient recorded  $68^{\circ}\text{C}$  and  $67^{\circ}\text{C}$  respectively been the maximum temperatures reach before declining (cooling). In seven minutes, absorber plate and ambient recorded  $54^{\circ}\text{C}$  and  $53^{\circ}\text{C}$  respectively. In eight minutes, absorber plate recorded the temperature of  $46^{\circ}\text{C}$  and ambient recorded  $45^{\circ}\text{C}$ . In nine minutes, absorber plate recorded  $40^{\circ}\text{C}$  whereas ambient recorded  $42^{\circ}\text{C}$ . In ten minutes, absorber plate recorded  $36^{\circ}\text{C}$  whereas ambient  $35^{\circ}\text{C}$ .





#### 4.2.2 Low Cloudy Days

Figure 4.2 shows the temperature recorded under low cloudy day weather condition.

The graph has two columns. The vertical column shows the values for temperature in Degree Celsius and the horizontal columns shows the time intervals in minutes. The researcher chose to use two colors

to distinguish between the temperature for absorber plate and ambient. The researcher used red color to represent ambient temperature and blue color to represent absorber plate temperature.

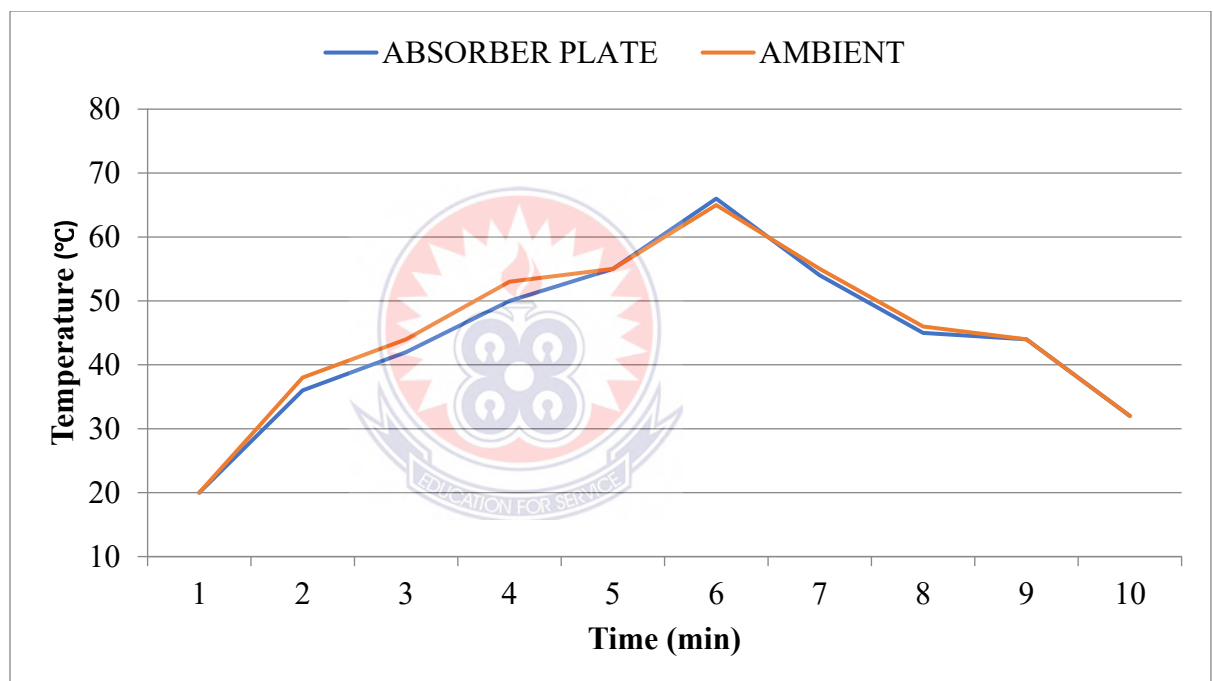

**Figure 4. 2: Solar Box Cooker Without Metallic Concentrator on a Low Cloudy Day (Max 66°C)**

From figure 4.2 above, the researcher recorded the least temperature to be 20°C for both absorber plate and ambient. Both took the time interval of one minute. In two minutes, absorber plate recorded the temperature of 36°C whereas ambient recorded 38°C at the same time. In three minutes, the absorber plate recorded 42°C whereas ambient recorded 44°C temperature. In four minutes, absorber plate recorded 50°C

whereas ambient recorded 53<sup>0</sup>C within the same time intervals. In five minutes, both absorber plate and ambient recorded the same temperature of 55<sup>0</sup>C. In six minutes, absorber plate and ambient recorded 66<sup>0</sup>C and 65<sup>0</sup>C respectively been the maximum temperatures reach for each case before declining (cooling). In seven minutes, absorber plate and ambient recorded 54<sup>0</sup>C and 55<sup>0</sup>C respectively. In eight minutes, absorber plate and ambient recorded 45<sup>0</sup>C and 46<sup>0</sup>C respectively. In nine minutes, both absorber plate and ambient recorded 44<sup>0</sup>C. In ten minutes, both absorber plate and ambient recorded 32<sup>0</sup>C.

#### 4.2.3 Highly Cloudy Day

Figure 4.3 shows the temperature recorded under High cloudy day weather condition. The graph has two columns. The vertical column shows the values for temperature in Degree Celsius and the horizontal column shows the time intervals in minutes. The researcher chose to use two colors to distinguish between the temperature for absorber plate and ambient. The researcher used red color to represent ambient temperature and blue color to represent absorber plate temperature.

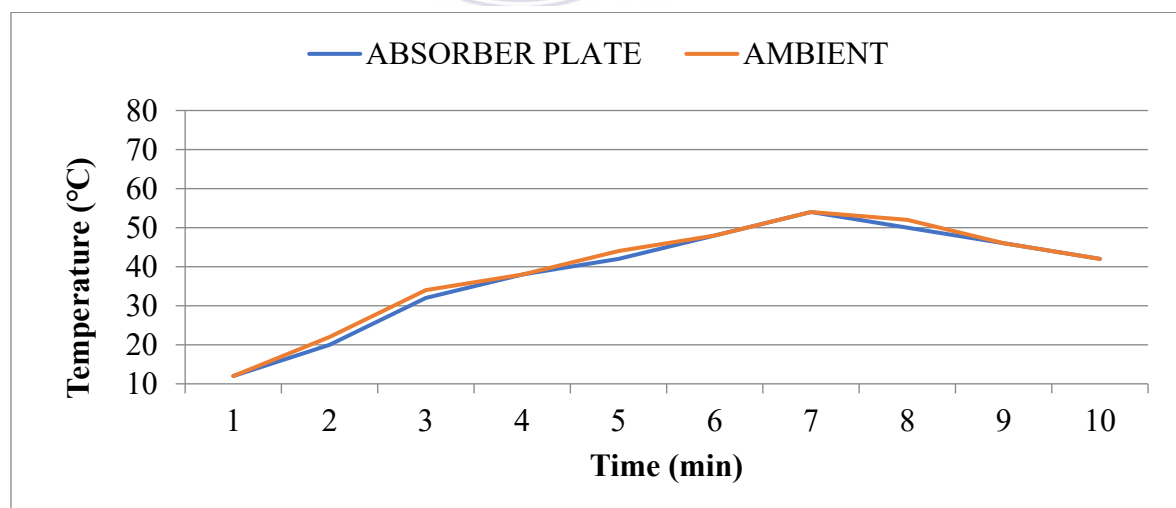

**Figure 4. 3: Solar Box Cooker Without Metallic Concentrator on a Highly Cloudy Day (Max 54°C)**

From figure 4.3, the researcher recorded the least temperature for both absorber plate and ambient in one minute to be 12<sup>0</sup>C. In two minutes, absorber plate recorded the temperature of 20<sup>0</sup>C whereas ambient recorded 22<sup>0</sup>C at the same time. In three minutes, the absorber plate recorded 32<sup>0</sup>C whereas ambient recorded 34<sup>0</sup>C temperature in the same time intervals. In four minutes, absorber plate and ambient recorded 38<sup>0</sup>C. In five minutes, absorber plate and ambient recorded the temperature of 42<sup>0</sup>C and 44<sup>0</sup>C respectively. In six minutes, absorber plate and ambient recorded 48<sup>0</sup>C. In seven minutes, absorber plate and ambient recorded 54<sup>0</sup>C been the maximum temperature. In eight minutes, absorber plate and ambient recorded 50<sup>0</sup>C and 52<sup>0</sup>C respectively. In nine minutes, absorber plate and ambient recorded 46<sup>0</sup>C. In ten minutes, absorber plate and ambient recorded 42<sup>0</sup>C.

### **4.3 LOADING TEMPERATURE TEST (WITH CONCENTRATOR)**

#### **4.3.1 Bright Day/Sun Light**

Figure 4.4 shows the temperature recorded under bright day weather condition. The graph has two columns. The vertical column shows the values for temperature in Degree Celsius and the horizontal columns shows the time intervals in minutes. The researcher chose to use two colors to distinguish between the temperature for absorber plate and ambient. The researcher used red color to represent ambient temperature and blue color represents absorber plate temperature.

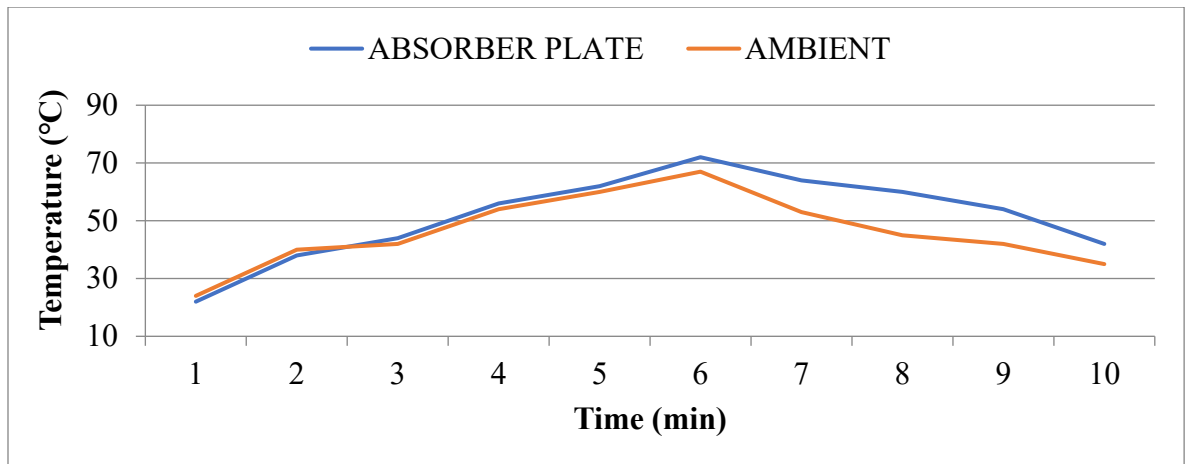

**Figure 4. 4: Solar Box Cooker with Metallic Concentrator on a Bright Day (Max 72°C)**

Figure 4.4, the researcher recorded the least temperature to be 22°C, 24°C for absorber plate and ambient respectively. Both took the time interval of one minute. In two minutes, absorber plate recorded the temperature of 38°C whereas ambient recorded 40°C. In three minutes, the absorber plate recorded 44°C whereas ambient recorded 42°C. In four minutes, absorber plate recorded 56°C whereas ambient recorded 54°C. In five minutes, absorber plate recorded 62°C and ambient recorded 60°C. In six minutes, absorber plate and ambient recorded 72°C and 67°C respectively been the maximum temperatures for each case before declining (cooling). In seven minutes, absorber plate and ambient recorded 64°C and 53°C respectively. In eight minutes, absorber plate and ambient recorded 60°C and 45°C respectively. In nine minutes, absorber plate recorded 54°C and ambient recorded 42°C. In ten minutes, absorber plate recorded 42°C and ambient recorded 35°C.

### 4.3.2 Low Cloudy Day

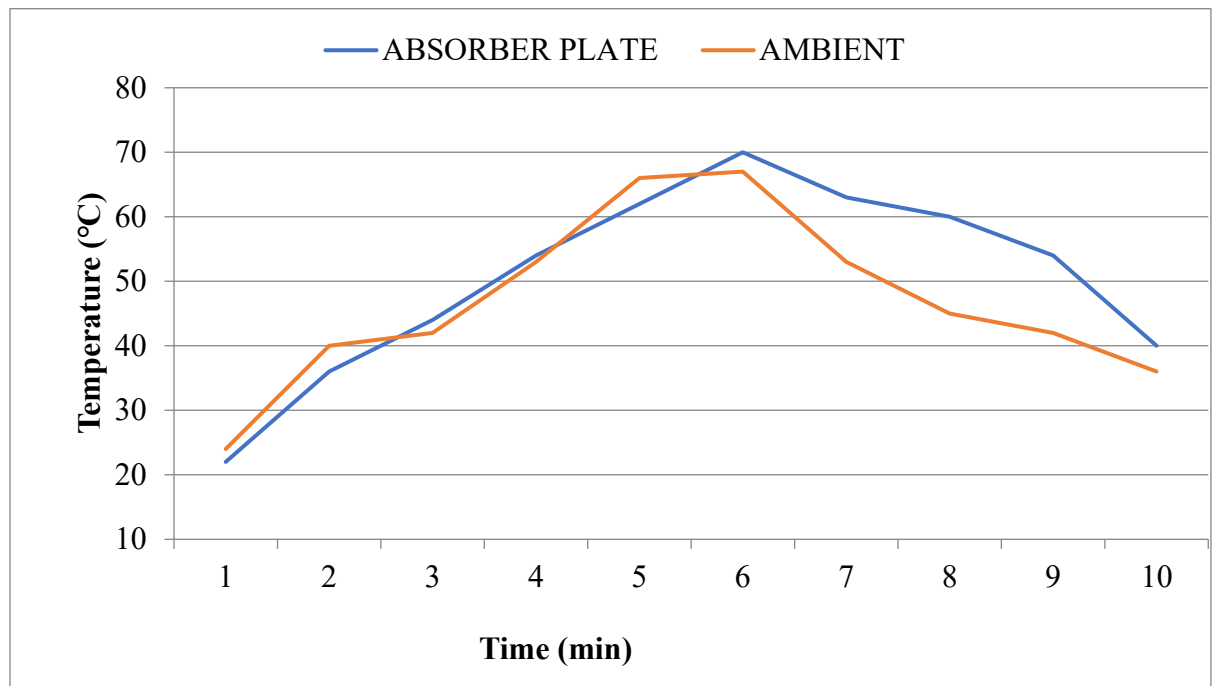

**Figure 4. 5: Solar Box Cooker with Metallic Concentrator on a Low Cloudy Day (Max 70°C)**

Figure 4.5 shows the temperature recorded under low cloudy day weather condition. The graph has two columns. The vertical column shows the values for temperature in Degree Celsius and the horizontal columns shows the time intervals in minutes. The researcher chose to use two colors to distinguish between the temperature for absorber plate and ambient. The researcher used red color to represent ambient temperature and blue color to represent absorber plate temperature. From figure 4.5 above, the researcher recorded the least temperature to be 22°C for absorber plate and 24°C for ambient. Both took the time interval of one minute. In two minutes, absorber plate recorded the temperature of 36°C whereas ambient recorded 40°C. In three minutes, the absorber plate recorded 44°C whereas ambient recorded 42°C temperature. In four minutes, absorber plate recorded 54°C whereas ambient recorded 53°C within the same time intervals. In five minutes, absorber plate recorded 62°C and

ambient recorded 66<sup>0</sup>C. In six minutes, absorber plate and ambient recorded 70<sup>0</sup>C and 67<sup>0</sup>C respectively been the maximum temperatures for each case before declining (cooling). In seven minutes, absorber plate and ambient recorded 63<sup>0</sup>C and 53<sup>0</sup>C respectively. In eight minutes, absorber plate recorded 60<sup>0</sup>C and ambient recorded 45<sup>0</sup>C. In nine minutes, absorber plate recorded 54<sup>0</sup>C and ambient recorded 42<sup>0</sup>C. In ten minutes, absorber plate recorded 40<sup>0</sup>C and ambient recorded 36<sup>0</sup>C.

#### 4.3.3 Highly Cloudy Day

Figure 4.6 shows the temperature recorded under low cloudy day weather condition. The graph has two columns. The vertical column shows the values for temperature in Degree Celsius and the horizontal columns shows the time intervals in minutes. The researcher chose to used two colors to distinguish between the temperature for absorber plate and ambient. The researcher used red color to represent ambient temperature and blue color to represent absorber plate temperature.

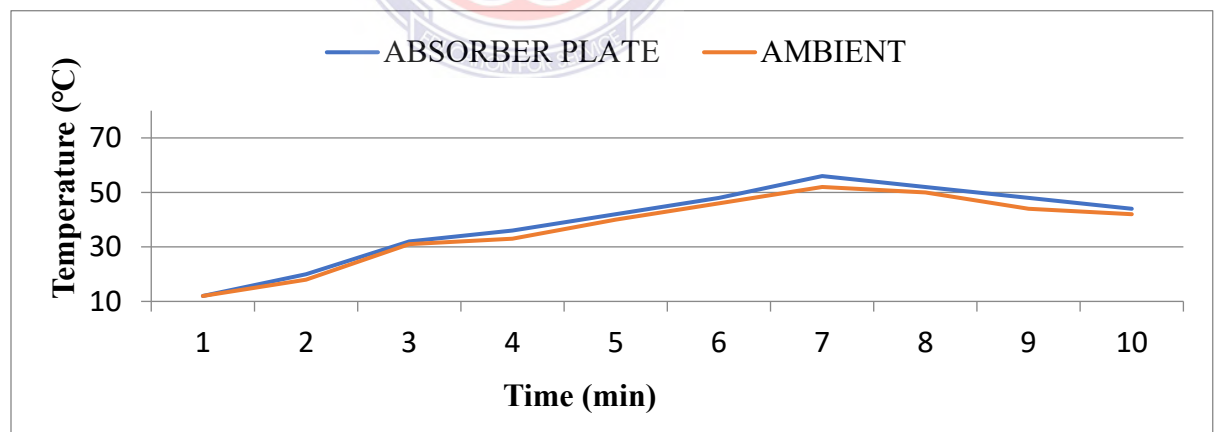

**Figure 4. 6: Solar Box Cooker with Metallic Concentrator on a Highly Cloudy Day (Max 56°C)**

From figure 4.6 above, the researcher recorded the least temperature to be 12<sup>0</sup>C for both absorber plate and ambient. Both took the time interval of one minute. In two minutes, absorber plate recorded the temperature of 20<sup>0</sup>C whereas ambient recorded 18<sup>0</sup>C. In three minutes, the absorber plate recorded 32<sup>0</sup>C whereas ambient recorded 31<sup>0</sup>C temperature. In four minutes, absorber plate recorded 36<sup>0</sup>C whereas ambient recorded 33<sup>0</sup>C. In five minutes, absorber plate recorded 42<sup>0</sup>C and ambient recorded the temperature of 40<sup>0</sup>C. In six minutes, absorber plate recorded 48<sup>0</sup>C and ambient recorded 46<sup>0</sup>C respectively. In seven minutes, absorber plate recorded 56<sup>0</sup>C and ambient recorded 52<sup>0</sup>C. In eight minutes, absorber plate and ambient recorded 52<sup>0</sup>C and 50<sup>0</sup>C respectively. In nine minutes, absorber plate recorded 48<sup>0</sup>C and ambient recorded 44<sup>0</sup>C. In ten minutes, absorber plate recorded 44<sup>0</sup>C and ambient recorded 42<sup>0</sup>C.

#### **4.4 LOADING TEMPERATURE TEST FOR CHARCOAL AND GAS**

##### **4.4.1 Temperature Testing for Gas and Charcoal for Bright Day**

Figure 4.7 represents the temperature graph for both gas and charcoal. The graph has two columns. The vertical column shows the values for temperature in degree Celsius and the horizontal columns shows the time intervals in minutes. The researcher chose to use two colors to distinguish between the temperature for gas and charcoal. The researcher used red color to represent temperature for charcoal and blue color to represent temperature for gas.

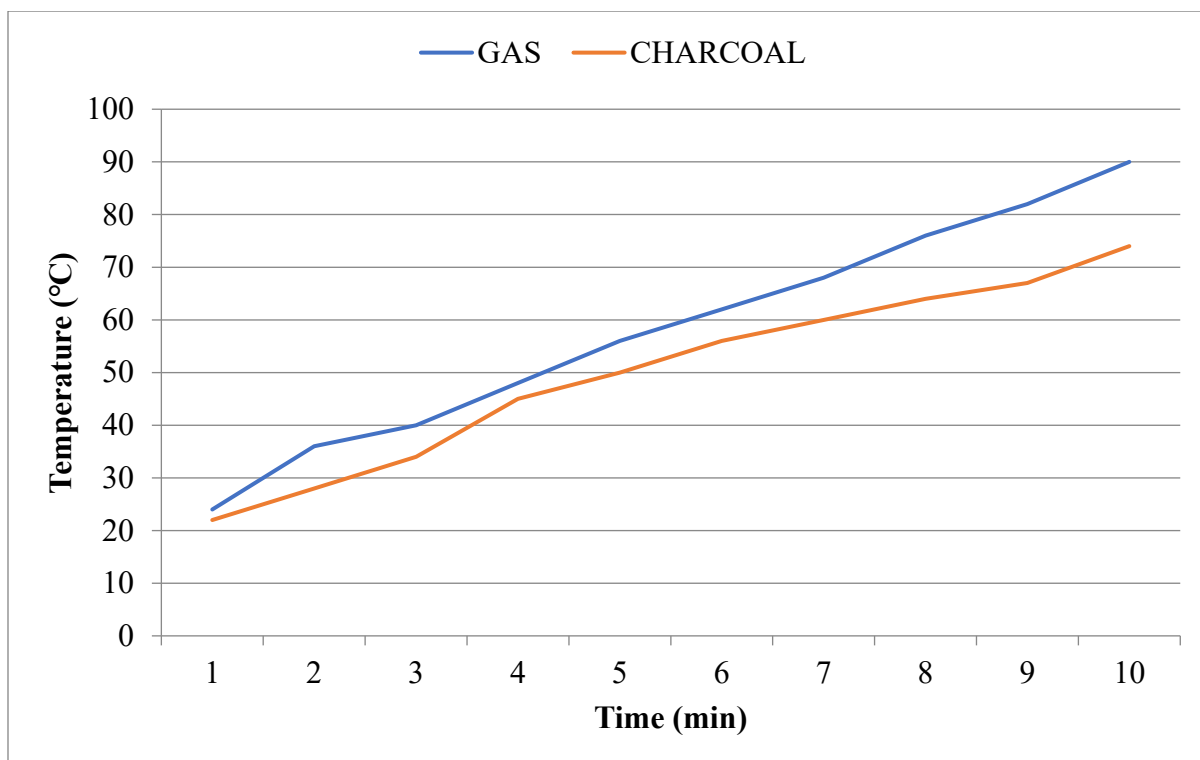
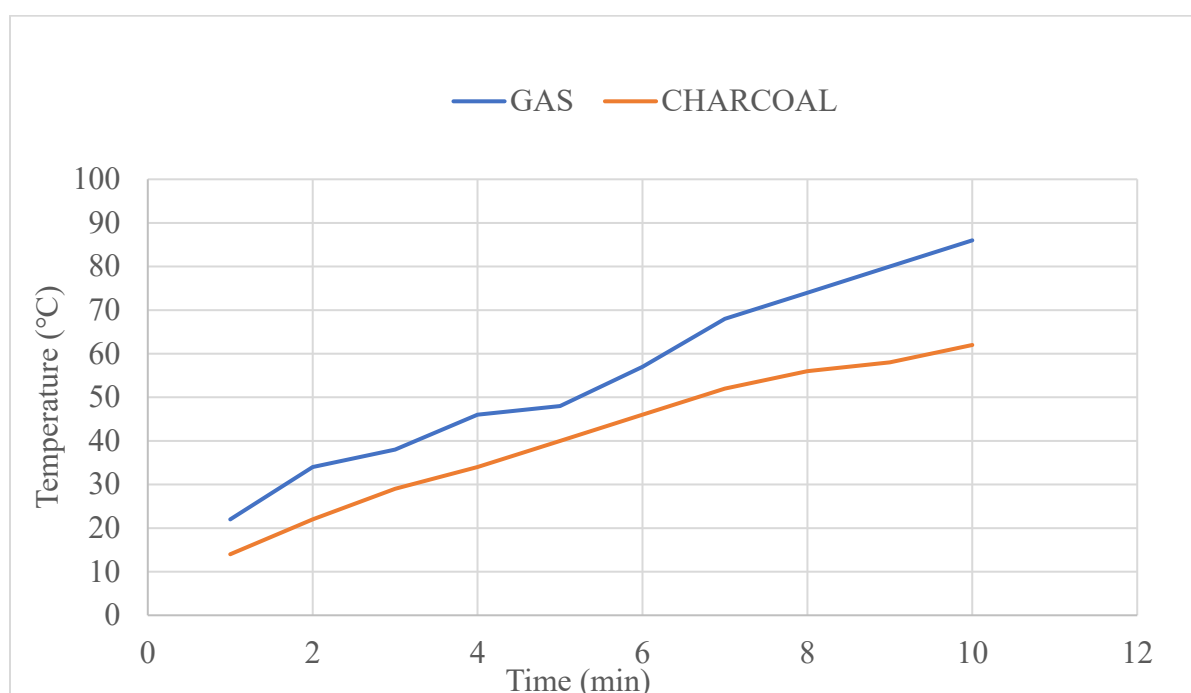

**Figure 4. 7: Comparison for Gas (Max 90°C) and Charcoal (Max 74°C)**

Figure 4.7 shows, the least temperature for gas and charcoal to be 24<sup>0</sup>C and 22<sup>0</sup>C respectively. In two minutes, the temperature recorded for gas was 36<sup>0</sup>C whereas the temperature for charcoal was recorded to be 28<sup>0</sup>C. In three minutes, the temperature for gas was recorded to be 40<sup>0</sup>C whereas that of charcoal was recorded to be 34<sup>0</sup>C. In four minutes, the temperature for gas was recorded to be 48<sup>0</sup>C whereas the temperature for charcoal was recorded to be 45<sup>0</sup>C. In five minutes, the gas recorded its temperature to be 56<sup>0</sup>C whereas charcoal recorded 50<sup>0</sup>C. In six minutes, the temperature for gas and charcoal was recorded to be 62<sup>0</sup>C and 56<sup>0</sup>C respectively. In seven minutes, the temperature for gas and charcoal was recorded to be 68<sup>0</sup>C and 60<sup>0</sup>C respectively. In eight minutes, the temperature for gas was recorded to be 76<sup>0</sup>C whereas that of charcoal was recorded 64<sup>0</sup>C. In nine minutes, the temperature for gas was recorded to be 82<sup>0</sup>C whereas that of charcoal was recorded 67<sup>0</sup>C. In ten minutes, the temperature for gas was recorded 90<sup>0</sup>C whereas that of charcoal was recorded 74<sup>0</sup>C.



#### 4.4.2 Temperature Testing for Gas and Charcoal in Low Cloudy Day



**Figure 4. 8: Comparison for Gas (Max 86°C) and Charcoal (Max 62°C)**

Figure 4.8 represents the temperature threshold for both gas and charcoal. The graph has two columns. The vertical column shows the values for temperature in degree Celsius and the horizontal columns shows the time intervals in minutes. The researcher chose to use two colors to distinguish between the temperature for gas and charcoal. The researcher used red color to represent temperature for charcoal and blue color to represent temperature for gas.

From figure 4.8, in one minute, the researcher recorded the least temperature for gas to be 22°C and 14°C for charcoal respectively. In two minutes, the temperature for gas was recorded to be 34°C whereas that of charcoal was recorded to be 22°C. In three minutes, the gas temperature was recorded to be 38°C whereas that of charcoal was recorded 29°C. In four minutes, the temperature for gas was recorded to be 46°C whereas that of charcoal was recorded to be 34°C. In five minutes, the temperature for gas was recorded to be 48°C and charcoal recorded 40°C. In six minutes, gas and

charcoal temperature was recorded to be 57<sup>0</sup>C and 46<sup>0</sup>C respectively. In seven minutes, gas and charcoal recorded its temperatures to be 68<sup>0</sup>C and 52<sup>0</sup>C temperatures respectively. In eight minutes, gas and charcoal recorded 74<sup>0</sup>C and 56<sup>0</sup>C respectively. In nine minutes, gas and charcoal recorded its temperature to be 80<sup>0</sup>C, 58<sup>0</sup>C respectively. In ten minutes, gas recorded 86<sup>0</sup>C and charcoal recorded 62<sup>0</sup>C.

#### 4.4.3 Temperature Testing for Gas and Charcoal in High Cloudy Day

Figure 4.9 represent the temperature graph for both gas and charcoal. The graph has two columns. The vertical column shows the values for temperature in degree Celsius and the horizontal columns shows the time intervals in minutes. The researcher chose to use two colors to distinguish between the temperature for gas and charcoal. The researcher used red color to represent temperature for charcoal and blue color to represent temperature for gas.

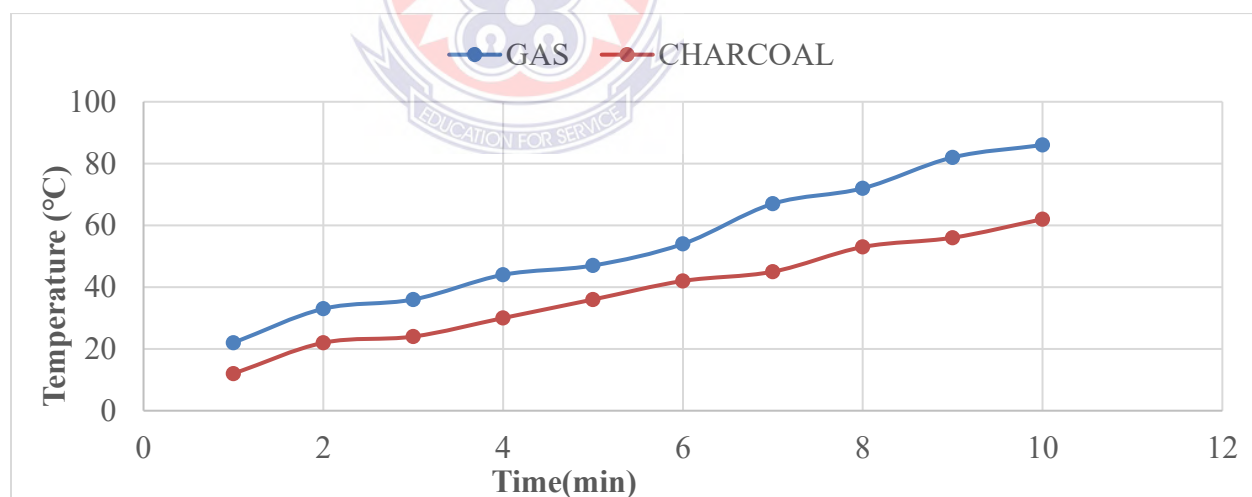

**Figure 4. 9: Comparison for Gas (Max 86<sup>0</sup>C) and Charcoal (Max 62<sup>0</sup>C) in High Cloudy Days**

From figure 4.9 above, in one minute, the researcher recorded the least temperature for gas to be 22<sup>0</sup>C and 12<sup>0</sup>C for charcoal respectively. In two minutes, the temperature

for gas was recorded to be 33<sup>0</sup>C whereas that of charcoal recorded 22<sup>0</sup>C. In three minutes, the temperature for gas was recorded to be 36<sup>0</sup>C whereas that of charcoal was recorded 24<sup>0</sup>C.

In four minutes, the temperature for gas was recorded to be 44<sup>0</sup>C whereas that of charcoal was recorded to be 30<sup>0</sup>C within the same time intervals. In five minutes, gas temperature was recorded to be 47<sup>0</sup>C whereas that of charcoal was recorded to be 36<sup>0</sup>C. In six minutes, the temperature for gas and charcoal was recorded 54<sup>0</sup>C and 42<sup>0</sup>C respectively. In seven minutes, the temperature for gas and charcoal was recorded to be 67<sup>0</sup>C and 45<sup>0</sup>C respectively. In eight minutes, gas and charcoal temperatures were recorded to be 72<sup>0</sup>C and 53<sup>0</sup>C respectively. In nine minutes, gas and charcoal temperatures were recorded to be 82<sup>0</sup>C and 56<sup>0</sup>C respectively. In ten minutes, the temperature for gas was recorded to be 86<sup>0</sup>C and that of charcoal was recorded 62<sup>0</sup>C.

#### **4.5 NO-LOADING (STAGNATION)**

The discussions were focus on three main weather conditions namely; bright day, low cloudy day and highly cloudy day which is further categorized into two main headings: No-loading (without concentrator) and loading (with concentrator) tests respectively.

This experiment was conducted to show that the maximum temperature recorded for No- Loading tests on the bright days, low cloudy days, and highly cloudy days were; 68<sup>0</sup>C, 66<sup>0</sup>C, and 54<sup>0</sup>C respectively on all the three weather conditions on the three separate days with ambient temperature (air temp.) recorded; 67<sup>0</sup>C, 65<sup>0</sup>C, and 54<sup>0</sup>C on the respective days. This means that the temperature recorded on the bright days is the same as on the low cloudy days and vice versa.

The outcome of the tests under **No-Loading** Temperature is as illustrated in figures

4.1, 4.2, and 4.3. The graphs show the variation in the solar radiation and ambient temperature and their effects on the No- Loading Temperature observed on the absorber plate of the solar cooker. The higher average ambient (air temperature) temperature for the test was 62<sup>0</sup>C and that of the absorber plate 62.7<sup>0</sup>C was computed after 152 minutes at 2:32 pm.

#### **4.6 LOADING TEMPERATURE TEST**

The temperature profile on the bright day with the two set-ups namely with and without concentrator as indicated above recorded the maximum temperature between 67<sup>0</sup>C to 72<sup>0</sup>C in the afternoon within a period of 152 minutes.

This shows that the maximum efficiency attained in the afternoon is as shown in the figure 4.1 and 4.4 above from the tables in appendices I & IV. The maximum temperature for bright days was 72<sup>0</sup>C.

The temperature profile on a low cloudy day shows that, the maximum temperature was recorded from 67<sup>0</sup>C to 70<sup>0</sup>C within the same time frame as that of the bright days in the afternoon.

There was no visible increase in temperature which means that the temperature stability of the Solar Box Cooker (SBC) for low cloudy days was slightly less than the bright days as shown in figures 4.2 and 4.5 from the tables in appendices II and V. The maximum temperature recorded for low cloudy days was 70<sup>0</sup>C.

Report from the temperature profile for highly cloudy day depicts that there was very small to gradual shoot-up of temperature readings. The temperature recorded was from 52<sup>0</sup>C to 56<sup>0</sup>C of which the maximum temperature recorded was 56<sup>0</sup>C at noon.

The temperature at highly cloudy days was small as compare to the others because there was small availability of solar radiation; this was also due to cloudy weather

couple with moisture. This is as shown in figure 4.3 and 4.6 from the table in appendices III and VI.

In the experiment two (2), it was observed that when the metallic concentrator was added to the Solar Box Cooker (SBC) there was clear, smooth and constant or stable increase in temperature without temperature rising and falling. This is because the metallic concentrator contributes to the retainability of the infra-red radiation emitted from the sun. The metallic concentrator maximizes the retention and quantum efficiency of the Solar radiation trapped in the SBC.

The Solar Box Cooker (SBC) was constructed and tested with and without a metallic concentrator. The results proved that the metallic concentrator played a major role in intensifying the storing rate of infra-red radiation.

The results were repeated for all the above temperature conditions after including the metallic concentrator. It was observed from the graph that the inclusion of the metallic concentrator maximized the total temperature observed by a stable amount.

The outcome of the tests under **Loading Temperature** is as illustrated in Figures 4.4, 4.5 and 4.6. The graphs show the variation in the solar radiation and ambient temperature and their effects on the Loading Temperature observed on the **absorber plate** of the solar cooker. The higher average ambient (air temperature) temperature for the test was 62<sup>0</sup>C whereas that of absorber plate recorded to be 66<sup>0</sup>C and it was computed after 152 minutes at 2:32pm.

#### **4.7 ANALYSIS OF EFFICIENCY OF THE SOLAR BOX COOKER**

**Efficiency** is the work output over work input times 100% is not a function of the temperature of the absorber plate but a function of the variance in temperature (temperature difference) between the absorber plate temperature and the ambient

temperature (air temp)  $(T_c - T_a)^{\circ}\text{C}$ . The efficiency of the wooden box solar cooker computed was 98.6%. The efficiency is increased with decreased temperature difference between absorber plate temperature and ambient temperature. When temperature is maximized, it does not mean that efficiency is high. Efficiency is reduced with reducing sunlight.

Energy (E) per second ( $\text{Js}^{-1}$ ) radiated by the absorber plate (or collector plate) is based on the collector plate temperature  $(T_c)^{\circ}\text{C}$ . Energy E, is increased as the absorber plate (collector plate) temperature is increased. In the experiment, 15 grammes of yam, 15grammes of rice were allowed to boil using solar box cooker, coal pot, and gas burner. The researcher observed that in the four (4) set ups, gas burner uses 25minutes, charcoal use 55 minutes and solar cooker use 60 minutes for it to be able to cook well using gas, charcoal and infra-red radiation respectively. Solar box cooker uses the highest minutes to cook it food, Coal pot use the next highest minutes to cook it food, and gas burner uses the least time to cook it food.

This shows that solar cooker may not be able to cook fast as compare to the use of gas or charcoal but solar cooker is made very easier way of cooking, safe and simple to work with (it does not pollute the food), and in terms of risk factors it is save to use solar box cooker compare to the other two forms of cooking food.

The use of four (4) reflectors increased the quantity of solar radiation entering the solar box cavity.

The highest temperature of the absorber plate was  $72^{\circ}\text{C}$ . The reflector mirrors assisted to direct more radiation/beam of rays thereby maximized the temperature of the collector plate as indicated in figure 4.4 and 4.5. In the figures 4.1 and 4.2 energy increased as temperature increased. Efficiency increased with decreased difference between absorber plate temperature and ambient temperature  $(T_c - T_a)^{\circ}\text{C}$  as shown in

figures 4.4 and 4.5. Increase in temperature does not necessarily mean an increase in efficiency. Efficiency decreased with decreasing sunlight. The energy and efficiency of Solar Box Cooker were calculated using the equation 1 and 2 in chapter 3.

#### **4.8 ANALYSIS OF HEAT ENERGY REQUIRED FOR CHARCOAL/GAS**

The energy of charcoal was based on the intensity of dryness or loss of moisture in the charcoal, the type of wood, the conductivities in the wood and the atmospheric effect around the set-up. Also, the energy of the gas was based on the volatility and how clean it was affecting the burning rate which increase its temperature. The intensity of gas relating to its burning was high and this speed up its boiling rate as compare to charcoal.

#### **4.9 COMPARISONS BETWEEN SOLAR/SUNLIGHT AND CHARCOAL OR GAS**

The researcher has observed and presented the following benefits of solar cooker which outweighed that of gas or charcoal despite the fact that the boiling rate of solar cooker in certain times of the day is low.

Conventional solar box cookers can attain higher temperatures that can sterilize water and cook most foods that can be made in a solar stove or oven including meat, bread, and vegetables over a period of time as compare to coal pot and gas burners; Solar box cookers use no fuel whereas coal pot, and gas burner use charcoal and gas as fuel; Solar box cooker save cost as well as reducing environmental degradation as compare to fire wood, charcoal, electricity and gas which caused serious damage to our vegetation; Since many people cook on open fires using gas, fire wood, and charcoal as fuels, solar cookers could have large economic and environmental benefits by

reducing land degradation as compare to the common conventional methods use in our homes; The common fire outbreak that comes as a result of live fire from dry wood, gas and charcoal in our market centers destroying many lives and properties running into millions of cedis can be reduced if not completely stop by replacing them with the use of Solar Box Cooker; Since Solar Cookers are being used in an open place, they do not contribute to inside heat as compare to charcoal or gas; Also, Solar cooker saves fuel costs for cooling whereas charcoal or gas does not; Solar cooker does not evaporate oil / grease or other material into the atmosphere, therefore, there may be less clean up as compare to charcoal and gas stoves.





## **CHAPTER FIVE**

### **SUMMARY OF FINDINGS, CONCLUSIONS AND RECOMMENDATIONS**

#### **5.1 INTRODUCTION:**

This is the last chapter of the study and it records the summary, the conclusions made based on the presentations, analysis and the recommendations.

#### **5.2 SUMMARY OF FINDINGS**

Ghana as part of the West Africa subcontinent is blessed with ample amount of sunlight almost all through the year of which the six regions of the North taking the greater percentage of all seasons are sunny, dry and hottest. There is urgent need of switching over to a perennial source of energy reserve as a powerful alternative so as to replace all the fastest depleting fossil fuels. There is much interest in non-conventional energy nowadays so as to tap energy from other sources such as Solar, Wind and Tidal energy of which, tapping the heat and infra-red rays from the sun using air as appropriate medium is the easiest way of collecting solar energy. In order to tap this abundant energy, we require an efficient design of a solar box cooker with a metallic concentrator which heats up the absorber plate and ambient within the fastest possible time. A cost-effective solar box cooker is made with locally available raw materials which are efficient enough to make water reach boiling point and air reach its hottest phase. The researcher conducted a thorough observation within a span of three months working on the solar box cooker with or without the concentrator (cooking vessels painted black at the back) and the detailed records are presented in this piece of work.

The results of the SBC were compared to that of the charcoal and gas temperature test, and it was observed that charcoal and gas temperatures were higher than that of SBC. Hence the boiling rate of the gas was leading followed by that of charcoal and Solar Box Cooker (SBC) was the least. These range of temperatures affected the speed of boiling food for each case. Although, the boiling rate of these methods of cooking food vary from one another for which SBC is the least, it is still much important for one to choose SBC method of cooking food because its merits are far outweighed the conventional methods of cooking food.

### 5.3 CONCLUSION

In conclusion, a wooden box solar cooker was designed, constructed and tested with local available raw materials which is cheap, simple, cost-saving time, and energy.

It has **98.6%** efficiency, and needed **410.849J** of energy for the absorber plate to heat up. The various experiments that were conducted, the maximum temperature **without concentrator** and **with concentrator** recorded for all the three (3) weather conditions are namely: bright day, low cloudy day and high cloudy day recorded: **68<sup>0</sup>C, 66<sup>0</sup>C, 54<sup>0</sup>C** and **67<sup>0</sup>C, 65<sup>0</sup>C, 54<sup>0</sup>C; 72<sup>0</sup>C, 70<sup>0</sup>C, 56<sup>0</sup>C** and **67<sup>0</sup>C, 67<sup>0</sup>C, 52<sup>0</sup>C** for absorber plate and ambient (air) temperature for **set-up 1&2** respectively.

Efficiency was noted to have increased with decreasing temperature differences between absorber plate and ambient (air) temperature ( $T_C - T_a$ ). Increase in temperature does not necessarily lead to increase in efficiency. Efficiency decreased with decreasing solar radiation.

The maximum temperatures and the least energies recorded for charcoal and gas for bright days, low cloudy days and high cloudy days were **74<sup>0</sup>C, 90<sup>0</sup>C** and **1.664KJ, 906.048kJ, 62<sup>0</sup>C, 86<sup>0</sup>C**, and **1.536KJ, 878.592KJ; 62<sup>0</sup>C, 86<sup>0</sup>C** and **1.6KJ, 878.592KJ**

respectively. This means that, for bright day, Solar Box Cooker, charcoal, and gas temperatures values keep on increasing in ascending order of which Solar box cooker recorded the least temperatures and energies followed by charcoal recorded the second highest and gas recorded the most highest temperature value. Low cloudy days and high cloudy days have the same temperature values with slightly different energies for charcoal except the energies for gas in high cloudy days which were recorded the same value. This further suggests that, gas cook food fast followed by charcoal and Solar Box Cooker be the least. The researcher views the numerous available merits of the Solar Box Cooker which outweighed the other two to mean that apart from SBC initial cost in constructions it is best to go in for SBC to supplement our domestic food cooking purposes.

#### **5.4 RECOMMENDATIONS**

This piece of work was based on the research findings, cooking with modified charcoal combined with Solar Box Cookers should be greatly encouraged throughout the country.

The researcher's recommendation was based on the fact that, Solar Box Cooker enhances: saving money, time, energy for girls and woman gathering firewood, it does not pollute or dirty the environment, does not need LPG to power it to function, does not cause environmental degradation, it reduces the risk of snake bite among girls and women when gathering firewood/charcoal and lastly, it has zero-risk factors. This means, it is easy for one to handle/does not easily lead to outbreak of fire that destroys lives and properties as compare to charcoal stoves and gas stoves.

## **5.5 SUGGESTION FOR FURTHER STUDIES**

The author suggested that in the near future, it is possible for one to study this piece of work to see the possible ways one can design and make a preferred solar battery and panel which are peripheral devices that can tap/absorb and stored infra-red radiation made available to be used when there is shortage of energy in the solar box cooker when in used.



## REFERENCES

- A.Claude et al (2012) Archives Applied Science Research 4(4):1636-1649.
- archive.org. (2014) "The solar bowl". archive.org. 22 December 2014. Archived from the original on 22 December 2014.
- Abbas, Q., Khan, A.R., Bashir, A. (2020). "Scaling up renewable energy in Africa: measuring wind energy through econometric approach," Environmental Science and Pollution Research, vol. 27, no. 29, pp. 36282-36294, 2020.
- Acheampong, E. (2010). "Environmental costs of utilizing Ghana's forest for Fuelwood ...", Ghanaweb.com, 2010. [Online]. Available: <https://www.ghanaweb.com/GhanaHomePage/features/Environmental-costs-of-utilizing-Ghana-s-forest-for-Fuel-wood-196516>. (Accessed: 23- Apr- 2019).
- Bowman T.E & Blatt J.H., (1978). 'Solar Cookers, History Design Fabrication Test and Evaluation', First International Symposium of Engineering. Florida, 1978
- Chen et al., (1995) Solar Energy, 54 (4): 227 – 237.
- Cheema L S., (1984). Proc. of National Solar Energy Congress, Vadodara, 1984.
- Chaudhary Q.U.Z. (2009). A procedure to obtain global solar radiation maps from sunshine duration for Pakistan. Solar & wind technology, 7 (2), 245-253.
- Cantina West (2014)."Solar Cookers: Varieties and Styles". Retrieved 4 June 2014.

- CNN. (2007) "Solar lifeline saves Darfur women". CNN. 2007-09 17. Retrieved 2008-03-06.
- Calabrò, E. (2013). "An algorithm to determine the optimum tilt angle of a solar panel from global horizontal solar radiation," *Journal of Renewable Energy*, vol. 2013, Article ID 307547, 12 pages, 2013. View at: [Publisher Site](#) | [Google Scholar](#)
- Felix, A.P, Karl-Heinz, R & Martin, S (2002). Solar thermal system, successful planning and construction, *Solar praxis Berling*, PP.15-17, 101-105.
- Folmer, J.C & Franzen, W (2003): Study of polymer glasses by modulated differential scanning calorimetry, *Stefan Journal of chemical Education* 80 (7) pp.813-818.
- Fincher, Johnathan (2013). "Go Sun: Portable solar oven cooks food in as little as 10minutes". *New Atlas*. September 16, 2013.
- Fahad, S., Wang, J. (2018). "Farmers' risk perception, vulnerability, and adaptation to climate change in rural Pakistan," *Land Use Policy*, vol. 79, pp. 301–309, 2018. View at: [Publisher Site](#) | [Google Scholar](#)
- Garg et al., (1978, 1941-1496) *Proc of International Solar Energy Society Congress, New Delhi, January Vol. 2, 1978, 1941 - 1496.*
- Garg, H. P (1994): Solar cooking technology and promotional programme in India, proceedings of the second world conference on solar cookers use and technology held at Universidad National, Heredia Costa Rica.
- Garba, M.M., & Danmallam, i. m. (2014). Techno-economic and environmental impact analysis of a passive solar cooker for application in

Nigeria, *The International Journal of Engineering And science*, 3, 06-10.

- Ghana Investment Plan. Accra: Ministry of Lands and Natural Resources, 2012.
- Halacy, D. S.; Halacy, Beth (1992). *Cooking with the sun*. La Fayette, CA: Morning Sun Press. pp. 46–47. ISBN 0-9629069-2-1.
- Hafner, M. & Tagliapietra, S. (2020). *The Geopolitics of the Global Energy Transition*, Springer Nature, Basingstoke, UK, 2020.
- Hulio, H. Z. (2021). "Assessment of wind characteristics and wind power potential of gharao, Pakistan," *Journal of Renewable Energy*, vol. 2021, Article ID 8960190, 17 pages, 2021. View at: [Publisher Site](#) | [Google Scholar](#)
- Inhabitat (2014) "World's Largest 38500-meal Solar Kitchen in India". Retrieved 4 June 2014.
- Kiwana, D. (2016) "fuel performance of fiscal sludge briquettes in Kampala, Uganda. Centre for Research in Energy and Energy Conservation". View at: [Google Scholar](#).
- Katiyar, A. & Pandey. (2013). "A review of solar radiation models—part I," *Journal of Renewable Energy*, vol. 2013, Article ID 168048, 11 pages, 2013. View at: [Publisher Site](#) | [Google Scholar](#)
- Kwakwa, Paul, Wiafe, Edward & Alhassan, Hamdiyah. (2013). *Households Energy Choice in Ghana*. *Journal of Empirical Economics*. 1. 96-103.
- Mae, D. & Matlock, I. (2013). *Solar Cookers Revolutionize West Africa Events*.

Technology, Computer and Gadgets. Retrieved from

<http://www.ghanaschoolsnet.com/forum/topics/solar-cookers-revolutionize-west-africa-events>. Accessed: January, 23, 2020.

- Melanic, S (2006). Field test of the hot pot, a new solar cooker in West Africa, solar household energy Incorporated. Solar cooking for Human Development and Environment Relief.
- Mussard, M., Gueno, A. & Nydal, O. J. (2013). Experimental study of solar cooking using heat storage in comparison with direct heating. *Solar Energy*, 98, 375.
- Makenzi, M., Muguthu, J. & Murimi, E. (2020). “Maximization of site specific solar photovoltaic energy generation through tilt angle and sun-hours optimization,” *Journal of Renewable Energy*, vol. 2020, Article ID 8893891, 11 pages, 2020. View at: [Publisher Site](#) | [Google Scholar](#)
- Nicholas, C. Alan. THE TRACKING SOLAR COOKER. [solarcooking.org](http://solarcooking.org)
- Nayak, N., Abu Jarir, H., & Al Ghassani, H. (2016). “Solar cooker study under Oman conditions for late evening cooking using stearic acid and acetanilide as PCM materials,” *Journal of Solar Energy Engineering*, vol. 2016, Article ID 2305875, 6 pages, 2016. View at: [Publisher Site](#) | [Google Scholar](#)
- Okino, J., Komakech, A. J., Wanyama, J. Ssegane, H., Olomo, E. & Omara, T. (2021). “Performance characteristics of a cooking stove improved with sawdust as an insulation material,” *Journal of Renewable Energy*, vol. 2021, Article ID 9969806, 12 pages, 2021. View at: [Publisher Site](#) | [Google Scholar](#)
- Prinsloo, GJ & Dobson, RT (2015). "Solar Tracking": doi:10.13140/RG.2.1.265.6329/1. ISBN 978-0-620-61576-1.
- Park, S.R., Pandey, A. K., Tyagi, V.V., & Tyagi, S. K. (2014). *Energy*



and exergy analysis of typical renewable energy systems. *Renewable and Sustainable Energy Reviews*, 30, 105

- Ruiz-Mercado, I., Canuz, E., Walker, J. L. & Smith, K. R. (2013). Quantitative metrics of stove adoption using Stove Use Monitors (SUMs). *Biomass and Bioenergy*, pp. 136-148.
- Ronge, H., Niture, V. & Ghodake, D.S. (2016). A Review Paper on Utilization of Solar Energy for Cooking. *Imperial International Journal of Eco-friendly Technologies*, 1(1), 121 – 124.
- Ramesh, et al (2018). Performance Evaluation and Cost Economics of Developed Box Type solar cooker. *Int.J. Curr. Microbiol.APP.SCI*.7 (12):1788-1795.

doi: <https://doi.org/10.20546/ijcmas.2018.712.208>.

- Ramanathan, et al. (2020). “Climate change, air pollution, and health: common sources, similar impacts, and common solutions,” in *Health of People, Health of Planet and Our Responsibility: Climate Change, Air Pollution and Health*, W. K. Al Delaimy, V. Ramanathan, and M. Sánchez Sorondo, Eds., pp. 49–59, Springer International Publishing, Cham, Germany, 2020. View at: [Publisher Site](#) | [Google Scholar](#)
- Smith, K., Mehta, S. & Maeusezahl-Feuz, M. (2004). Indoor smoke from household solid fuels. In: M. Ezzati, A. D. Rodgers, A. D. Lopez & C. J. L. Murray, eds. *Comparative Quantification of Health Risks: Global and Regional Burden of Disease due to Selected Major Risk Factors*. Geneva: World Health Organization, p. 1435–93.

- Solar cooker pictures Solar Cooking Atlas official website
- Shah, Yatish T. (2018). Thermal Energy: Sources, Recovery, and Applications. CRC Press.12 January,2018 pp. 340–. ISBN 978-1-315 30593-6.
- See Parabola#Focal length and radius of curvature at the vertex.
- Singh, C. S. (2009). Renewable Energy Technologies. A practical guide to beginners. PHI Learning private Limited, New Delhi, pp.60-68.
- Shahbaz, M., Chaudhary A. R, & Ozturk, I. (2017). “Does urbanization cause increasing energy demand in empirical evidence from STIRPAT model,” Energy, vol. 122, pp. 83–93, 2017. View at: Publisher Site | Google Scholar
- Twmffat, Tecwyn.(2016) "Solar cooked mackerel on the rocks". instructables.com. Retrieved September 26, 2016.
- The Tiny Life (2018)"The Complete Solar Oven Guide: 6 Best Solar Oven Reviews | The Tiny Life". The Tiny Life. Retrieved 2018-08-11.
- Thirugnanam,C. Karthikeyan, S.& Kalaimurugan, K. (2020). “Study of phase change materials and its application in solar cooker,” Materials Today: Proceedings, vol. 33, pp. 2890–2896, 2020. View at: Publisher Site | Google Scholar
- UANews (2013)"Solar Oven Throwdown Heats Up UA Mall". UANews. October 23, 2013.
- "WHO (2014): Household Air Pollution and Health". World Health Organization. Retrieved 15 May 2014.
- Yaffe, Linda Frederick (2007). Solar Cooking for Home and Camp. Mechanicsburg,PA: Stackpole Books. pp. 16–20. ISBN 0-8117-3402-1.

## APPENDICES

### APPENDIX I: No-Loading Temperature Test (Without Concentrator)

**Table 4. 1: Bright Day/Sun Light**

TIME (min)	TEMPERATURE (DEGREE CELSIUS, °C)	
	ABSORBER PLATE	AMBIENT
-		
1	22	24
2	38	40
3	42	42
4	54	55
5	56	60
6	68	67
7	54	53
8	46	45
9	40	42
10	36	35
<b>TOTAL</b>	<b>456</b>	<b>463</b>

**APPENDIX II****Table 4. 2: Low Cloudy Day**

<b>TIME (min)</b>	<b>TEMPERATURE (DEGREE CELSIUS, °C)</b>	
	<b>ABSORBER PLATE</b>	<b>AMBIENT</b>
1	20	20
2	36	38
3	42	44
4	50	53
5	55	55
6	66	65
7	54	55
8	45	46
9	44	44
10	32	32
<b>TOTAL</b>	<b>444</b>	<b>452</b>

**APPENDIX III****Table 4. 3: Highly Cloudy Day**

<b>TIME (min)</b>	<b>TEMPERATURE (DEGREE CELSIUS, °C)</b>	
	<b>ABSORBER PLATE</b>	<b>AMBIENT</b>
1	12	12
2	20	22
3	32	34
4	38	38
5	42	44
6	48	48
7	54	54
8	50	52
9	46	46
10	42	42
<b>TOTAL</b>	<b>384</b>	<b>392</b>

**APPENDIX IV: Loading Temperature Test (With Concentrator)****Table 4. 4: Bright Day/Sun Light**

TIME (min)	TEMPERATURE (DEGREE CELSIUS, °C)	
	ABSORBER PLATE	AMBIENT
1	22	24
2	38	40
3	44	42
4	56	54
5	62	60
6	72	67
7	64	53
8	60	45
9	54	42
10	42	35
<b>TOTAL</b>	<b>514</b>	<b>463</b>

## APPENDIX V

Table 4. 5: Low Cloudy Day

TIME (min)	TEMPERATURE (DEGREE CELSIUS, <sup>0</sup> C)	
	ABSORBER PLATE	AMBIENT
1	22	24
2	36	40
3	44	42
4	54	53
5	62	66
6	70	67
7	63	53
8	60	45
9	54	42
10	40	36
<b>TOTAL</b>	<b>505</b>	<b>469</b>

**APPENDIX VI****Table 4. 6: Highly Cloudy Day**

<b>TIME (min)</b>	<b>TEMPERATURE (DEGREE CELSIUS,<sup>0</sup>C)</b>	
	<b>ABSORBER PLATE</b>	<b>AMBIENT</b>
1	12	12
2	20	18
3	32	31
4	36	33
5	42	40
6	48	46
7	56	52
8	52	50
9	48	44
10	44	42
<b>TOTAL</b>	<b>390</b>	<b>370</b>



**APPENDIX VII****Table 4. 7: Temperature Testing for Gas and Charcoal**

<b>TIME (min)</b>	<b>TEMPERATURE (°C)</b>	
	<b>GAS</b>	<b>CHARCOAL</b>
1	24	22
2	36	28
3	40	34
4	48	45
5	56	50
6	62	56
7	68	60
8	76	64
9	82	67
10	90	74
<b>TOTAL</b>	<b>582</b>	<b>500</b>

## APPENDIX VIII

Table 4. 8: Temperature Testing for Gas and Charcoal in Low Cloudy Day

TIME (min)	TEMPERATURE (°C)	
	GAS	CHARCOAL
1	22	14
2	34	22
3	38	29
4	46	34
5	48	40
6	57	46
7	68	52
8	74	56
9	80	58
10	86	62
<b>TOTAL</b>	<b>553</b>	<b>413</b>



## APPENDIX IX

Table 4. 9: Temperature Testing for Gas and Charcoal in High Cloudy Day

TIME (min)	TEMPERATURE (°C)	
	GAS	CHARCOAL
1	22	12
2	33	22
3	36	24
4	44	30
5	47	36
6	54	42
7	67	45
8	72	53
9	82	56
10	86	62
<b>TOTAL</b>	<b>543</b>	<b>382</b>

## APPENDIX IIX

### BREAKDOWN OF EXPENSES ON SOLAR COOKER

Wood (plywood) = 130

Glass (transparent glass lid) = 54

Reflector (mirror) = 72

Absorber plate = 40

Cooking pot = 45

Black paint = 60

White paint = 60

Nails = 10

Insulator (Foam) = 72

Glue (3 supper 99) = 24

Thermometer (100<sup>0</sup>C) = 90

Brush = 5

hinges (8) = 6.4

Screw nails = 7

white glue = 20

Tools rentals = 290

Copper wire = 20

Claw hammer = 12

White glue = 6

Petrol = 7

Charcoal = 45

Gas = 60

TOTAL: GHC 1135.40

