

**UNIVERSITY OF EDUCATION, WINNEBA**

**MODIFICATION AND CONSTRUCTION OF A CASSAVA DOUGH SINGLE  
SCREW PRESS MACHINE**



**MR. PATRICK PRAH**

**2021**

**UNIVERSITY OF EDUCATION, WINNEBA**

**MODIFICATION AND CONSTRUCTION OF A CASSAVA DOUGH SINGLE  
SCREW PRESS MACHINE**

**BY**

**MR. PATRICK PRAH**

**(1081547)**

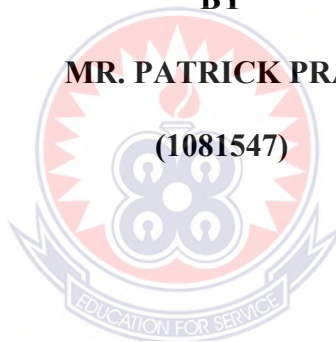

**A dissertation in the department of MECHANICAL AND AUTOMOTIVE  
TECHNOLOGY EDUCATION, faculty of TECHNICAL EDUCATION,  
submitted to the School of Graduate Studies in partial fulfillment of the  
requirements for the award of the degree of Master of Technology (Automotive  
Engineering) in the University of Education, Winneba**

**DECEMBER, 2021**

## DECLARATION

In presenting this work, I hereby declare that this is the accurate account of the undersigned student own work for the purpose of a Master of Technology in Automotive Engineering under the supervision of Mr. C.K Nworu from other people's work which has been properly acknowledge.

Student: ..... Signature: .....

Applicant Number: ..... Date: .....



.....  
Supervisor's Name

.....  
Signature

Date: .....

## ACKNOWLEDGEMENT

My sincere appreciation goes to the dissertation supervisor, Mr. C.K Nworu for his support and paternal role played in the work.

Again, I will like to thank the Mechanical Workshop personnel of the University of Cape Coast by rendering unto me the opportunity of getting access to the lab to perform this dissertation.

Finally, I acknowledge all the lectures in the Mechanical and Automotive Engineering Education Department of Akenten Appiah-Menka University of Skills Training and Entrepreneurial Development.



## TABLE OF CONTENTS

<b>Content</b>	<b>Page</b>
DECLARATION	ii
ACKNOWLEDGEMENT	iii
TABLE OF CONTENTS	iv
LIST OF TABLES	viii
LIST OF FIGURES	ix
ABSTRACT	x
<b>CHAPTER ONE: INTRODUCTION</b>	
1.1 Background to the Study	1
1.2 Statement of the Problem	2
1.3 Aim and Objectives	3
1.3.1 Aim	3
1.3.2 Objective	3
1.4 Design Questions	3
1.5 Scope of Study	4
1.6 Limitation	4
<b>CHAPTER TWO: LITERATURE REVIEW</b>	
2.1 Introduction	5
2.2 Cassava	5
2.3 Cassava Processing Steps	6
2.4 Traditional Methods of Grating Cassava	8
2.5 Manually Operated Cassava Graters	8
2.5.1 Hand Operated Cassava Grating Machines	9



2.5.2 Pedal Operated Cassava Grating Machines	10
2.6 Engine Powered Cassava Grating Machines	11
2.7 Electricity Powered Cassava Grating Machines	12
2.8 Overview of A Press Machine	17
2.9 Equipment and Material Often Used in Designing the Pressing Machine	18
2.10 The Role of Cassava Products	20
2.11 Literature Summary	22
 <b>CHAPTER THREE: MATERIALS AND METHOD</b>	
3.1 Design Consideration	23
3.2 Two Conceptual Designs	23
3.2.1 Conceptual Design One	24
3.2.1.1 Exploded View for Design One	25
3.2.2 Conceptual Design Two	26
3.3 Annotated Design for Cassava Dough Single Screw Press	31
3.4 Materials Selection Used in the Construction	31
3.4.1 Description of Machine Parts	32
3.5 Design Process	33
3.5.1 Circumstances	33
3.5.2 Brief	34
3.5.3 Analysis	34
3.5.4 Investigation	35
3.5.5 Specification	35
3.5.5.1 The Function	35
3.5.5.2 Material	35
3.5.5.3 Ergonomic	36

3.5.5.4 Aesthetics	36
3.5.5.5 Cost	37
3.6 Methodology	37
3.6.1 Machineries and Machining Processes Used In The Fabrication Processes	37
3.6.2 Other Tools Used for The Fabrication of The Object	38
3.6.3 Safety Gears and Safety Precautions	39
3.6.4 Safety Precautions	39
3.6.5 Machining Operations	40
3.7 Construction	40
3.8 Safety	41
3.9 Finish	41
3.10 Operational Sequence for the Two Designs	42
<b>CHAPTER FOUR: DESIGN CALCULATIONS</b>	
4.1 The Volume and The Surface Area of Inner Perforated Cylinder	43
4.2 The Volume and The Surface Area of an Outer Cylinder	44
4.3 Production Cost Analysis	46
4.4 Precautions and Maintenance	47
4.4.1 Precautions	47
4.4.2 Maintenance	47
4.5 Method of Testing and Results	48
<b>CHAPTER FIVE: SUMMARY, CONCLUSION AND RECOMMENDATION</b>	
5.1 Summary	51
5.2 Conclusion	52
5.3 Recommendations	52

REFERENCES	53
APPENDIX	54





## LIST OF TABLES

<b>Table</b>	<b>Page</b>
1. Parts of the Object	26
2. Comparison of Conceptual Designs	27
3. Parts of the Object	27
4. Materials Used For The Construction	31
5. Job Cost for Construction of Cassava Dough Single Screw Pressing Machine	46



## LIST OF FIGURES

<b>Figure</b>	<b>Page</b>
1. Dorisj/Getty Images	6
2. Peeling of cassava by women at Bawjoase in the Central Region, Ghana	7
3. A Hand Grater (Opandoh, 2015)	8
4. The constructed hand operated manual cassava grater (Apodi et al., 2018)	9
5. A Dual - Operational Cassava Grating Machine (Ndaliman, 2006)	10
6. Pedal operated cassava grater (a) Isometric view (b) Picture after construction (Yusuf et al, 2019)	11
7. Isometric drawing of Mobile cassava grater	12
8. Improved cassava grater (a) isometric view (b) front view	13
9. Heavy stone on top of mash sack	14
9.1 Hanging	14
10. Screw Method	17
11. Jack methods (Diop, 1998).	17
12. Cassava Pulp Dewatering Machine. Source: <a href="http://www.unilorin.edu.ng">www.unilorin.edu.ng</a>	20
13. Hydraulic Press	21
14. Single Screw Press	21
15. Double Screw Type	22
16. Conceptual Design One (1)	24
17. Conceptual Design One - Exploded View	25
18. Conceptual Design Two (2)	26

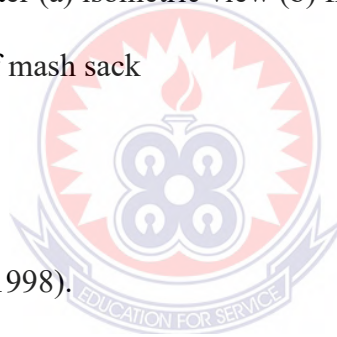

## ABSTRACT

The new method of extracting juice from cassava dough for gari processing is done by the use of cassava dough single screw pressed machine. The concept of this was first introduced to Asia in the 17<sup>th</sup> century and to Africa in about 1558 according to Quadri A.H (2010). However, despite the importance of this technology a number of deficiencies could be found using the machine. This dissertation is focused on modification and construction of the existing cassava dough screw pressing machine which would be useful for home-use, retailers and small-scale farmers and also to promote healthy consumption of cassava products. Some design considerations used in this dissertation include; the efficiency of the machine during usage in the household; the portability of the machine among others. Another problem considered in this construction was the fact that cassava produces a large amount of cyanogenic glycosides, so in selecting materials for construction, adequate care was taken not to use materials that cannot degrade/ corrode easily due to the acidic content in cassava. The volume and the surface area of the perforated cylinders were  $0.024\text{m}^3$  and  $0.47\text{m}^2$  respectively. Also, the outer cylinder has a volume and surface area of  $0.031\text{m}^3$  and  $0.549\text{m}^2$  respectively. The inner cylinder has been modified with the use of stainless steel whereas the outer cylinder and bevel gears used are the new invention made. The object or machine runs by man power. It is recommended that the efficiency and the speed at which the machine operates can further be improved. This could be done by weight reduction and the reduction of vibration.

## CHAPTER ONE

### INTRODUCTION

#### 1.1 Background to the Study

According to Quadri (2010), cassava originated from Latin America and was later introduced to Asia in the 17<sup>th</sup> Century and to Africa in about 1558. Cassava is an important food security and income generation crop for households in many countries of Sub-Saharan Africa. The tubers of cassava cannot be stored for too long. Processing follows immediately into flour and Gari. In Ghana, cassava is mostly grown on large and small farms and even on backyard gardens.

Cassava tubers may considerably vary in size from 15 to 100 cm as well as in terms of weight from 0.5 to 2.0 kg (Westby, 2009). Cassava contributes significantly (22%) to the Agricultural Gross Domestic Product (AGDP) (Nweke, 2005). It is very rich in starch, and contain significant amounts of calcium (50 mg/100g), phosphorus (40 mg/100g), vitamin C (25 mg/100g), and relatively good quality of protein (Kolawole, Agbetoye, & Ogunlowo, 2010). Gari, Tapioca (starch) and Agbelima (fermented cassava mash), are among other numerous staple foods in Africa especially in Nigeria and Ghana that are products of cassava (Kleih, Phillips, Wordey, & Komlaga, 2013). The vast economic and health benefits of cassava led to a steady increase in its production in Ghana. From the year 2000 to 2010, the annual production in Ghana increased progressively from 8,107,000 Mt to 13,504,000 Mt (Nimoh, Asare, Twumasi, & Anaman, 2018). The increasing production level of the commodity makes it necessary to mechanize its processing. The stages in cassava processing includes either one or more of the following; peeling, washing, grating or chipping, pressing (de-watering), pulverization, sieving, roasting and milling, depending on the type of end product required (Richard Bayitse, Ferdinand Tornyie, 2019)

Pressing the cassava with a screw press, similar to the existing system, would be another option to remove the juice from the cassava dough similar. This process would place ground cassava into burlap sacks, and then place the sacks into the press. The press would then be used to squeeze out the juice which would be collected.

The current process requires that the cassava be left in the screw press over night to remove the necessary amount of moisture.

## **1.2 Statement of the Problem**

Presently in Ghana, the products of cassava are usually locally consumed and exportation is limited because the products do not always meet the international standards for healthy foods. Thus, the need to encourage the use of small-scale production of cassava products to ensure quality of products and good hygienic values (reduce foreign body and sand content in products); thereby protecting the health of basic building element of our nation.

Preliminary interview conducted by the researcher at Abuenu in Abura Asaebu Kwaman Kese Municipality, revealed that most small-scale farmers, house-wives and retailers usually have to travel long distances with fresh cassava tubers for grating and dewatering to reduce the cost of cassava processing.

(QUADRI, 2010) study revealed that most of the cassava screw presses are usually corroding (reducing service life) due to the acidic nature of the cassava fluid and materials used for the fabrications. However, to ensure that all cassava products are free from any taste, odour, or infected by iron content of parts (food poisoning) which may affect the quality of their contents there is need to modify the existing design and also consider more hygienic food processing materials for the fabrication. One major problem with the traditional processing method is that the product tuber spoils after 2-

3 days of harvesting. This is an indication that there is the need to process into safer stable products.

The introduction of this machine will reduce a problem of using hand or tied stick technique (usual method) for extracting cassava dough from the juice and also reduce the number of the skilled labor that lead to high rate of production (QUADRI, 2010).

Unhygienic way of putting the dough on block or sometime on the bare floor for dewatering will also be a thing of the past if the new method is adopted.

In view of the above-mentioned problems and looking at the economics importance of the cassava products; modification design of the existing cassava dough screw press, is necessary to address the problems of cassava processing.

### **1.3 Aim and Objectives**

#### **1.3.1 Aim**

The aim is to modify the design of an existing cassava dough single screw press machine to a home use-small scale sizes.

#### **1.3.2 Objective**

Objective of the study are to:

1. Modify the design of an existing cassava dough single screw press machine.
2. Construct the modified cassava dough screw press machine. and
3. Evaluate the performance of the modified single screw press machine in terms of time saving, cost, efficiency and hygienic nature of the cassava dough.

### **1.4 Design Questions**

1. Are the materials used for construction going to make the products healthy or safe?
2. Under which circumstance is the machine going to save time and cost?

### **1.5 Scope of Study**

The scope of the study is to modify the design of a hand cassava dough screw press machine which would be useful for home-use, retailers and small scale farmers. To select suitable materials based on result of the analysis for the fabrication of the machine; and to prepare a neat and detailed working drawing for the construction process; and discuss the results of the performance test.

### **1.6 Limitation**

The efficiency of the developed cassava dough single screw press machine will be compared to the traditional method of dewatering cassava dough only due to insufficiency of funds. However, there could be useful findings if it were compared to other manually operated screw press and even motorized pressing.



## CHAPTER TWO

### LITERATURE REVIEW

#### 2.1 Introduction

This chapter deals with the related literature about the modification and construction of a cassava dough screw press machine. This chapter further review the steps involved in cassava processing and previous efforts made in the development of cassava dough machines. It specifically looks at the traditional methods and the type of cassava dough machines currently in the system.

#### 2.2 Cassava

Cassava is a vegetable that is a staple ingredient of many diets worldwide. It is a good source of nutrients, but people should avoid eating it raw. Raw cassava contains cyanide, which is toxic to ingest, so it is vital to prepare it correctly. Also, there are two types of cassava: sweet and bitter. Bitter cassava is hardier but has much higher cyanide content. Most of the cassava used in the United States is sweet.

In the U.S., people grind cassava down to make tapioca, which they eat as a pudding or use as a thickening agent.

In this article, we provide an overview of cassava and its benefits and risks. We also suggest ways to prepare it. Medically reviewed by (Warwick and Dresden, 2021)





### **Figure 1: Fresh cassava (Dorisj and Getty, 2011)**

Cassava is a root vegetable. It is the underground part of the cassava shrub, which has the Latin name *Manihotesculenta*. Like potatoes and yams, it is a tuber crop. Cassava roots have a similar shape to sweet potatoes (Warwick and Dresden 2021).

People can also eat the leaves of the cassava plant. Humans living along the banks of the Amazon River in South America grew and consumed cassava hundreds of years before Christopher Columbus first voyaged there.

Today, more than 80 countries throughout the tropics grow cassava, and it is a primary component of the diet of more than 800 million people around the world.

It is popular because it is a hardy crop that is resistant to drought and does not require much fertilizer. That said, it is vulnerable to bacterial and viral diseases.

Cassava is a versatile, flavorful food and an important source of nutrients and energy, particularly in the tropics.

Cassava is similar to yams and taro, and people can use it in similar ways to a potato.

It is possible to use tapioca starch to make gluten-free baked goods. As long as people take precautions when preparing cassava, it can be a beneficial addition to the diet.

Scientists are currently mapping the genetic structure of cassava. They hope to be able to use this information to breed superior cassava plants that will have higher nutritional content, be more resistant to disease, and make it to market more easily.

### **2.3 Cassava Processing Steps**

The most common steps used in processing cassava into desired products usually include peeling and washing, grating or chipping, and then dewatering or pressing (Richard Bayitse, Ferdinand Tornyie, 2019). After fresh cassava is harvested from the

farm, simple knives or machete are used to remove the outer layer of the cassava which is usually brown in colour (Figure 2.1).

The covers are by-products used as animal feed. The peeled cassava is then washed and cut into smaller units ready for grating or chipping. If the intended product is gari, the cassava is grated into fine mash, dewatered or pressed, allowed to ferment for about 2 to 3 days, sifted to crush the lumps caused by the pressing, and then roasted or fried into gari. If the needed product is agblema, the cassava is grated into fine mash, dewatered and allowed to ferment for about 2 to 3 days, sieved and boiled in banana leaves. If the needed product is flour, the cassava is chipped into smaller pieces which enable it to dry faster, milled into flour (Zvinavashe, Elbersen, Slingerland, Koliijn, & Sanders, 2011).



**Figure 2: Peeling of cassava by women at Bawjoase in the Central Region, Ghana (Bayitse, Tornye and Bjerre, 2017)**

## 2.4 Traditional Methods of Grating Cassava

In the old days, mortar and pestle were the tools used for producing cassava mash. Pounding was the only available method of processing peeled cassava into the desired grade of cassava mash, until artisans later on developed the hand grater. This consists of a thin metal sheet perforated with about 3mm diameter nail to produce sharp projections on one surface. the plate is then nailed to a piece of wood with the rough surface outwards. During grating, peeled cassava tuber is rubbed against the rough plate surface by hand to produce cassava mash.(George, 2018). This gives better results than the pounding, especially when granules are required. However, it is steel fatiguing and risky since the hand of the user could be injured by the grating plate when the cassava tuber reduces to a smaller piece (Opandoh, 2015).

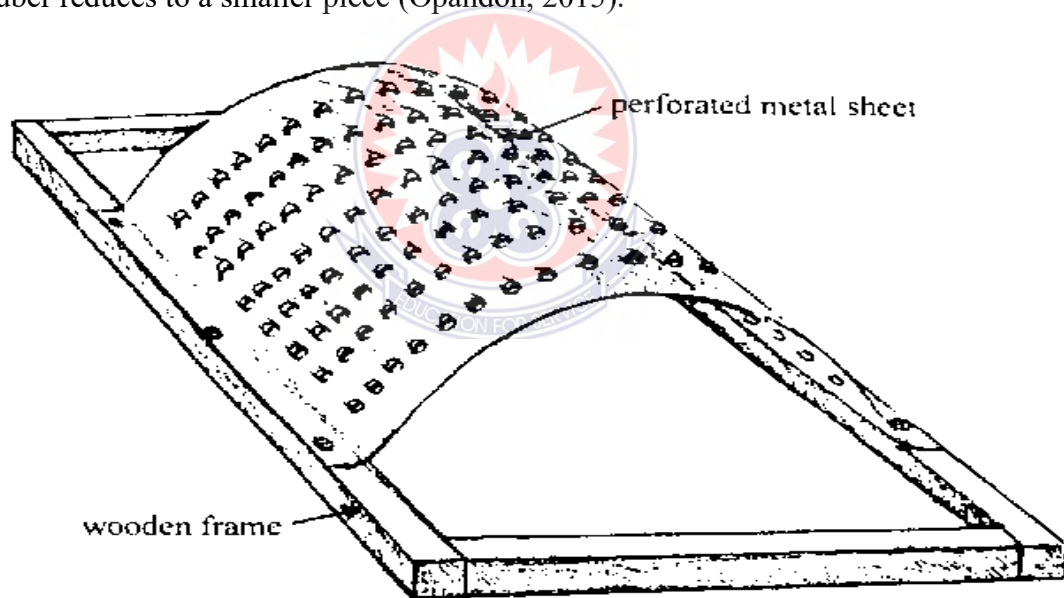

Figure 3:A Hand Grater (Opandoh, 2015)

## 2.5 Manually Operated Cassava Graters

Manually operated cassava graters are mechanical cassava graters with their source of drive being their operators. They can be put into two groups namely; hand operated and pedal operated cassava grating machines. In both cases no engine or electric motor is used.

### 2.5.1 Hand Operated Cassava Grating Machines

This is a category of manually operated cassava graters in which the grating drum is rotated through a crank turned by the operator's hand. Apodi et al., (2018) designed and manufactured a hand operated cassava grater operated by two hands. Peeled and washed cassava is cut into smaller pieces and fed into the hopper. One hand uses a presser to force the cassava against the grating drum while the other hand turns the crank to rotate the grating drum. Its capacity was about 314 kg/h since it grated 78.5kg of cassava within 15 minutes. It recorded 5.5% waste with 94.5% efficiency. Figure 3 shows a picture of the constructed hand operated manual cassava grater.



**Figure 4: The constructed hand operated manual cassava grater (Apodi et al., 2018)**

Ndaliman, (2006) designed and constructed a portable hand operated cassava grating machine. He however made provision for the use of an electric motor when the need arises. Its operation involves feeding peeled and washed cassava into the metal hopper and pressing the cassava against the rotating drum with a piece of wood. In this design,

the grating drum is either rotated by hand crank or an electric motor through pulley and belt drive. The efficiency of the machine when operated manually with hand was found to be 92.4%. It was tested with only 2.0 kg of cassava which is willfully inadequate to give a true picture of its grating capacity and efficiency. The grating capacity, a very important parameter, was however omitted. Figure 3 shows a picture of the constructed dual operational mode cassava grating machine.



**Figure 5: A Dual - Operational Cassava Grating Machine (Ndaliman, 2006)**

### **2.5.2 Pedal Operated Cassava Grating Machines**

This is a category of manually operated cassava graters in which the grating drum is rotated by a chain and sprocket driven through foot pedaling of two cranks. Yusuf et al., (2019) designed and fabricated a pedal operated cassava grating machine with the stand and hopper made of hard wood. Peeled cassava is washed, cut into smaller pieces and fed into the wooden hopper. The operator then sits on a seat and pedal the pair of cranks that cause the rotation of the grating drum through the chain and sprocket drive. It had grating capacity of 102.9 kg/h and efficiency of 90.91%. Though the capacity and



efficiency of this pedal operated grater are lesser than that of the hand operated grater by Apodi et al., (2018), the pedal operation is more comfortable than the hand operated. However, if pair of handles for the operator was included it would have made it more convenient to operate, which could lead to an increase in its grating capacity and efficiency. Figure 4 presents a picture of the pedal operated cassava grater.

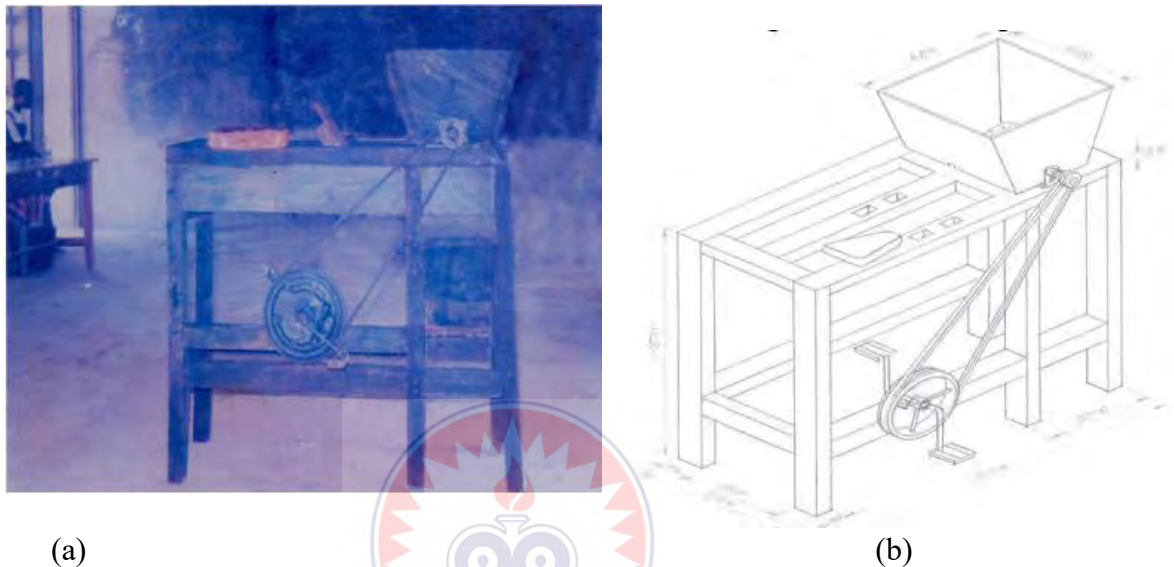
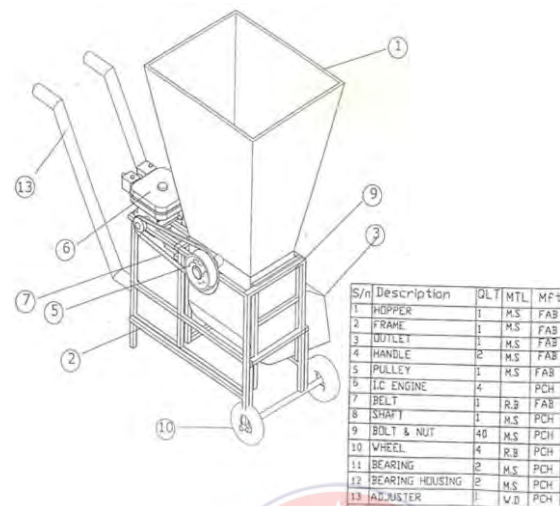

**Figure 6: Pedal operated cassava grater (b) Isometric view (a) Picture after construction (Yusuf et al, 2019)**

## 2.6 Engine Powered Cassava Grating Machines

Some cassava graters are powered by internal combustion (IC) engines running either on petrol or diesel. Engines are used when higher grating capacities are required in areas without electricity or when a mobile cassava grater is required for grating cassava at different locations. Aideloje, Okwudibe, Jimoh, and Olawepo, (2018) developed, fabricated and tested a mobile cassava grating machine with a petrol engine as the prime mover. The grating capacity is 55.79 kg/h and its production cost is ₦42,000.00. The main parts of the machine are the frame, hopper unit, grating drum, delivery channel and ground wheels. It also has a pair of handles for pushing the purpose. The mode of operation involves starting the engine, allowing it to stabilize and then feeding peeled

cassava into the hopper. The rotation of the grating drum grates the cassava into mash which is collected through the delivery channel. Figure 5 shows the isometric drawing of the mobile cassava grater.

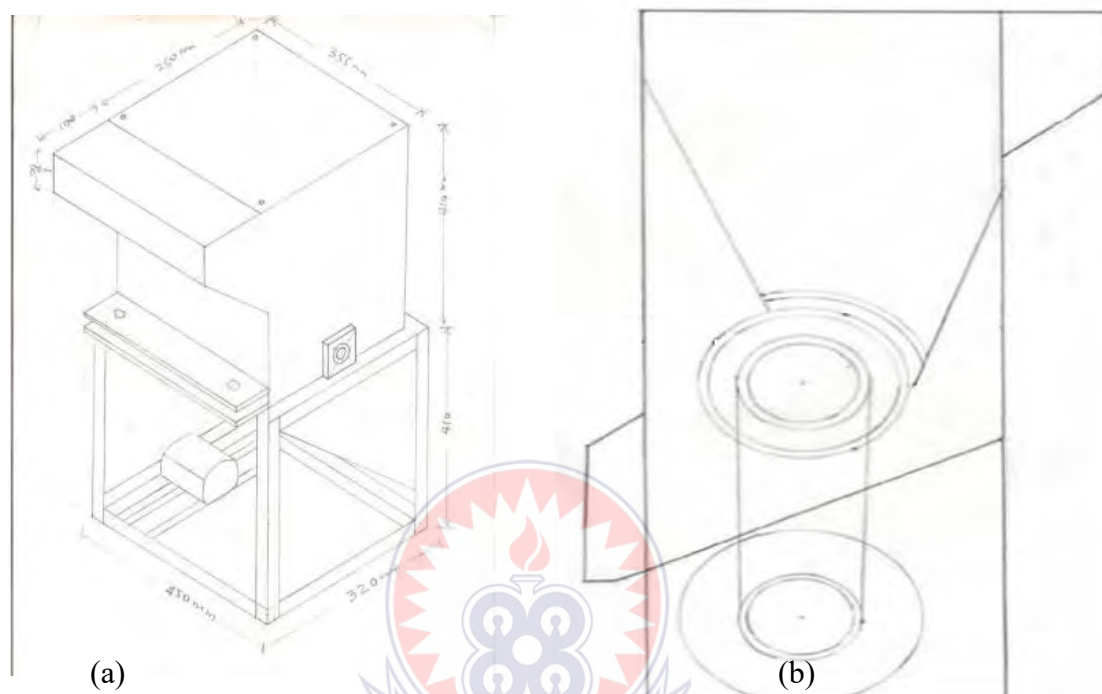

**Figure 7: Isometric drawing of Mobile cassava grater (Aideloje et al., 2018)**

## 2.7 Electricity Powered Cassava Grating Machines

In recent times, electric motors are the preferred prime movers for stationary cassava graters at locations where electricity is available. This is because electric motors are compact, easy to start, and enhance cleaner working environment compared to internal combustion (IC) engines.

Adetunji and Quadri, (2011) designed, fabricated and tested a cassava grater powered by electricity through a single-phase medium speed electric motor. The grater had a stainless-steel grating plate wrapped on the grating drum to improve the hygiene of the cassava mash. It had a grating capacity of 158 kg/h. however the efficiency of the machine was not stated though it is a very important parameter in evaluating machine performance. Figure 6 shows drawings of the improved electricity powered cassava grater.



**Figure 8: Improved cassava grater (a) isometric view (b) front view (Adetunji et al., 2011)**

Dewatering in cassava processing involves applying pressure on the grated pulp to reduce its moisture content. In the dewatering of cassava mash, the particles are constrained while the liquid is free. The pressure applied, varied depth, time, moisture content, volume of material and the particles of material, these are some of the parameters identified by Kolawole et al. (2007). The material moisture content, the mass and the volume were easier to identify. Diop (1998) reported that the Amerindians developed an ingenious press shaped like a long thin basket-weave tube called '*tipiti*'. The operation of the *tipiti*-involved filling it with cassava mashes, hung on a branch of a tree and stretched from the bottom; the reduced volume at the base reduces the mash



volume, water is then squeezed out of the mash. Some other methods involves placing of heavy stone on top of the mash and this was used by Ajibola (1987) when he places heavy stone on cylindrical tank filled with cassava mash to effect dewatering mechanically.

Figure 2.9 to 2.9.4 shows the methods of dewatering cassava dough in the traditional way:

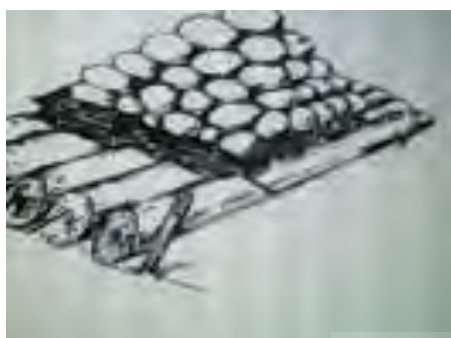

**Figure 9: Heavy stone on top of mash sack**



**Figure9.1 Hanging**



**Figure9.2 Plank**



**Figure9.3 Twisting sack to affect dewatering**

Above figures are reference (Kolawole, Ayodeji and Ogunlowo, 2011)



**Figure 9.4 Single stone dewatering (Kolawole, Ayodeji and Ogunlowo, 2011)**

These old traditional ways of dewatering cassava dough are associated with the following problems:

- ❖ It is time consuming
- ❖ More human effort is require when tightening the stick together
- ❖ The sticks can also break at any time to make the mechanisms ineffective
- ❖ It is also risky when tightening the sticks with rope.
- ❖ It is unhygienic since the sack containing the cassava dough cannot be covered during the processing or during the extraction process.
- ❖ Using the cement blocks as weight makes the extracting process unhygienic.
- ❖ Using the cement block as weight is not safe because it can slip at any time to cause injury
- ❖ It is difficult to use for mass production

These modify design and construction of cassava dough single screw press machine will improve the old traditional ways.

This improvement seeks to address all these problems and therefore makes this project meet the demands of the market and also improve human comfort widely in our humanity.

As far back as 1962, Akindele, observed the need for a mechanical system of dewatering of cassava mesh in the Gari processing method. He observed the need for a neater mechanical way of dewatering Gari pulp to change the unhygienic local method of water removed by compressing mesh sacks with heavy stones and metal objects.

Operation of dewatering is mainly carried out manually under rural conditions. So many methods are in use for cassava mash dewatering which are boulders or logs method,

use of sticks, parallel board method, tree stumps method, chain or string methods and screw jack; Kolawole et al. (2007). Pressing cassava mash have been industrialized with hydraulic presses providing pressures of up to 25 kg/cm<sup>2</sup>; Igbeka et al. (1992). The pressing time can be as short as 15 min with the hydraulic press or as long as 4 days or more when stones are relied upon the only one available to the local processors in some locality. The main reason for dewatering in cassava mash is same in all crops processing to food; it is a pre-drying alternative; Klanarong et al. (1999). Study of centrifugation and direct pressure as means of dewatering was done for cassava starch production by Klanarong et al. (1999). A comparison study of centrifugation and direct pressure as dewatering means was used, while studying the dewatering characteristics of alfalfa protein concentrate; Straub and Bruhn (1978). The result indicated that comparable dewatering could be obtained. Increased acceleration or increased holding time did not give large decreases in final moisture content of the sample.

The improved and available process of cassava mash dewatering could bring about faster rate. They are in the form of a circular press cage holding the fresh pulp or square frame exerting pressure on the sacks. Many types' works by moving a heavy circular or square block, which is lowered or raised by means of, threaded shaft. Some design of press uses hydraulic jack used for cars or Lorries to apply pressure to the mash Igbeka et al. (1992). The frame may consists of two vertical metal posts as shown in Figure 3.0, all require some amount of human effort to operate them, this in turn compressed the mash to cake. Compression of mash into cakes results in the increasing resistance of cakes. Cassava mash cake is compressible and their specific resistance change with the pressure drop across the cake as reported by Kolawole et al. (2012).



**Figure 10: Screw Method (Kolawole, 2011)**



**Figure 11: Jack methods (Diop, 1998).**

## **2.8 Overview of A Press Machine**

Presses are machines used to apply pressure to a product, whether the application is to extract a fluid from a material or to change the shape of a material. Presses used for fluid extraction can be of several different types and are generally used as juice presses. A bladder press has a deflated bladder centered inside a cylinder; when the cylinder is filled with product, the bladder is inflated which presses the product against the cylinder wall. A screw press feeds the product into a wall which extracts the fluid continuously. An example of a press that changes the shape of a material is the tablet press, which forms tablets by applying pressure to a powder in a die. A fly press is the type screw press in which the screw shaft is driven by a flywheel or a pair of fly weights at the ends of a bar. The wheel can either be cranked by hand or driven

by a motor using a friction coupling. The wheel is weighted so its momentum will maintain the motion of the shaft. The screw is considered one of the six mechanical powers, but it is really: Only a modification of the inclined plane. It was used extensively in the early modern period, despite the skill required in making it, in small tools like the GIMLET and CORKSCREW, but also to exert pressure in heavy machinery, for example, in a SCREW PRESS. For this, wood, rather than metal was used in the early part of the period, because it was simpler to work. (Eghareuva, 1990) classified the screw-type press used for dewatering of cassava mesh into those where the mesh sacks are placed on a platform and the top press bar is screwed to compress the mesh sack, and those press that have the mesh sack on a platform which is screwed upward to be compressed by a press bar that is stationary at the top. Machines developed to process fresh tubers include peeling knives and mechanical peelers. The International Institute for Tropical Agriculture (IITA) post-harvest research unit in 1988 developed a knife for peeling cassava root, it is called peeling knife. Tamil Nadu Agricultural University, Coimbatore, India designed several mechanical peelers.

The first type consists of horizontal drum with a central stationary concentric cylinder and auger conveyer. The second type consists of a horizontal roller of diamond mesh fitted on an appropriate structure with suitable bearing for each rotation. The third type, which is preferred as the others caused excessive abrasion and ineffective flow of tuber material is made up of a cylindrical drum with reapers having pintail nails fixed around the inner periphery with no central stationary piece.

## **2.9 Equipment and Material Often Used in Designing the Pressing Machine (Wikipedia.Com, 2013)**

The major materials and equipment used in the fabrication of electric motor driven cassava dewatering press are listed below:

- ❖ The reduction gear box
- ❖ Electric motor
- ❖ Power screw
- ❖ Sprockets and chains
- ❖ Angle irons
- ❖ Beam
- ❖ Bearing
- ❖ Steel plates
- ❖ Electric switch

Eghareuvba (1990), classified the screw-type press used for dewatering of cassava mesh into those where the mesh sacks are placed on a platform and the top press bar is screwed to compress the mesh sack, and those that have the mesh sack on a platform which is screwed upward to be compressed by a press bar that is stationary at the top. IITA (2007), put forward a double screw press which has a loading capacity of 200 to 350 kg applied to five bags per batch of cassava pulp. The rate of dewatering is such that a pulp with initial moisture content of 70-80% is reduced to 40-50% in 4 hours. The motorized double screw compressive traverse cassava pulp dewatering machine has a capacity of 200kg. The pulp was reduced from 80% wetness to 25% in 2 hours. Figure 2.12 shows the cassava pulp dewatering machine.

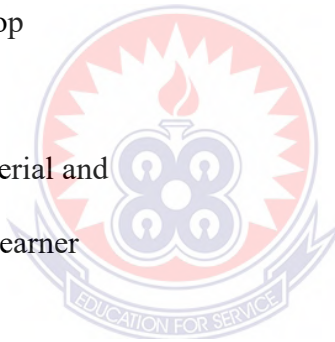

**Figure 12: Cassava Pulp Dewatering Machine. Source: [www.unilorin.edu.ng](http://www.unilorin.edu.ng)**

## **2.10 The Role of Cassava Products**

Cassava performs five main roles

- ❖ Famine reserve crop
- ❖ Rural food staple
- ❖ Industrial raw material and
- ❖ Foreign exchange earner
- ❖ Livestock feed



Despite these roles, the demand for cassava is mainly for food; and opportunities for commercial development remain largely undeveloped.

However, its processing involves a laborer's task.

The objective of the mechanical engineering professions is to bring scientific and technological knowledge into practical use to help society with the provision of basic necessities for human comfort. Hence, cassava dough screw press machine for domestic application came into being to replace the old traditional ways of extracting water/starch from the cassava dough as seen above in. Figure 2.12



## EXISTING CASSAVA DEWATERING MACHINE



**Figure 13: hydraulic press (okike et al., 2015)**



**Figure 14: Single screw press (okike et al., 2015)**





**Figure 15: Double Screw Type (Okike et al., 2015)**

**Figure 13 to 15 shows types of existing cassava pressing machine**

The press and the pressing area should be kept very clean with good drainage system for safe disposal of the effluent to avoid environmental pollution and public health hazards.

**2.11 Literature Summary**

The existing cassava dough single screw press machine has some gaps (the drain tap and the outer mesh for the drain of water and protection of dust and particles entering respectively) to fill to make the machine more presentable and hygienic. For that matter there is a need for construction modification; modification as compare to the existing includes; the use of two cylinders inner perforated and outer cylinder but has drain pipe and tap attached to the outer cylinder for the drain of fluid and outer cylinder prevent house flies and dirt entering and also the inner perforated has a plate perforated at the base to prevent the dough not to seat inside the outer cylinder.

## CHAPTER THREE

### MATERIALS AND METHOD

#### 3.1 Design Consideration

In modifying the existing cassava dough single screw pressing machine, the following considerations are necessary; that

- The machine should be efficient during use in the household as well as movable and safely or easily operated.
- In selecting materials for the construction, adequate care should be taken not to use materials that cannot degrade or corrode easily due to the acidic content in cassava, since cassava produces a large amount of gynogenic glycosides
- The product surfaces should be completely free from crevice which can harbor bacteria.

#### 3.2 Two Conceptual Designs

The design process started with the conceptual design stage where a set of specifications were clearly defined and analyzed in order to come up with the general contour, size and performance of the cassava dough single screw pressing machine. Based on the review of the various existing designs, analyzes, evaluation and conceptualization were done on the two designs using design matrix.

### 3.2.1 Conceptual Design One

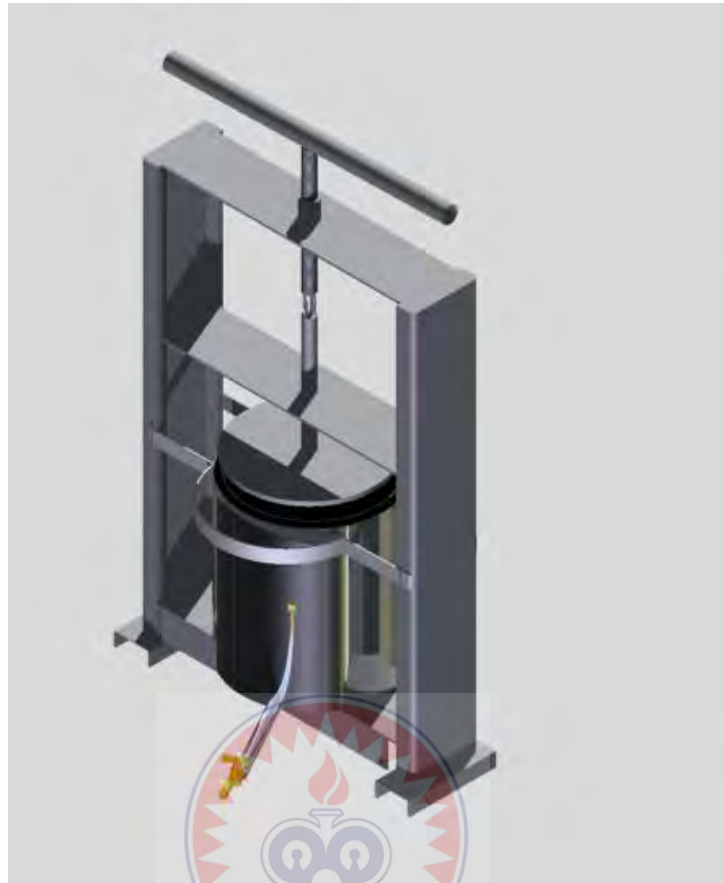

**Figure 16: Conceptual Design One (1)**

The detailed drawing and parts can be seen in appendix

### 3.2.1.1 Exploded View for Design One

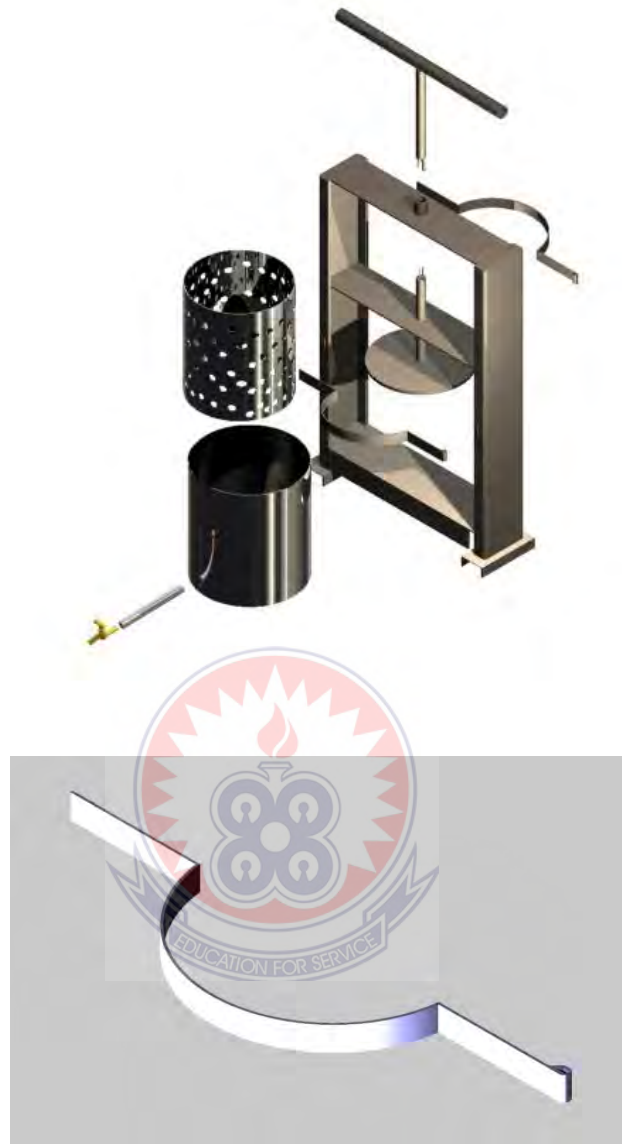

**Figure 17: Conceptual Design One - Exploded View**

**Table 1: Parts of The Object**

A	Screw Handle
B	Bolts
C	U – Yoke
D	Screw Thread
E	Frame
F	Lid (Pressure Plate)
G	Inner Perforated Cylinder
H	Outer Cylinder
J	Stand
K	Tap
L	Drain Pipe

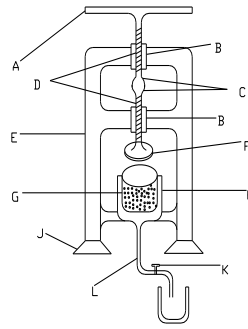

The design above shows a complete assembly of a cassava screw press object. Components of the design include u-iron and angle iron frame, two-inch mild steel square thread, u-yoke, lid (pressure plate), inner perforated and outer cylinders, two inch drainage pipe and tap, and storage tank for the fluid.

### 3.2.2 Conceptual Design Two

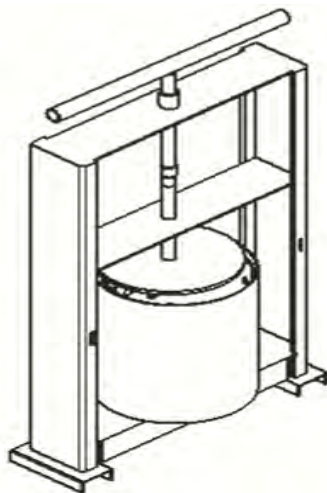

**Figure 18: Conceptual Design Two (2)**

**Table 2: Comparison of Conceptual Designs**

First Design	Second Design
Uses two cylinders, inner perforated and outer cylinder but has drain pipe and tap attached to the outer cylinder	Uses two cylinders, inner perforated and outer cylinder only
Uses u-yoke in between the screw thread	Uses bevel gear in between the screw thread
The inner perforated has a plate perforated at the base to prevent the dough not to seat inside the outer cylinder which some of the drain fluid will remain at the base of the outer cylinder	Has no base plate

**Table 3: Parts of the object**

A	Screw Handle
B	Bolts
C	Gears
D	Screw Thread
E	Frame
F	Lid (Pressure Plate)
G	Inner Perforated Cylinder
H	Outer Cylinder
J	Stand

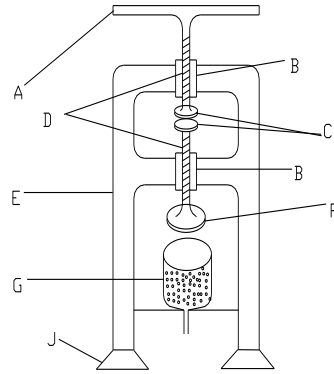

The second conceptual design which consists of u-iron and angle iron frame, two inch mild steel square thread, lid (pressure plate), inner perforated and outer cylinders.

Above are two possible solutions made and the first one is selected to develop for a final project.

Conceptual design one was selected base on hygienic conditions

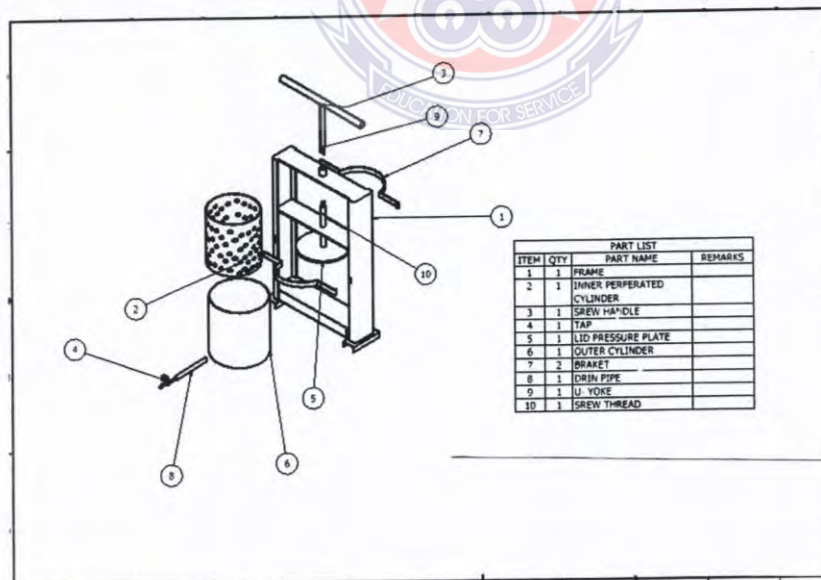

### 3.3 Annotated Design for Cassava Dough Single Screw Press

The reasons for choosing this are that it is safe and protective for use due to additional outer mesh that prevents dirt from entering into the inner perforated units. The unit is very simple and will not be difficult to construct in the workshop. It has a round stand to support the main unit. The outer cylinder collects the water. The outer cylinder which allows the water to be drained when required. This unit or object would be very easy to handle by the user. The user can be 6 years and above. It has attractive texture and could be used in any environment. It also modifies the existing cassava dough single screw press machine. It would be able to serve its purpose and work hygienically, it is hand operated and the unit can be dismantled and assembled.

### 3.4 Materials Selection Used in the Construction

Look at the various properties of materials helped me to select appropriate materials for the object.

**Table 4: Materials Used for the Construction**

S/No.	Components	Materials Used
1	Inner perforated mesh Cylinder	Stainless Steel
2	Outer Cylinder	Stainless Steel
3	Screw Handle	Mild Steel
4	Lid	Mild Steel
5	Frame	Galvanize U- channel
6	Screw Thread	Mild Steel
7	Bevel Gear	
8	Tap	



### 3.4.1 Description of Machine Parts

The machine is expected to have the following components

**The Main Frame:** The main frame will be constructed with U and angle iron. They are welded together to form the frame work. The welding provides very rigid joints. This is in line with the modern trend of providing rigid frames. This provides the strength and rigidity for the overall machine.

**Inner Perforated Mesh Cylinder:** It should be constructed with stainless steel

**Outer Cylinder:** It should be constructed with stainless steel

**Screw Thread:** It should be constructed with mild steel

**Screw Handle:** It should be constructed with mild steel

**Lid:** It should be constructed with mild steel

**Gear:** It should be off bevel



### 3.5 Design Process

Making of cassava squeezer would be achieved through a process. It is a process through which one passes to come out with an object of a unit.

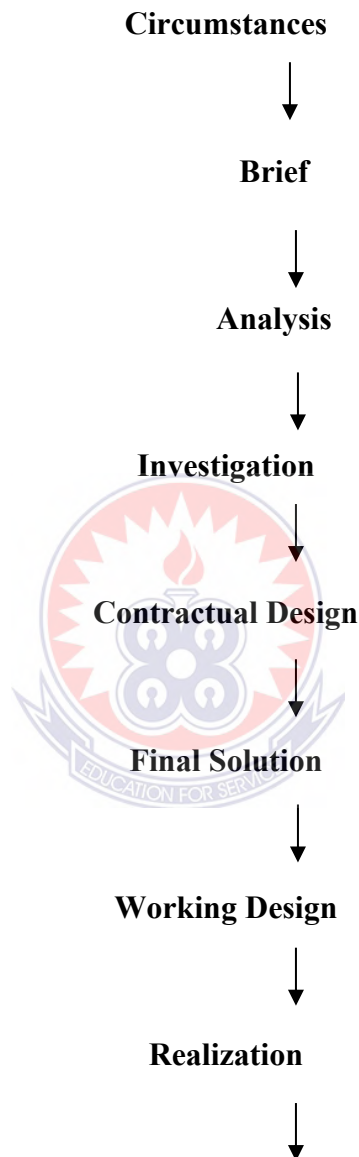

### Testing and Evaluation

#### 3.5.1 Circumstances

Circumstance is the problem or the needs that have been seen or identified, most of the workers find it very difficult to extract water from the cassava dough and as a result, most of the water remains in the cassava dough. Cassava processing into Gari using

traditional method is tasking, ineffective, time-consuming and also inefficient. Such difficulties arise in the draining of the water from the cassava dough since the conventional method available involves processes that require a lot of labor and man hours. The situation or the problem is worsening when the quantities to be produced are very large.

### **3.5.2 Brief**

A brief is a short statement that describes or expresses what would be designed to solve a problem. This brief starts with the word “Design and is followed by either, construct, make, manufacture, prepare, produce, fabricate, realize. For example design and construct a simple cassava dough screw pressing machine.

### **3.5.3 Analysis**

In the analysis, the purpose of the object, the materials to be used, the one to use the object or the machine, the appearance of the object, the construction, and the finish and the economical factors are all considered. This is also where the analysis questions are asked about the object to be constructed. The scope of the analysis questions are:

- Function
- Material
- Ergonomic
- Aesthetic
- Economic
- Construction
- Safety
- Finish

### **3.5.4 Investigation**

This is where answers about analysis questions are produced through a study of materials and sources in order to reach a conclusion about how the object should be.

### **3.5.5 Specification**

Specifications are the statements that point out the necessary requirement of the object.

In other words, it specifies decision taken. It also answers analysis questions. Examples of specification are as follows:

#### **3.5.5.1 The Function**

The function deals with the purpose of the object. Examples of analysis question on function are:

- What will be the main function of the object?
- How will it function?
- What other function can the object perform?
- How many quantities of cassava dough will it take?

Answers to the likely questions to the function of the object are:

- The object should be used to extract water from cassava dough
- By putting the dough in the chamber and operate the linkages
- It could be used also to extract oil from pounded palm fruit
- The object can be destroyed by corrosion and over torque loading
- It can load 20 to 25kg of cassava dough.

#### **3.5.5.2 Material**

Material deals with the type of things that are appropriate and available which can be used to construct the object. Example of analysis question on material

- What will be the main material to be used?
- What other material can be used?

- Which material is available?
- What properties should the material possess?

Answers to the likely questions to the material of the object are:

- The main material to use is stainless steel
- The other material to be used are brass and tin
- Available materials are steel, brass and tin
- Steel is durable, elastic and malleable

### **3.5.5.3 Ergonomic**

This deals with the size of the object in relation to human used. Analysis questions on ergonomic.

- Who will use the object?
- How many people will use the object?
- What must be the weight of the object?
- What is the age of the user?
- What is the size and height of the user?

Answers to the likely questions to the ergonomic of the object are:

- Gari factory (home-use and small scale) workers would use the object
- One person will use the object
- The weight is 35kg
- Between 7 years and above
- Between 4 ft to 6<sup>1</sup>/<sub>2</sub>ft

### **3.5.5.4 Aesthetics**

This deals with how the object beautifies the environment

- How will it be made to beautify the environment?
- How will the appearance be like?

Answers to the likely questions to the Aesthetic of the object are:

- By springing, tumbling or painting with attractive paint or tin
- The appearance should be very fine or smooth

### 3.5.5.5 Cost

This is concerned with the cost and time involve in making the object. Analysis question on economic are

- How much will it cost to make/prepare the object?
- How long will it take to make the object
- What will be the labour cost of the object (workmanship cost)

Answers to the likely questions to the economics of the object are:

- The unit cost would be affordable
- The unit would be completed in a limited interval
- The workmanship will be between 15% – 25% of the total cost of the object.

## 3.6 Methodology

### 3.6.1 Machineries and Machining Processes Used In The Fabrication Processes

**Drilling machine:** This can be hand drilling or pillar drilling Machine. This machinery was used for most drilling jobs. The work is stationery while the spindle carrying the drill chuck and bit that moves the work must be held with a vice during drilling.

**Lathe:** This was used for an extensive array of precision works also, such as boring, turning, facing of the assembly parts.

**Hand grinding\ cutting disc machine:** This is hand held and it comes in two sizes. The disc comes in the sizes 9", 7" or 4" diameters. The 7" disc was used for cutting and grinding.

**Welding Machine:** It is used in conjunction with electrode and tong for joining two or more metals together. It was used with mild steel electrode when welding the mild steel.

Welding can either be tacking (which can be easily broken) during setting, stitching, (which can be used to hold thin metals (1 mm metal sheets together firmly) or running (which is used for thick metal plates, 3mm). The mild steel electrode of gauge twelve (2.5mm diameter) was used. Welding glasses (dark) was used when working.

**Bending machine:** it is used for bending sheet metals up to 5mm thick at different desired angles and shape.

**Table shear:** It is big and heavy. It was used for cutting plate less than the 3mm and 4mmsheet, and it gives a straight cut edge unlike the hand cutting disc.

### 3.6.2 Other Tools Used for The Fabrication of The Object

**Try Squares:** It is used for setting and checking perpendicular alignments of work piece.

**Plumb/Spirit Level:** It is used for checking the alignment of work pieces to ensure balance which reduces vibrations.

**Dividers:** It is used for marking out circles or circular distances to be cut using hand cutting disc. **Venire Caliper Steel rules and Tape:** It is used for measuring dimensions for marking out on the work piece. Tape was used for longer dimensions.

**Scriber and Marking chalk:** It is used for making the markings on metal visible. It is immune to water and dirt.

**Center punch:** It is used for marking the point to be drilled or for placement of a divider.

**Drill bits:** It comes in various sizes in mm. They are used for drilling. The drill bits used were 6mm, 10.5mm, and 16mm.

**Mallet:** Used for beating sheet metal into desired shapes. It prevented denting of the perforated stainless sheet.

**Spanners (flat, ring, adjustable), Ratchet & socket:** Used for tightening and losing bolts or nuts. The sizes used were M6, M10, and M16.

**Files (square, round):** They were used to tarnish sharp edges to ensure smoothness and prevent injuries

**Painting Compressor, Engine, Cup, Brush, and Sandpaper:** These were used in painting. The sand paper is used to remove the dirt, carbon, and previous paint.

### 3.6.3 Safety Gears and Safety Precautions

These are the gadgets used or present in the factory which helps prevent accidents, injuries, loss of life and property.

**Hand gloves:** These are generally made of different materials. The one worn depends on nature of job to be done. Perfect fit sizes are always worn.

**NOTE:** Warnings not to use gloves when using the pillar drilling machine as it has been known to dislocate arms from the shoulder joint.

**Eye protector:** These are glasses which come in different shapes. A black lens glasses for welding to prevent ultra violet light damage to the eye cells. A clear-lenses glass is used for cutting and grinding.

**Safety Boots and Wear:** The right size of boot and overall, for the fabrication was worn at all times.

### 3.6.4 Safety Precautions

When using welding machines, the earthen (negative terminal) must not be in contact with someone/ other metals causing electric shock.

The overall is not too big, to prevent accidents. It must not get caught up in any machinery because it can lead to injuries.



Gloves are not used during drilling because while clearing metal scraps, the glove might get caught up in the working bit and lead to shoulder dislocation.

When using the lathe, tighten the work piece on the chuck well to prevent flying work pieces.

Also use safe speeds for different types of materials to prevent accident.

### 3.6.5 Machining Operations

- **Marking and Cutting:** This operation encompasses the using of Scriber in marking and hand cutting disc in cutting out the marked parts.

- **Joining:** Full welding was used to join the frames and some other parts while bolts and nuts are used for others. When bolts and nuts are used, the bolts are usually welded permanently in place for nut to be used in order to ensure the ease of maintenance.

**Welding Process:** This is the method by which the sheet metals are joined together. The welding method was stitching because of the lightness of the plate.

### 3.7 Construction

This deals with how the object will be constructed and the necessary tools needed to construct the object. Analysis question on construction are:

- What tools would be needed?
- What type of joints should be used?

Answers to the likely questions to the construction of the object are:

1. Tools needed to construct the unit are:
  - Hacksaw, file, drilling, machine, chisels all type of cutting or sawing tools used in mechanical workshop
  - Emery cloth and sand paper or glass paper
  - Spraying machine

- Hammer
  - Straight edge
  - Scriber
  - Surface plate
  - Welding machine
  - Try square
2. Lap joint
  3. The unit or the object should be constructed in the mechanical workshop
  4. Sharp edges, (burrs) must be removed

### **3.8 Safety**

It deals with how safe the object will be when using. Analysis questions on safety are:

- Is the object safe for the user?
- Is the material chosen for the object healthy or safe?
- Is there any need for environmental safety consideration?
- What steps would be taken to ensure safety of the object?

Answers to the likely questions to the safety of the object are:

- The object should be safe to the user when handling it.
- The material used for making the unit is very healthful
- It is very safe in the environmental
- Warning instructions would be written on it.

### **3.9 Finish**

This talks about the final appearance of the object. Analysis questions on finish are as follows:

- What process will be involved in the finishing?

- Is the finisher protective to the surface of object?

Answers to the likely questions to the finish of the object are:

- The finisher is very protective
- Dipping

### **3.10 Operational Sequence for the Two Designs**

This device can be carried to any place for use

The grated cassava dough should be firstly put in a nylon sack for easily pressing and packaged.

- Turn the pressing handle anticlockwise to lift up the inner cylinder cover (lid).
- Put the cassava dough in the nylon sack inside the opening cylinder
- Turn the pressing handle clockwise to move downwards to compress the cassava down.
- The water will automatically find its way into the bottom of outer cylinder
- Turn the pressing handle anticlockwise again to lift up the top or inner cylinder
- Remove the squeezed cassava dough from the inner cylinder
- Clean the machine with water and with oil where necessary.

The operational sequence are the same for both design just that the conceptual design one (1) adopt the use of gears to ensure that less effort is being applied on the handle during turning.

## CHAPTER FOUR

### DESIGN CALCULATIONS

#### 4.1 The Volume and The Surface Area of Inner Perforated Cylinder

##### Data

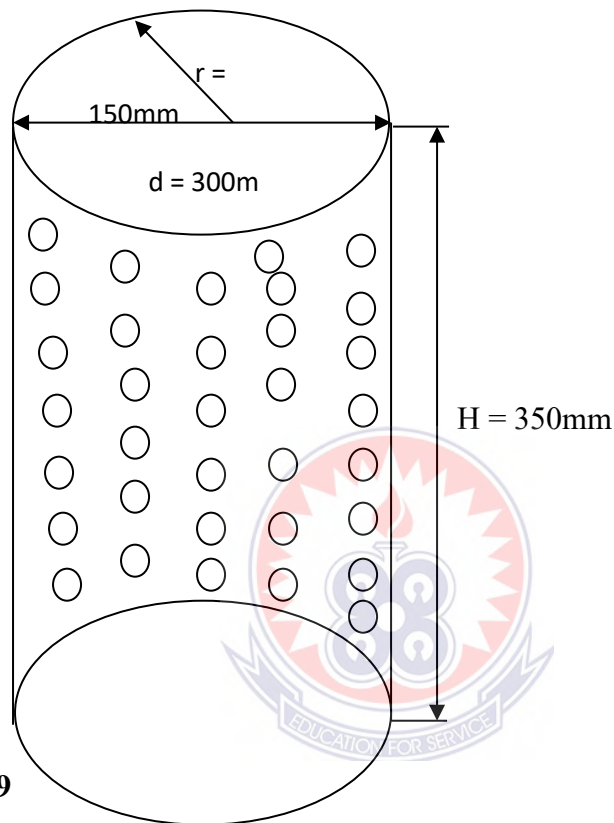

**Figure 19**

All measurement are converted into meters (m)

$$\text{Diameter (d)} = 300/1000 = \underline{0.3\text{m}}$$

$$\text{Radius (r)} = 150/1000 = \underline{0.15\text{m}}$$

$$\text{Height (h)} = 350/1000 = \underline{0.35\text{m}}$$

##### Solution

**The volume (v) of the inner perforated cylinder is given by:**

$$\text{Volume (v)} = \pi r^2 h$$

Where; r= radius of the cylinder

h = height of the cylinder

Therefore; volume (v) =  $\pi r^2 h$

$$v = \pi \times 0.15^2 \times 0.35$$

$$\text{Volume (v)} = \underline{0.024\text{m}^3}$$

**The surface Area of the inner perforated cylinder is given by:**

$$\text{Surface Area} = (\pi \times d \times h) + 2(\pi \times r^2)$$

Where; d = diameter of the cylinder

h = height of the cylinder

r = radius of the cylinder

$$\text{Therefore; surface Area} = (\pi \times 0.3 \times 0.35) + 2(\pi \times 0.15^2)$$

$$\text{Surface Area} = 0.329 + 0.141$$

$$\text{Surface Area} = \underline{0.47\text{m}^2}$$

#### 4.2 The Volume and The Surface Area of an Outer Cylinder

##### Data

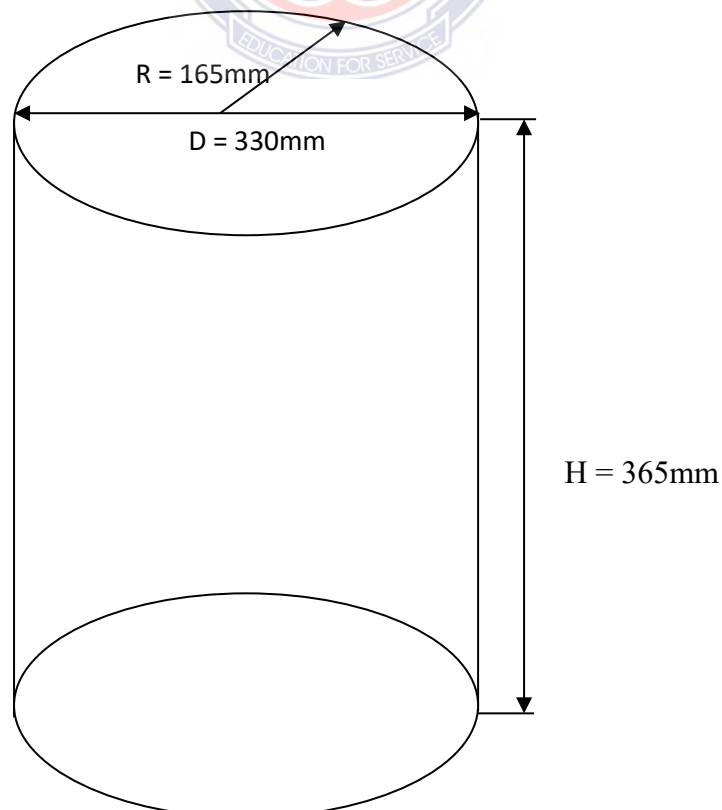

**Figure 20**

$$\text{Diameter (d)} = 330/1000 = \underline{0.33\text{m}}$$

$$\text{Radius (r)} = 165/1000 = \underline{0.165\text{m}}$$

$$\text{Height (h)} = 365/1000 = \underline{0.365\text{m}}$$

### **Solution**

**The volume (v) of the outer cylinder is given by:**

$$\text{Volume (v)} = \pi r^2 h$$

Where; r= radius of the cylinder

h = height of the cylinder

Therefore; volume (v) =  $\pi r^2 h$

$$v = \pi \times 0.165^2 \times 0.365$$

$$\text{Volume (v)} = \underline{0.031\text{m}^3}$$

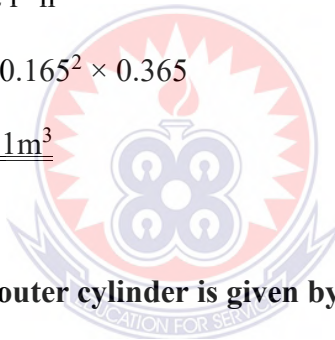

**The surface Area of the outer cylinder is given by:**

$$\text{Surface Area} = (\pi \times d \times h) + 2(\pi \times r^2)$$

Where; d = diameter of the cylinder

h = height of the cylinder

r= radius of the cylinder

$$\text{Therefore; surface Area} = (\pi \times 0.33 \times 0.365) + 2(\pi \times 0.165^2)$$

$$\text{Surface Area} = 0.378 + 0.171$$

$$\text{Surface Area} = \underline{0.549\text{m}^2}$$

### 4.3 Production Cost Analysis

**Table 5: Job Cost for Construction of Cassava Dough Single Screw Pressing**

<b>Machine</b>					
<b>S/N</b>	<b>QUANTITY</b>	<b>MATERIALS</b>	<b>UNIT PRICE</b>	<b>TOTAL AMOUNT</b>	
			<b>GHC</b>	<b>GHC</b>	
1	1/4 length	4" × 2" Galvanize U-channel	120.00	120.00	
2	¼	2mm Stainless Steel Plate	100.00	100.00	
3	1pair	Bevel Gear	30.00	30.00	
4	2pcs	Square Thread Shaft and Nut	50.00	100.00	
5	1pc	10mm Lid (Pressure Plate)	20.00	20.00	
6	½ packet	Electrode	9.00	9.00	
7	2pcs	Cutting Disc	8.00	16.00	
8	15pcs	Stainless Steel Electrode	1.00	15.00	
9	½ gallon	Paint (Blue)	20.00	20.00	
10	½ gallon	Petrol	5.00	5.00	
11	2feet	½" Stainless Steel Pipe	15.00	15.00	
12	1pc	½" Tap	15.00	15.00	
<b>Total Cost of Material</b>				<b>465.00</b>	
<b>Contingency 10%</b>				<b>46.50</b>	
<b>Labour Charge</b>				<b>100.00</b>	
<b>Transportation</b>				<b>50.00</b>	
<b>Grand Total</b>				<b><u>GHC 661.50</u></b>	

## 4.4 Precautions and Maintenance

### 4.4.1 Precautions

- The object should be properly positioned
- Place the object in a dry place; avoid rusting
- Do not over tighten the pressing handle
- Children under 6 years should not allowed to operate the object
- Do not over load the object
- Take proper care when transporting the object from one place to another

### 4.4.2 Maintenance

- Wash the object after use
- Check the object operational work or condition every time of using.
- Inspect, and weld or re-tighten any loss joint

**Table 6 Design/Layout**

Cassava variety	Number of sample	Container shape	Dewatering method
IITA TMS 4(2) 1425	C9 C12 C15	Cylindrical	Rope/Stick
	C9 C12 C15	Square	
	C9 C12 C15	Sack	
IITA TMS 4(2) 1425	C9 C12 C15	Cylindrical	Hydraulic
	C9 C12 C15	Square	
	C9 C12 C15	Sack	
IITA TMS 4(2) 1425	C9 C12 C15	Cylindrical	Screw
	C9 C12 C15	Square	
	C9 C12 C15	Sack	



#### **4.5 Method of Testing and Results**

Dewatering was affected using two tanks made of 1 mm galvanized steel plate. The tanks were drilled at the base with 7 mm diameter drill to provide passages for the fluid flowing from the mash. Grated cassava mashes in sacks, in the square and cylindrical containers were tested with single screw press, hydraulic jack press and rope / stick methods. The procedure involves each of cassava-grated samples dewatered with the mash carefully and measured at 10 kg into well-labeled sacks. The purpose of putting the mash in a sack was to provide filtration at all sides at the same standard, since the sacks can be moved out of the containers easily. The best method was discovered from the most efficient, the best to meet set moisture content required at a given time for gari production.

#### **MATERIAL MASS AND HEIGHT MEASUREMENT**

The heights of samples were measured using steel rule before dewatering and after the experiment. Mass of samples was also obtained by weighing the container and sample before and after the experiment.

#### **APPLIED PRESSURE**

The pressure applied was read from the gauge in the experimental equipment. The samples in the dewatering tank placed on the equipment with the pressure applied using a hydraulic jack, screw and rope/sticks methods at different time. The observed pressure reading from the attached pressure gauge was recorded table 6

### **TIME/VOLUME OF LIQUID**

The measurement of time was done using a stopwatch. The starting time noted with the volume of expressed liquid. The pressure was kept constraint at the pick, for every 30 s as the liquid gradually a drop in flow rate the change in volume is always noted. The cumulative filtrate volume and time presented in data sheet.

### **MOISTURE CONTENT OF SAMPLES**

The moisture content of the cassava mash samples was noted before and after the experiments. The moisture content of samples was obtained by drying the samples in an oven at 100°C until no further change in weight occurred. This took three days of 70 – 72 h in a try-temp hot pack oven and weighing took place daily.

### **CASSAVA MASH RESISTANCE**

Mash resistance was noted as internal resistance developed as opposed to applied pressure, only determined with calculation from the data obtained when a constant pressure operation was carried out on the samples.

### **EFFECT OF APPLIED PRESSURE**

Samples tested from screw, hydraulic jack press and rope/stick methods, the result obtained using the cylindrical container with the hydraulic jack press reduce the moisture content of mash to the acceptable level for gari production at a pressure of 69000 N/m<sup>2</sup> while the method of rope/sticks gave the poorest result in the experiment carried out, the required moisture content for gari production process was expected to be 40 to 45% mcwb. Obtained result from the rope/stick and sack method at 20700

N/m<sup>2</sup> was 58.7% mcwb. Advancing beyond this pressure point was difficult. Using hydraulic jack at 48300 N/m<sup>2</sup>, 44% moisture content was obtained

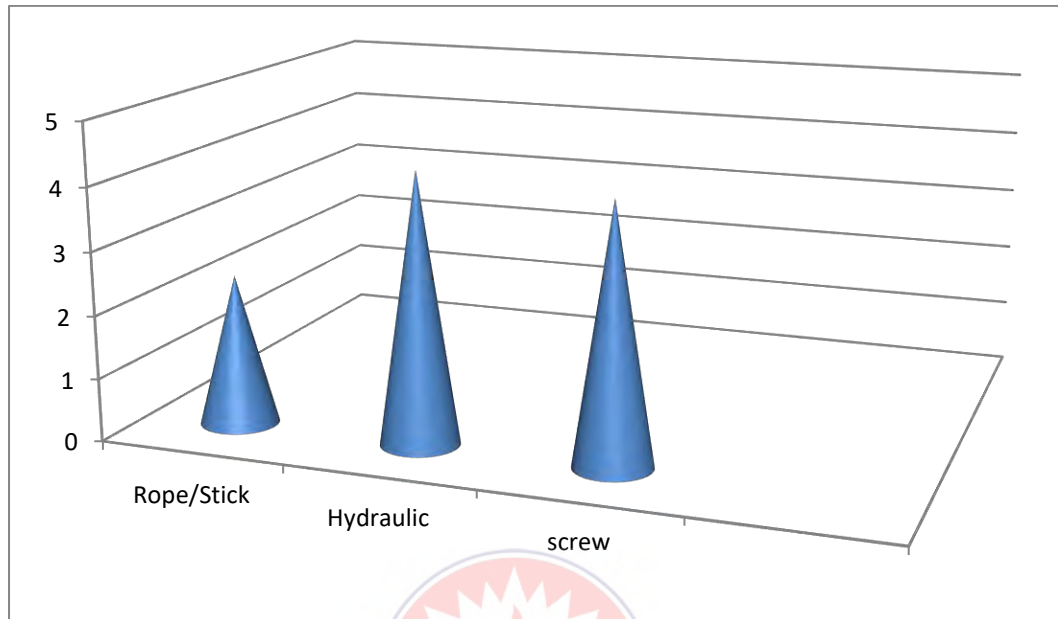

## CONCLUSION

The results obtained show that not much pressure can be sustained by stick/rope method, as more time will be required. The screw and the hydraulic methods are very efficient. The hydraulic jack method of dewatering shows clear efficiency with the C12 sample as shown in Figures 4, 5 and 6, but no significant differences were noticed between the screw jack method and hydraulic methods when used on C9 and C15 samples. This confirms Igbeka et al. (1982) statement that screw presses and jack presses are used for greater efficiency and speed.

## CHAPTER FIVE

### SUMMARY, CONCLUSION AND RECOMMENDATION

#### 5.1 Summary

The new method of extracting juice from cassava dough for gari processing is done by the use of cassava dough single screw pressed machine. The concept of this was first introduced to Asia in the 17<sup>th</sup> century and to Africa in about 1558 said by Quadri A.H (2010). However, despite the importance of this technology a number of deficiencies could be found using the machine.

This dissertation is focused on modification and construction of the existing cassava dough screw pressing machine which would be useful for home-use, retailers and small-scale farmers and also to promote healthy consumption of cassava products.

Some design considerations used in this dissertation include; the efficiency of the machine during usage in the household; the (portability) of the machine among others. Another problem considered in this construction was the fact that cassava produces a large amount of cyanogenic glycosides, so in selecting materials for construction, adequate care was taken not to use materials that cannot degrade/ corrode easily due to the acidic content in cassava.

The volume and the surface area of the perforated cylinders were  $0.024\text{m}^3$  and  $0.47\text{m}^2$  respectively. Also, the outer cylinder has a volume and surface area of  $0.031\text{m}^3$  and  $0.549\text{m}^2$  respectively. The inner cylinder has been modified with the use of stainless steel whereas the outer cylinder and bevel gears used are the new invention made. The object or machine runs by man power.

It is recommended that the efficiency and the speed at which the machine operate can further be improved. This could be done with weight reduction and the reduction of vibration

## 5.2 Conclusion

The home use/small scale cassava dough screw press machine was designed, fabricated and tested. It was found to be effective and efficient and could press about 98% juice from the dough.

This machine can be used at home-scale for domestic applications and it is affordable since the cost of production is low about **GH¢ 661.50** which will reduce during large scale production.

Based on the construction materials selection and quality of fabrication work, the machine is durable and expected to last more than 10 years.

## 5.3 Recommendations

The following are recommended:

- the machine should be produced on large scale for small-scaled use  
(Commercialization)
- the efficiency, design mechanism (in terms of pressing unit), and speed at which the machine operates can be improved upon in the future. The above can be done hand in hand with weight reduction while maintaining balance and reducing machine vibrations.

## REFERENCES

- Akinrele (1962). “*Manufacture of Gari from cassava in Nigeria*” First International Congress on Food Technology London.
- Eghareuva O. M. (1990). “*Design and Construction of Cassava pressing Machine*” Project report.
- IITA Food Net, (2007). “*Double Screw Press*” Agro-enterprises manual processing equipment, Post-Harvest Engineering Unit, IITA, Ibadan, 1-5.
- Aideloje, V. E., Okwudibe, H. A., Jimoh, A. Z., & Olawepo, B. B. (2018). Development and Utilization of Mobile Cassava Grating Machines in Nigeria. *Journal of Environmental Issues and Agriculture in Developing Countries*, 10(3), 168–180.
- Apodi, J., Akidiweasagadunga, P., & Kwablaamedorme, S. (2018). Design and Construction of a Manually Operated Cassava Grating Machine for the Post Harvest Unit of the Department of Agricultural Engineering of Bolgatanga Polytechnic. *International Journal of Advanced Research in Science, Engineering and Technology*, 5(10), 7091–7098. Retrieved from [www.ijarset.com](http://www.ijarset.com)
- Nuer, A. T. K. (2010). *Sustaining Rural Technology Transfer Under Rural Enterprises Projects (a Case Study of Cassava Processing Technologies in Rural Ghana)*.
- Opanдох, D. (2015). *Standardisation of the grating surface of cassava graters for gari*.
- Kolawole, P. O., Agbetoye, L., & Ogunlowo, S. A. (2010). Sustaining world food security with improved cassava processing technology: The Nigeria experience. *Sustainability*, 2(12), 3681–3694. <https://doi.org/10.3390/su2123681>

## APPENDIX

### DESIGN DETAIL DRAWINGS

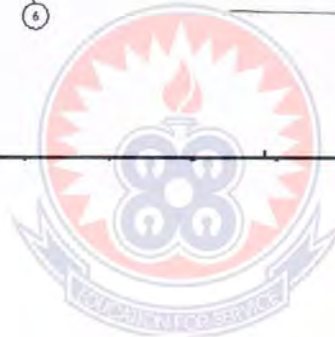
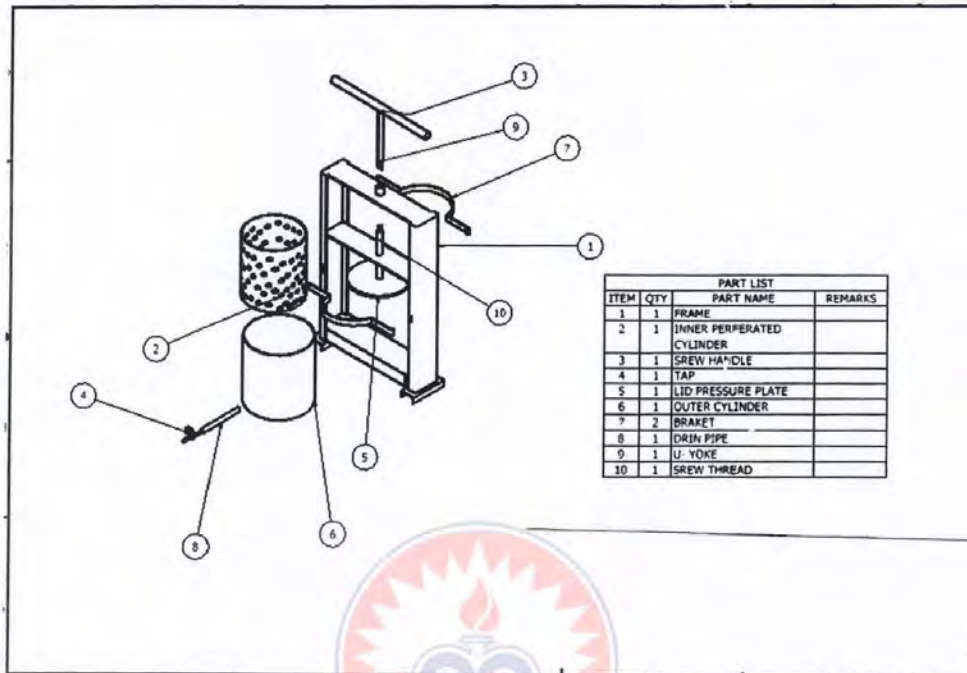

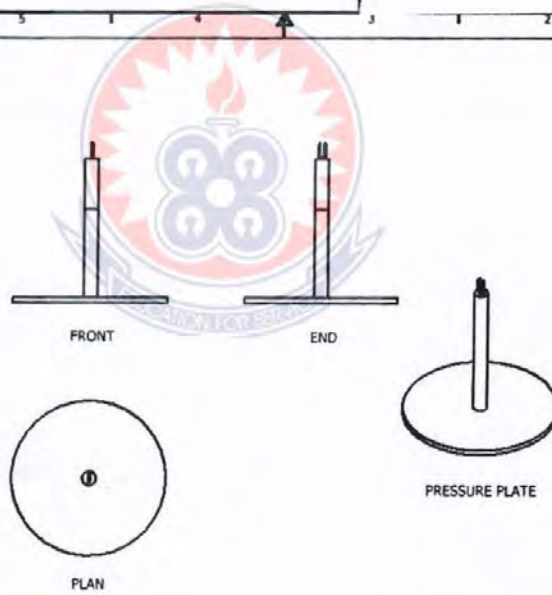
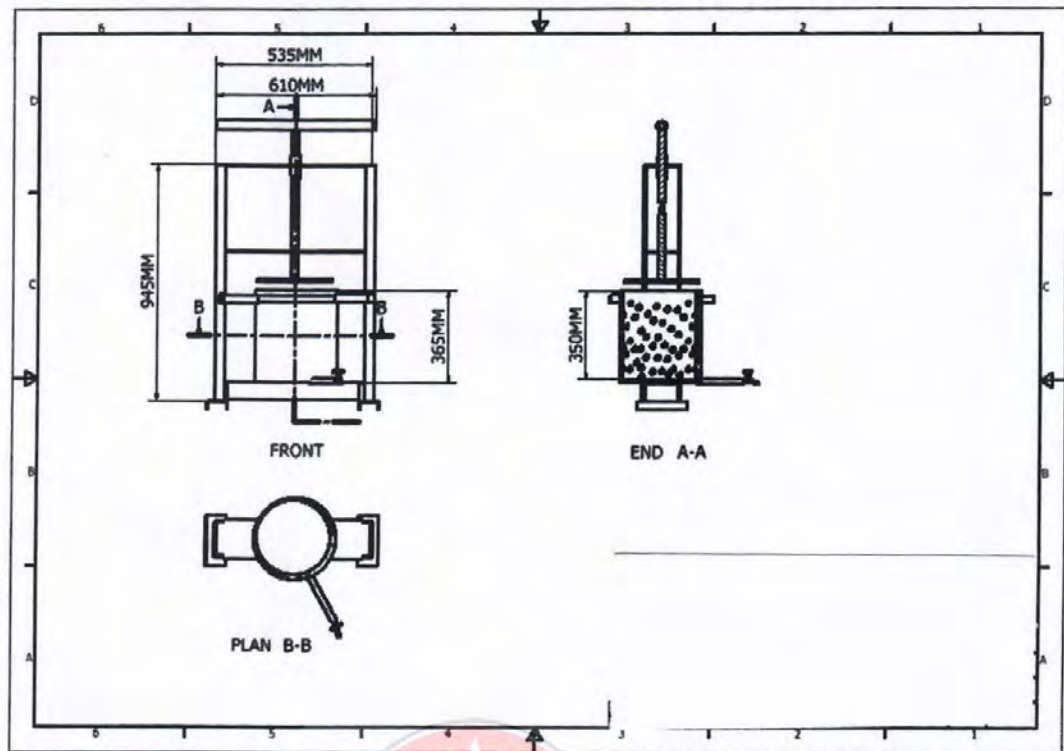



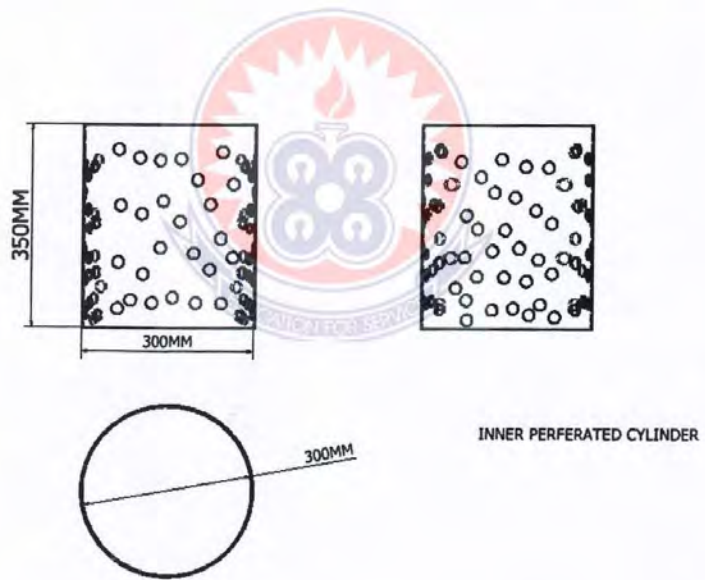
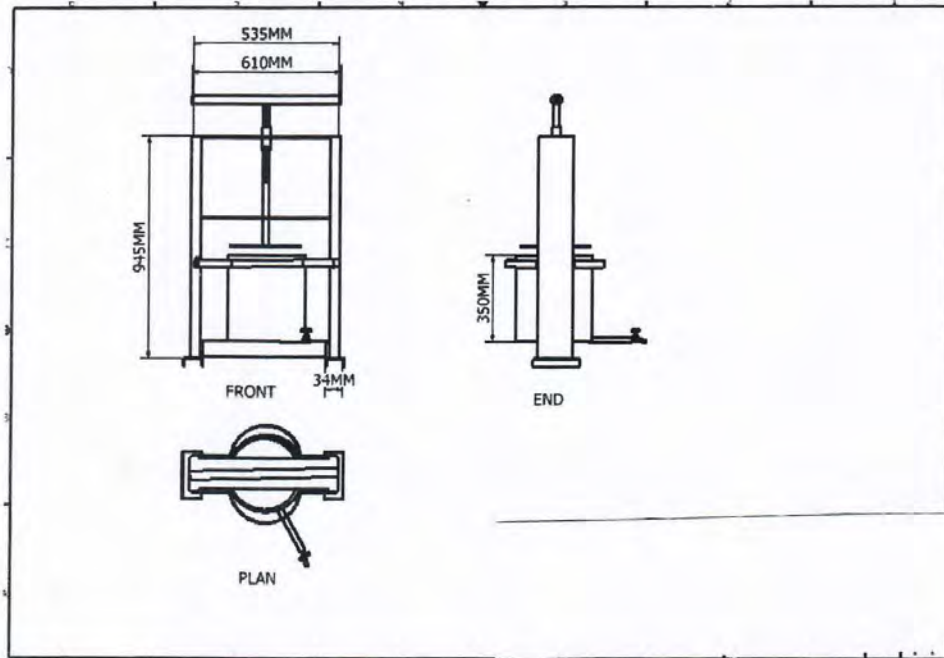

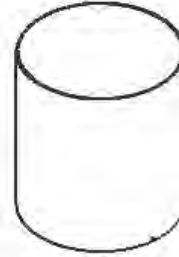
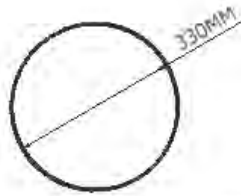
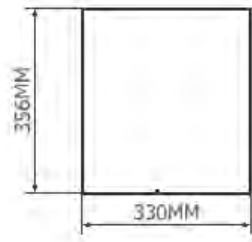

OUTER CYLINDER



